

ProChipper®

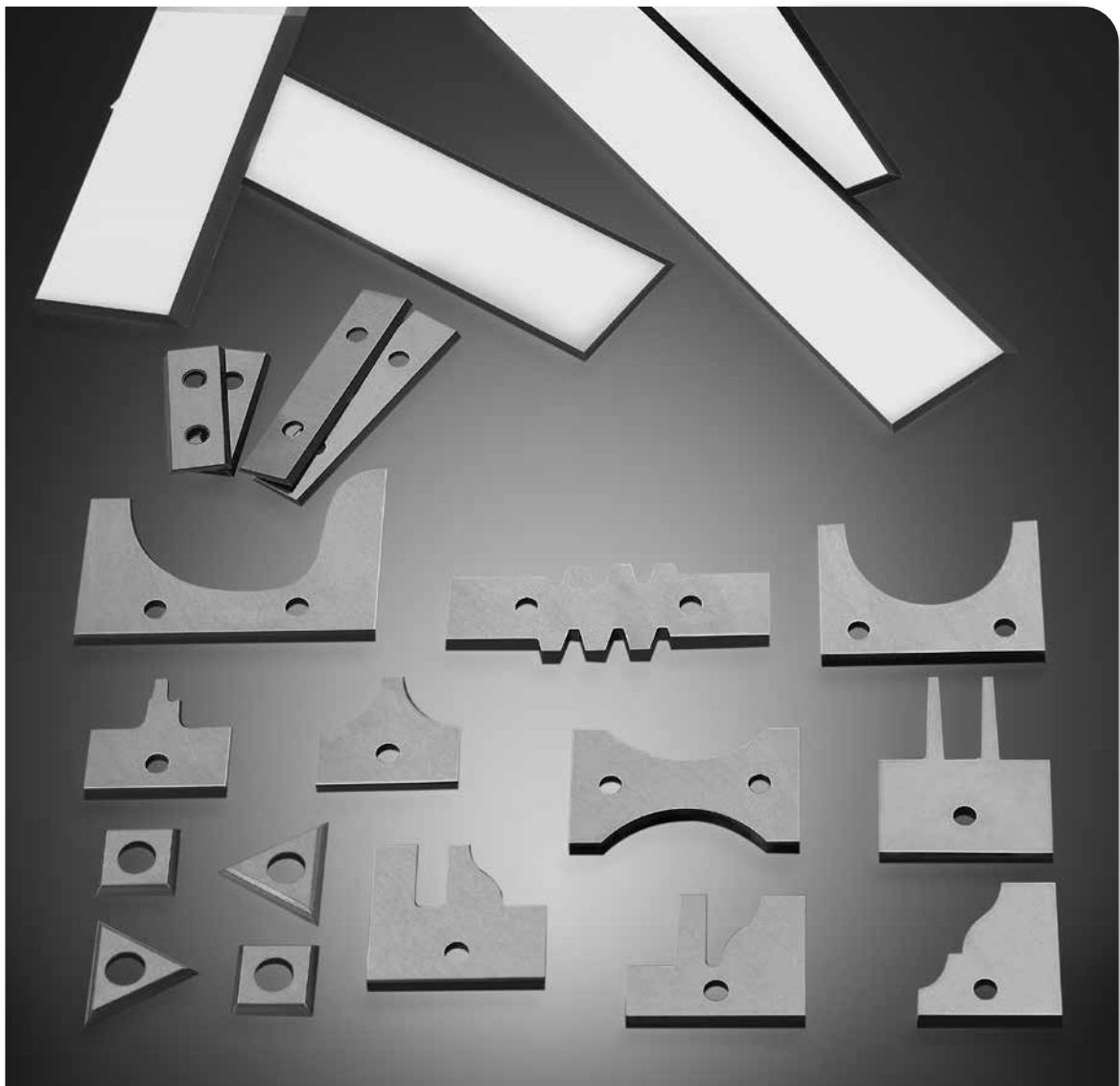

tooling systems



Messer, Ersatzteile und Hilfsmittel
Knives, spare parts and toolinh accessories

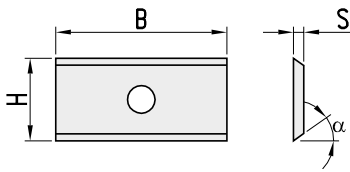

- HF21:** Für Weichholz
For Softwood
- HF10:** Standardqualität
For wood
- HF01:** Für MDF und abrasive Werkstoffe
For abrasive materials (chipboard/MDF)
- FMG02:** Für MDF und HDF
For MDF and HDF
- KCR08:** Für erhöhte Standzeiten
For longer endurance
Auf Anfrage - *On request*

Ausführung 1: 2 Schneidkanten, 1 Loch
Type 1: 2 cutting edges, 1 hole
HW

B	H	S	α	Körnung/Grain	Art. Nr.
$\alpha = 35^\circ$					
7,5	12	1,5	35°	HF10	750.097
	12	1,5	45°	HF21	752.501
8,6	12	1,5	35°	HF10	750.095
9,0	12	1,5	35°	HF10	750.096
9,6	12	1,5	35°	HF10	750.098
	12	1,5	45°	HF21	752.502
10,5	12	1,5	35°	HF10	750.200
11,0	12	1,5	35°	HF10	750.209
11,6	12	1,5	35°	HF10	750.099
	12	1,5	45°	HF21	750.503
13,0	12	1,5	35°	HF10	750.202
14,6	12	1,5	35°	HF10	750.201
15,0	12	1,5	35°	HF10	750.101
	12	1,5	45°	HF21	750.504
15,7	12	1,5	35°	HF10	750.203
16,0	12	1,5	35°	HF10	750.206
17,0	12	1,5	35°	HF10	750.115
17,6	12	1,5	35°	HF10	750.205
19,6	12	1,5	35°	HF10	750.208
20,0	12	1,5	35°	HF10	750.102
	12	1,5	35°	HF01	751.104
	12	1,5	35°	FMG02	752.101
	12	1,5	45°	HF21	752.505
21,6	12	1,5	35°	HF10	750.204
24,7	12	1,5	35°	HF10	750.103
$\alpha = 45^\circ$					
7,5	12	1,5	45°	HF21	752.501
9,6	12	1,5	45°	HF21	752.502
11,6	12	1,5	45°	HF21	752.503
15,0	12	1,5	45°	HF21	752.504
20,0	12	1,5	45°	HF21	752.505

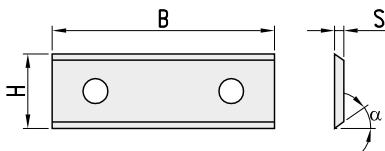

Ausführung 2: 2 Schneidkanten, 2 Löcher
Type 2: 2 cutting edges, 2 holes
HW

B	H	S	α	Körnung/Grain	Art. Nr.
$\alpha = 35^\circ$					
30	12	1,5	35°	HF10	750.104
30	12	1,5	35°	HF01	751.105
30	12	1,5	35°	FMG02	752.102
40	12	1,5	35°	HF10	750.105
50	12	1,5	35°	HF10	750.106
50	12	1,5	35°	HF01	751.107
50	12	1,5	35°	FMG02	752.103
60	12	1,5	35°	HF10	750.107
80	12	2,2	35°	HF10	750.108
100	12	2,2	35°	HF10	750.109
120	12	2,2	35°	HF10	750.110
$\alpha = 45^\circ$					
30	12	1,5	45°	HF21	752.507
40	12	1,5	45°	HF21	752.508
50	12	1,5	45°	HF21	752.509
60	12	1,5	45°	HF21	752.510
80	12	2,2	45°	HF21	752.511

753/4

HW Wendemesser 4-seitig
TC Reversible knives 4-cutting edges

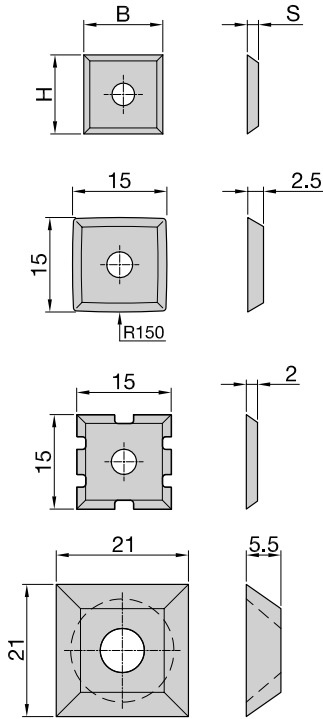
PG
02



Ausführung 1 - Type 1

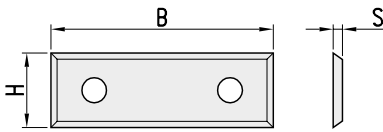

Ausführung 2 - Type 2

Ausführung 1: 4 Schneidkanten, 1 Senkloch
Type 1: 4 cutting edges, 1 sinkhole

HW

B	H	S	Körnung/Grain	Art. Nr.
12,0	12,0	1,5	HF10	754.102
	12,0	1,5	FMG02	752.100
14,0	14,0	2,0	HF10	750.111
	14,0	1,7		750.112
	14,0	1,2		750.113
14,3	14,3	2,5		750.116
15,0	15,0	2,0	SPB/Chipbreaker	754.301
	15,0	2,5	ballig	754.106
17,0	17,0	2,0	HF10	754.104
19,0	19,0	2,0	HF10	754.105
21,0	21,0	5,5		754.302

- HF21:** Für Weichholz
For Softwood
 - HF10:** Standardqualität
For wood
 - HF01:** Für MDF und abrasive Werkstoffe
For abrasive materials (chipboard/MDF)
 - FMG02:** Für MDF und HDF
For MDF and HDF
 - KCR08:** Für erhöhte Standzeiten
For longer endurance
- Auf Anfrage - *On request*

Ausführung 2: 4 Schneidkanten, 2 Löcher
Type 2: 4 cutting edges, 2 holes

HW

B	H	S	Körnung/Grain	Art. Nr.
29,5	9	1,5	HF10	753.204
	12	1,5	HF10	753.207
49,5	9	1,5		753.204
	12	1,5	HF10	753.307
50,0	12	1,7	HF10	753.350

753/4

HW Wendemesser mit Fase
TC Reversible knives with chamfer

PG
02

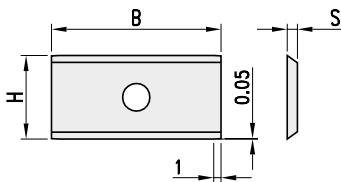

Für Aufbausystem
For built-up system

HW

B	H	S	Art. Nr.
20,0	12	1,5	755.101
24,7	12	1,5	755.102
30,0	12	1,5	755.103
50,0	12	1,5	755.105



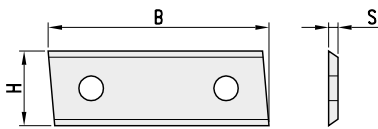

Ausführung 1 - Type 1

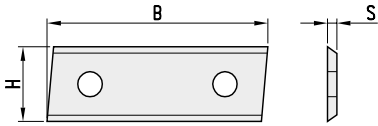

Ausführung 2 - Type 2

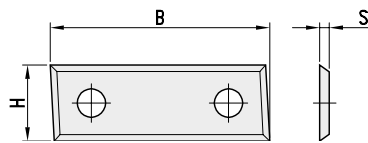

Ausführung 2 - Type 2

Ausführung mit 2 Schneidkanten
Type with 2 cutting edges

HW

B	H	S	Art. Nr.
Ausführung 1 - Type 1			
20	12	1,5	757.101
30	12	1,5	757.102
50	12	1,5	757.103
Ausführung 2 - Type 2			
20	12	1,5	757.201
30	12	1,5	757.202
50	12	1,5	757.203

Ausführung mit 4 Schneidkanten
Type with 4 cutting edges

HW

B	H	S	Art. Nr.
29,5	9	1,5	757.500
	12	1,5	757.150
49,5	9	1,5	757.501
	12	1,5	757.151

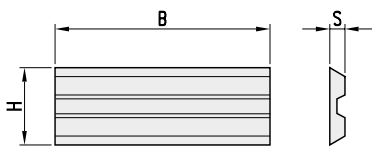

Ausführung 1 - Type 1



Ausführung 2 - Type 2

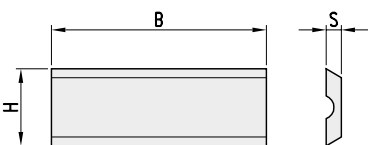

Ausführung 3 - Type 3

Ausführung 1
Type 1

HW

B	H	S	Art. Nr.
12	5,5	1,1	758.101
20	5,5	1,1	758.102
30	5,5	1,1	758.103
40	5,5	1,1	758.104
50	5,5	1,1	758.105

Ausführung 2
Type 2

HW

B	H	S	Art. Nr.
20	4,1	1,1	758.411
20	5,5	1,1	758.511
25	5,5	1,1	758.512
30	5,5	1,1	758.503
40	5,5	1,1	758.504
50	5,5	1,1	758.505

Ausführung 3
Type 3

HW

B	H	S	Art. Nr.
12	5,5	1,1	758.301
20	5,5	1,1	758.302
30	5,5	1,1	758.303
40	5,5	1,1	758.304
50	5,5	1,1	758.305

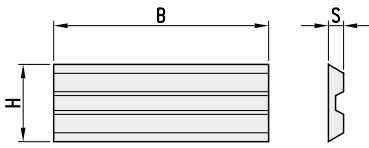
Ausführung mit 2 Schneidkanten
Type with 2 cutting edges
HW

B	H	S	Maschine	Art. Nr.
56,0	5,5	1,1	Adler	759.101
60,0	5,5	1,1		759.102
71,0	5,5	1,1		759.103
75,5	5,5	1,1	AEG TH75	759.104
			Bosch 0590,P400, 1590, 1591	
			Festo REP 75	
			Haffner FH 222	
			Holz-Her 2223, 2286, 2320	
			Kress Jet Star 6701, EH 6702	
			Mafell HU 75	
			Metabo 6375	
			Scheer MH 80, MH 75/3	
			Skill 98 H	
75,7	5,5	1,1	B & Decker DN 750, BD 750	759.105
			SR 600K	
78,0	5,5	1,1	Virutex (E) HTH75A	759.110
80,5	5,9	1,2	Elu MFF80, MFF 40	759.106
			ADE 80	
82,0	5,5	1,1	AEG EH 82, EH 82S, EH 822	759.107
			EH700, EH450	
			Fein HS 2151	
			Haffner FH 224	
			Hitachi F20, F20A, P20 SA, P 10V	
			F20 20A, FU 20 SA	
			Mafell EHU 82, MHU 82, MHU 82D	
			Makita 1100,1125B, 1900B, 1923B	
			1923 H, 1001, 1901, 1923 HO	
			Metabo Gustav, 4382, HO 0882	
			Bosch PH0 150, 100, 200, 300	
82,7	5,5	1,1	B& Decker DN 710, Dn 172, DN 730	759.109
			P71-02, PL 806	

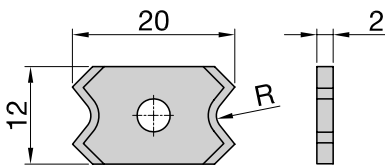

Radius-Kantenmesser, Ausführung mit 2 Schneidkanten
Radius-knife, type for scraper with 2 cutting edges
HW

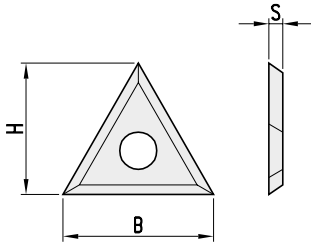
B	H	S	Art. Nr.
12	20	2	798.101
	20	2	798.102
	20	3	798.103
	20	4	798.104
	20	5	798.105

760**HW Dreiecks Wendemesser**
*TC Triangle reversible knives***PG**
02**Ausführung mit 3 Schneidkanten**
*Type with 3 cutting edges***HW**

B	H	S	R	Art. Nr.
22	19	2		760.101
	19	2	1	RH 760.201
	19	2	1	LH 760.202

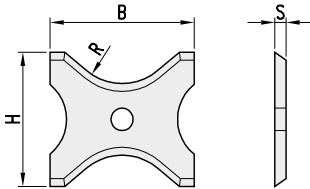
- ▲ Dreieckswendemesser mit gerundeten Kanten (R=1) für Innenkontur
- ▲ *Triangle Knives with rounded edges for inner contour*

761**HW Radius Wendemesser**
*TC Radius reversible knives***PG**
02**Ausführung mit 2 Schneidkanten**
*Type with 2 cutting edges***HW**

B	H	S	R	Art. Nr.
13	16	2	2	761.101
	16	2	3	761.102
	16	2	4	761.103
20	21	2	5	761.104
	21	2	6	761.105
	21	2	7	761.106
	21	2	8	761.107
26	24	2	9	761.108
	24	2	10	761.109
	24	2	11	761.110
	24	2	12	761.111
	24	2	13	761.112
30	25	2	14	761.113
	25	2	15	761.114
	25	2	16	761.115

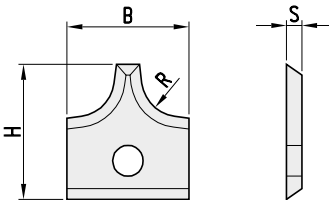
765**HW Radius Wendemesser**
*TC Radius reversible knives***PG**
02**Ausführung mit 2 Schneidkanten**
*Type with 2 cutting edges***HW**

B	H	S	R	Art. Nr.
16	17,5	2	2	765.101
	17,5	2	3	765.102
	17,5	2	4	765.103
	17,5	2	5	765.104
	17,5	2	6	765.105

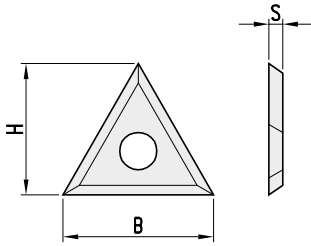
766**HW Räumler - Wendemesser**
TC Groovers - Reversible knives**PG**
02**Ausführung mit 4 Schneidkanten**
Type with 4 cutting edges**HW**

B	H	S	Art. Nr.
18	18	1,95	766.101
	18	2,45	766.102
	18	2,95	766.103

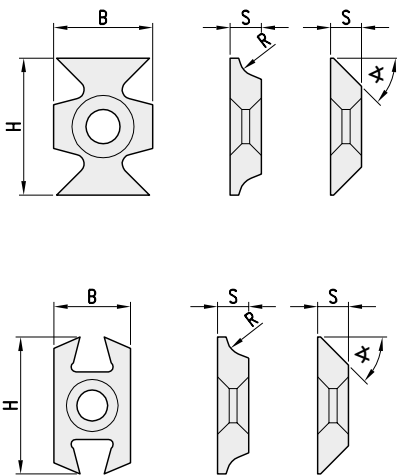
780**HW Kantenmesser**
TC Bevelling and rounding blades**PG**
02**Ausführung mit 2 Schneidkanten**
Type with 2 cutting edges**MEC****HW**

B	H	S	R	Art. Nr.
16	22	5	45°	780.103
	22	5	R1,5	780.205
	22	5	R2	780.207
	22	5	R2,5	780.208
	22	5	R3	780.206
	22	5	4	780.209
	22	5	5	780.210

Ausführung mit 2 Schneidkanten
Type with 2 cutting edges**MAN****HW**

B	H	S	R	Art. Nr.
16	29	5	45°	780.260
	29	5	R2	780.250
	29	5	R3	780.251

01



02



03



04



05



06



07



08



09



10



11



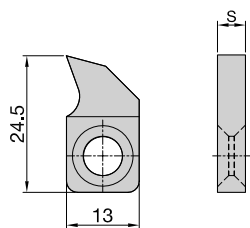

Ausführung mit 1 Schneidkanten
Type with 1 cutting edges
MEC**HW**

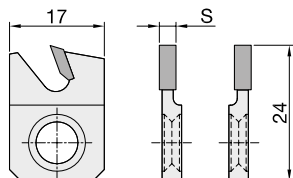
B	H	S	Art. Nr.
13	24,5	3	783.100
	24,5	4	783.101
	24,5	5	783.102
	24,5	6	783.103
	24,5	7	783.104

Ausführung MAN mit 1 Schneidkante
Type MAN with 1 cutting edge
MAN**HW**

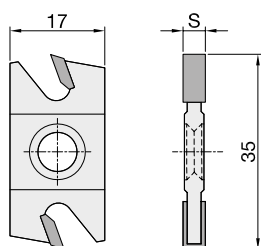
B	H	S	Art. Nr.
17	24	3	LH 783.125
	24	3	RH 783.126



Ausführung mit 2 Schneidkanten
Type with 2 cutting edges
MAN**HW**

B	H	S	Art. Nr.
17	35	4	783.120
	35	5	783.121
	35	6	783.122

771
773

HS/HW Streifenhobelmesser
HS/TC Planing knives

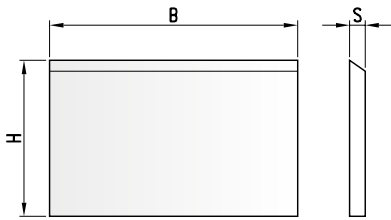
PG
02



HL/HS

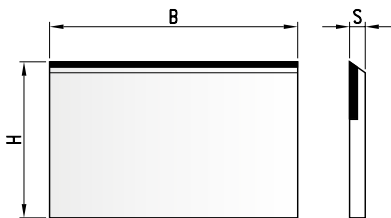

Hartmetallbestückt - Tipped knife

Ausführung mit 1 Schneidkanten
Type with 1 cutting edges

HS

HW

B	H	S	Art. Nr.	Art. Nr.
120	25	3	771.120.25	773.120.25
130		3	771.130.25	773.130.25
150		3	771.150.25	773.150.25
180		3	771.180.25	773.180.25
200		3	771.200.25	773.200.25
250		3	771.250.25	773.250.25
260		3	771.260.25	773.260.25
310		3	771.310.25	773.310.25
350		3	771.350.25	773.350.25
80	30	3	771.080.30	773.080.30
100		3	771.100.30	773.100.30
120		3	771.120.30	773.120.30
130		3	771.130.30	773.130.30
150		3	771.150.30	773.150.30
170		3	771.170.30	773.170.30
180		3	771.180.30	773.180.30
200		3	771.200.30	773.200.30
220		3	771.220.30	773.220.30
230		3	771.230.30	773.230.30
240		3	771.240.30	773.240.30
250		3	771.250.30	773.250.30
260		3	771.260.30	773.260.30
300		3	771.300.30	773.300.30
350		3	771.350.30	773.350.30
400		3	771.400.30	773.400.30
410		3	771.410.30	773.410.30
450		3	771.450.30	773.450.30
500		3	771.500.30	773.500.30
510		3	771.510.30	773.510.30
530		3	771.530.30	773.530.30
600		3	771.600.30	773.600.30
610		3	771.610.30	773.610.30
630		3	771.630.30	773.630.30
640		3	771.640.30	773.640.30
350	35	3	771.350.35	773.350.35
400		3	771.400.35	773.400.35
410		3	771.410.35	773.410.35
450		3	771.450.35	773.450.35
500		3	771.500.35	773.500.35
510		3	771.510.35	773.510.35
530		3	771.530.35	773.530.35
600		3	771.600.35	773.600.35
610		3	771.610.35	773.610.35
630		3	771.630.35	773.630.35

- Weitere Längen auf Anfrage
- *Different lengths upon request*

Für Elektrohandhobelmaschinen
For portable planers

HS

HW

B	H	S	Art. Nr.	Art. Nr.
78	25	3,2 Virutex	771.078.25	773.078.25
82	29	3,0 Makita	771.082.29	773.082.29



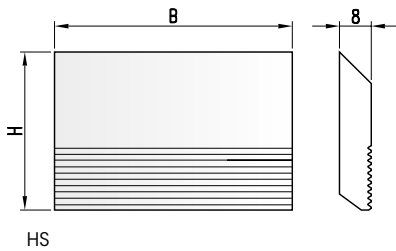

HS

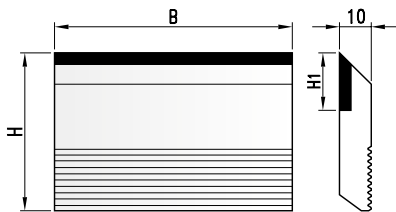

Hartmetallbestückt - Tipped knife

Mit 1 Schneidkante
With 1 cutting edge

HW

HS

B	H	H1	T	Art. Nr. HW	Art. Nr. HS
4mm-Blanketts					
40	30		4		774.040.30
60					774.060.30
80					774.080.30
100					774.100.30
180					774.180.30
240					774.240.30
650					774.650.30
40	35		4		774.040.35
60					774.060.35
80					774.080.35
100					774.100.35
180					774.180.35
240					774.240.35
650					774.650.35
5mm-Blanketts					
40	27	14	5	787.040.27	774.040.27
60				787.060.27	774.060.27
80				787.080.27	774.080.27
100				787.100.27	774.100.27
180				787.180.27	774.180.27
240				787.240.27	774.240.27
650				787.650.27	774.650.27
40	38	15	5	787.040.38	774.040.38
60				787.060.38	774.060.38
80				787.080.38	774.080.38
100				787.100.38	774.100.38
180				787.180.38	774.180.38
240				787.240.38	774.240.38
650				787.650.38	774.650.38
40	45	17	5	787.040.45	774.040.45
60				787.060.45	774.060.45
80				787.080.45	774.080.45
100				787.100.45	774.100.45
180				787.180.45	774.180.45
240				787.240.45	774.240.45
650				787.650.45	774.650.45
40	50		5		774.040.05
60					774.060.05
80					774.080.05
100					774.100.05
180					774.180.05
240					774.240.05
650					774.650.05

787
774

HW/HS Hobelmesser Blanketts - Rückenverzahnt
TC/HS Corrugated back knives

PG
02

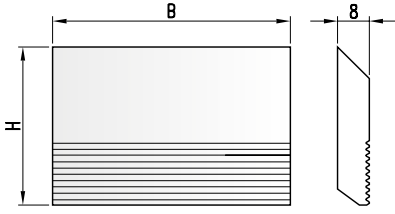

HS

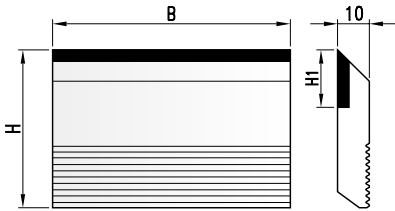

Hartmetallbestückt - Tipped knife

Mit 1 Schneidkante
With 1 cutting edge

HW

HS

B	H	T	Art. Nr. HS
6mm-Blanketts			
40	40	6	774.040.40
60			774.060.40
80			774.080.40
100			774.100.40
180			774.180.40
240			774.240.40
650			774.650.40
40	50	6	774.040.51
60			774.060.51
80			774.080.51
100			774.100.51
180			774.180.51
240			774.240.51
650			774.650.51
40	60	6	774.040.06
60			774.060.06
80			774.080.06
100			774.100.06
180			774.180.06
240			774.240.06
650			774.650.06
40	70	6	774.040.07
60			774.060.07
80			774.080.07
100			774.100.07
180			774.180.07
240			774.240.07
650			774.640.07

- Weitere Längen auf Anfrage
- *Different lengths upon request*



787
774

HW/HS Hobelmesser Blanketts - Rückenverzahnt
TC/HS Corrugated back knives

PG
02

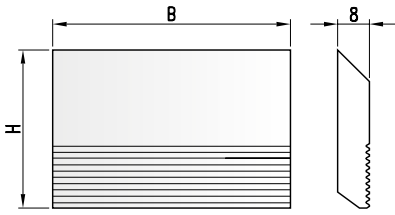

HS

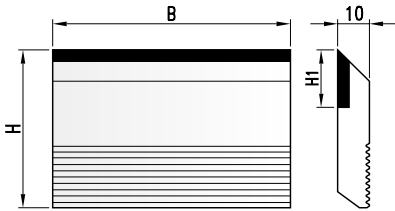

Hartmetallbestückt - *Tipped knife*

Mit 1 Schneidkante
With 1 cutting edge

HW

HS

B	H	H1	T	Art. Nr. HW	Art. Nr. HS
8mm-Blanketts					
40	50	15	8	787.040.50	774.040.50
60				787.060.50	774.060.50
80				787.080.50	774.080.50
100				787.100.50	774.100.50
130				787.130.50	774.130.50
150				787.150.50	774.150.50
180				787.180.50	774.180.50
230				787.230.50	774.230.50
635				787.645.50	774.635.50
650					774.650.50
40	60	20	8	787.040.60	774.040.60
60				787.060.60	774.060.60
80				787.080.60	774.080.60
100				787.100.60	774.100.60
130				787.130.60	774.130.60
150				787.150.60	774.150.60
180				787.180.60	774.180.60
230				787.230.60	774.230.60
635				787.635.60	774.635.60
650					774.650.60
40	70	25	8	787.040.70	774.040.70
60				787.060.70	774.060.70
80				787.080.70	774.080.70
100				787.100.70	774.100.70
130				787.130.70	774.130.70
150				787.150.70	774.150.70
180				787.180.70	774.180.70
230				787.230.70	774.230.70
635				787.635.70	774.635.70
650					774.650.70

- Weitere Längen auf Anfrage
- *Different lengths upon request*

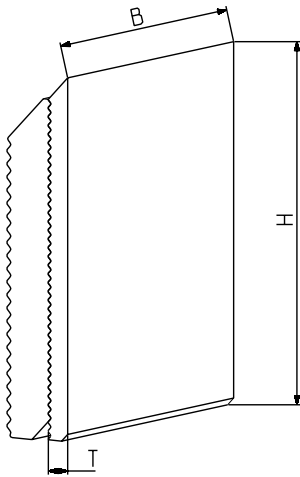
792
HW Hobelmesser mit Mikroverzahnung - Massiv
TC Micro corrugated planerknife - Solid
PG
02
Mit 1 Schneidkante
With 1 cutting edge
HW

B	H	T	Art. Nr.
40	38	3,2	792.040.038
60	38	3,2	792.060.038
80	38	3,2	792.080.038
100	38	3,2	792.100.038
150	38	3,2	792.150.038
170	38	3,2	792.170.038
40	50	3,2	792.040.050
50	50	3,2	792.050.050
60	50	3,2	792.060.050
80	50	3,2	792.080.050
100	50	3,2	792.100.050
120	50	3,2	792.120.050
40	60	3,2	792.040.060
50	60	3,2	792.050.060
60	60	3,2	792.060.060
80	60	3,2	792.080.060
100	60	3,2	792.100.060
120	60	3,2	792.120.060
130	60	3,2	792.130.060
150	60	3,2	792.150.060

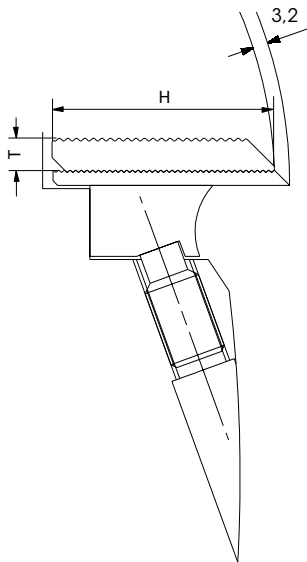
793
WS Stützplatte mit Mikroverzahnung und Rückenverzahnung
WS Micro corrugated and backserrated support
PG
02
Beidseitig verzahnte Stützplatte
Backing plate corrugated on both sides
HW

B	H	T	Art. Nr.
40	35	7,1	793.040.035
50	35	7,1	793.050.035
60	35	7,1	793.060.035
100	35	7,1	793.100.035
40	47	7,1	793.040.047
50	47	7,1	793.050.047
60	47	7,1	793.060.047
80	47	7,1	793.080.047
100	47	7,1	793.100.047
130	47	7,1	793.130.047
150	47	7,1	793.150.047
170	47	7,1	793.170.047
40	57	7,1	793.040.057
50	57	7,1	793.050.057
60	57	7,1	793.060.057
70	57	7,1	793.070.057
80	57	7,1	793.080.057
90	57	7,1	793.090.057
100	57	7,1	793.100.057
110	57	7,1	793.110.057
120	57	7,1	793.120.057
130	57	7,1	793.130.057

01



02



03



04



05



06



07



08



09



10



11

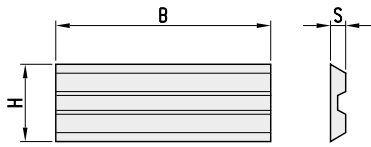

776
796**HS/HW „CentroLock“ Hobelmesser - Wendemesser**
*HS/TC „CentroLock“ knives - Reversible knives***PG**
02**CentroLock Wendemesser**
*CentroLock reversible knives***HW****HS**

B	H	S	Art. Nr. HS	Art. Nr. HW
20	16	3	776.020.016	796.020.016
60	16	3	776.060.016	796.060.016
70	16	3	776.070.016	796.070.016
80	16	3	776.080.016	796.080.016
85	16	3	776.085.016	796.085.016
100	16	3	776.100.016	796.100.016
110	16	3	776.110.016	796.110.016
130	16	3	776.130.016	796.130.016
150	16	3	776.150.016	796.150.016
160	16	3	776.160.016	796.160.016
170	16	3	776.170.016	796.170.016
180	16	3	776.180.016	796.180.016
190	16	3	776.190.016	796.190.016
200	16	3	776.200.016	796.200.016
210	16	3	776.210.016	796.210.016
220	16	3	776.220.016	796.220.016
230	16	3	776.230.016	796.230.016
240	16	3	776.240.016	796.240.016
250	16	3	776.250.016	796.250.016
260	16	3	776.260.016	796.260.016
270	16	3	776.270.016	796.270.016
275	16	3	776.275.016	796.275.016
280	16	3	776.280.016	796.280.016
290	16	3	776.290.016	796.290.016
310	16	3	776.310.016	796.310.016
350	16	3	776.350.016	796.350.016
360	16	3	776.360.016	796.360.016
450	16	3	776.450.016	796.450.016
460	16	3	776.460.016	796.460.016

- Weitere Längen auf Anfrage
- *Different lengths upon request*

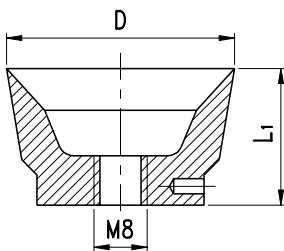
3458**HS Messer für Kopiereinheit**
*HS Tool for copying lathe***PG**
02**Rundmesser**
*Round type***HS**

D	L1	Art. Nr.
22	15	3458.022.015
30	19	3458.030.019
35	20	3458.035.020
45	26	3458.045.026
50	26	3458.050.026

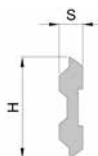
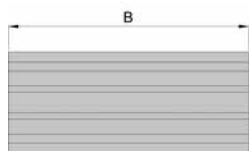
759
859**HS/HW „Tersa“ Hobelmesser - Wendemesser**
HS/TC „Tersa“ knives - Reversible knives**PG**
02**Ausführung mit 2 Schneidkanten**
*Type with 2 cutting edges***HS****HW**

B	H	S	Art. Nr. HS	Art. Nr. HW
60	10	2,3	759.060.010	859.060.010
80	10	2,3	759.080.010	859.080.010
100	10	2,3	759.100.010	859.100.010
110	10	2,3	759.110.010	859.110.010
130	10	2,3	759.130.010	859.130.010
150	10	2,3	759.150.010	859.150.010
170	10	2,3	759.170.010	859.170.010
210	10	2,3	759.210.010	859.210.010
230	10	2,3	759.230.010	859.230.010
260	10	2,3	759.260.010	859.260.010
280	10	2,3	759.280.010	859.280.010
310	10	2,3	759.310.010	859.310.010
330	10	2,3	759.330.010	859.330.010
360	10	2,3	759.360.010	859.360.010
410	10	2,3	759.410.010	859.410.010
450	10	2,3	759.450.010	859.450.010
510	10	2,3	759.510.010	859.510.010
610	10	2,3	759.610.010	859.610.010
640	10	2,3	759.640.010	859.640.010
710	10	2,3	759.710.010	
810	10	2,3	759.810.010	
910	10	2,3	759.910.010	

- Nur zur Verwendung in Tersa-Messerköpfen
- Weitere Längen auf Anfrage
- *Only for use in Tersa-cutterheads*
- *Different lengths upon request*

01



Säge

02



Hobeln

03



Hobeln / Fräsen

04



Profilösen

05



Nub- und Federlösen

06



Ob-erfräsen

07



Bohren

08



PKD-Werkzeuge

09



Spannen

10



Ersatzteile

11

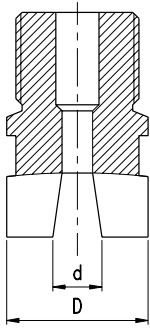

Informationen

3488**HS Stabschneider**
*HS Cutter for wire drawing straight slats***PG
02****Stabschneider**
*Wire drawing straight slat cutter***HS**

D	L1	Art. Nr.
25	6,2	3488.025.006
	8,2	3488.025.008
	10,2	3488.025.010
	12,2	3488.025.012

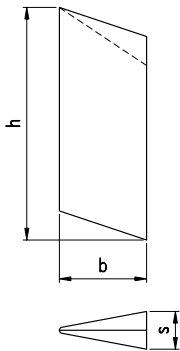
3910**HW/HS/ST Abstechstahl**
*TC/HS/ST Tool for copying lathe***PG
02****Abstechstahl**
*Copying lathe tool***HS**

b	s	h	Schneidstoff/material	Art. Nr.
25	9,5	100	HS/HS	3910.025.010
	9,5	100	ST/Stellite	3910.025.110
	9,5	100	HW/TC	3910.025.210
40	15,0	110	HS/HS	3910.040.015
	15,0	110	ST/Stellite	3910.040.115
	15,0	110	HW/TC	3910.040.215

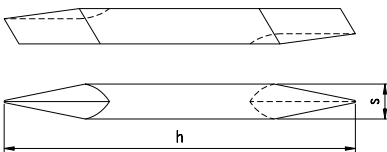
3910**HS Abstechstahl**
*HS Tool for copying lathe***PG
02****Abstechstahl**
*Copying lathe tool***HS**

D	L1	Art. Nr.
16	150	3910.016.150
20	200	3910.020.200

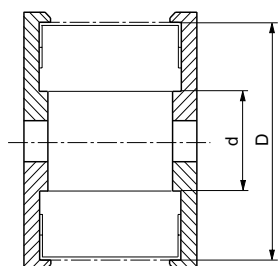
Einstell-Lehre
Adjustment gauge
HSEinstell-Lehre - *Adjustment gauge***Art. Nr.**
717.600
Messer - Einstell-Lehre
Knife - Adjustment gauge

D	d	Art. Nr.
125	30	717.201
140		717.202
150		717.203
125	40	717.204
140		717.205
150		717.206
125	50	717.207
140		717.208
150		717.209
163	50	717.210

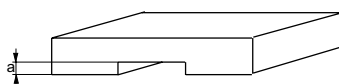
Messer - Einstell-Lehre
Knife - Adjustment gauge

a	Art. Nr.
1	717.302
0,3/0,8	717.309
0,3/1,3	717.310



Gewindestifte und Schrauben
Set-screws and screws

DIN 915



DIN 916

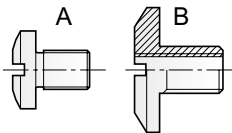
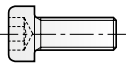
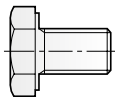
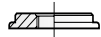
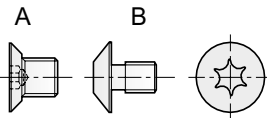
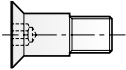

D	Art. Nr.	
Gewindestift mit Innensechskant und Zapfen - DIN 915 Hex socket setscrew		
M5 x 12	705.523	
M5 x 16	705.582	
M6 x 10	705.532	
M6 x 12	705.533	
M6 x 16	705.535	
M8 x 12	705.541	
M8 x 16	705.542	
M8 x 20	705.544	
M8 x 25	705.543	
M10 x 16	705.551	
M10 x 20	705.552	
M10 x 25	705.553	
M12 x 20	705.556	
Gewindestift mit Innensechskant und Kegelpuppe - DIN 916 Slotted countersink screw		
M2,5 x 2,5	705.100	
M4 x 4	705.101	
M5 x 5	705.102	
M5 x 8	705.511	
M5 x 10	705.103	
M6 x 6	705.583	
Zylinderschraube-Senkopf mit Innensechskant - Countersink with collar		
M5 x 13,5	705.318	
TORX-Schrauben - Screw TORX		
M4 x 3,2	Ausführung /Type A	705.313
M4 x 4,2		705.314
M5 x 7		705.425
M3,5 x 7,5	Ausführung /Type B	705.350
M3,5 x 4		705.352
M4 x 4		705.353
M4 x 6		705.351
M4 x 9		705.354
Torxmuttern für Wendeschneidmesser - Special nut for groover		
M4 x 1,6 (Ø9,9)		709.128
M4 x 1,7 (Ø11,9)		709.129
M4 x 2,3 (Ø11,9)		709.127
Sechskantschrauben mit Gewinde bis zum Kopf - Hex head screw		
M10 x 12		705.432
M10 x 17		705.433
Zylinderschraube mit Innensechskant - Hex socket cap screw		
1/8"		705.501
3/32"		705.502
Spezial-Rundkopfschraube - Special round head screw		
M5 x 7/Ø10	Ausführung /Type A	705.217
M5 x 7/Ø16		705.214
M6 x 6/Ø16	Ausführung /Type B	705.218

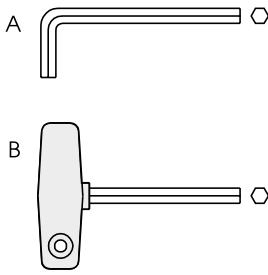
**Sechskantschlüssel**
Hex wrench**HS**

Dim.		Art. Nr.
SW 3/32"	Ausführung/Type A	706.161
SW 5/64"		706.162
SW 1,3		706.149
SW 1,5		706.150
SW 2		706.151
SW 2,5		706.152
SW 3		706.153
SW 4		706.154
SW 5		706.155
SW 6		706.156
SW 2,5	Ausführung/Type B	706.102
SW 3		706.103
SW 4		706.104
SW 5		706.105
SW 6		706.106
SW 10		706.107

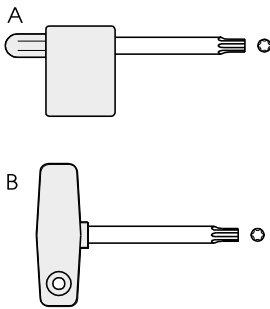
**TORX-Schlüssel**
TORX Wrench

Dim.		Art. Nr.
TX9		706.301
TX15	Ausführung/Type A	706.302
TX9		706.303
TX15	Ausführung/Type B	706.304
TX20		706.305

Drehmomentadapter für Bit 6kt. S=6,35mm auf Bit-Schaft 6kt. S=6,35mm zur korrekten Vorspannung von Wendeplatten mit Torx-Schrauben

Torque adapter for bit hex. S=6.35mm to bit shank hex. S=6.35mm for correct pretensioning of inserts with Torx screws

Einzelner Drehmomentadapter in Ausführung auch zum Betrieb in Handbohrmaschinen geeignet
Single torque adapter in version also suitable for operation in hand drills

M[Nm]	TX	Art. Nr.
Voreingestelltes Drehmoment Set inkl. div. Torx Bits, T-Griff und Drehmomentadapter <i>Pre-set torque set incl. various Torx bits, T-handle and torque adapter</i>		
2,0 Nm	TX09	923.009.20
3,0 Nm	TX15	923.015.30
5,5 Nm	TX20	923.025.50

Set für eine Torx-Größe inkl. T-Griff Schlüssel und Torx-Bits mit unterschiedlicher Länge
Set for one Torx size incl. T-handle spanner and Torx bits with different lengths

M[Nm]	TX	Art. Nr.
Drehmomentadapter Sets - Voreingestelltes Drehmoment - <i>Torque adapter sets - Pre-set torque</i>		
2,0 Nm	TX09	922.009.20
3,0 Nm	TX15	922.015.30
5,5 Nm	TX20	922.020.55

Set für unterschiedliche Torx-Größen inkl. T-Griff Schlüssel und div. Torx-Bits für gelistete Torx-Größen
Set for different Torx sizes incl. T-handle spanner and various Torx bits for listed Torx sizes

M[Nm]	TX	Art. Nr.
Set inkl. div. Torx Bits TX6-TX20 und T-Griff mit div. Drehmomenten <i>Set incl. various Torx bits TX6-TX20 and T-handle with various torques</i>		
0,6 Nm	TX6	
0,9 Nm	TX7	
1,2 Nm	TX8	
2,0 Nm	TX9	
3,0 Nm	TX15	
5,5 Nm	TX20	

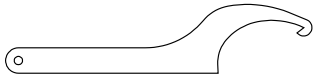

**Hakenschlüssel**
Hook Wrench

D min. - D max.	L	Für Spannmuttern	Art. Nr.
30/32	136	426E/ER16	706.505
34/36	170	428E/ER20	706.507
40/42	170	430E/ER25	706.500
45/50	206	470E/ER32	706.504
58/62	240	462E/OZ25	706.503
68/75	240	472E/ER40	706.501
80/90	280	477E/ER50 468E/OZ40	706.502

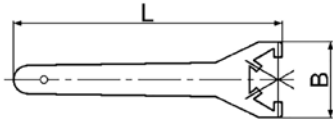
**Schlüssel für Mutter mit 6 Nuten**
Spanner for nuts with 6 grooves

L	B	Für Spannmuttern	Art. Nr.
163	50	ER16	706.016
180	60	ER20	706.701
210	65	ER25	706.711
253	75	ER32	706.709
290	88	ER40	706.715
350	110	ER50	706.71

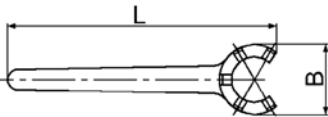
**Schlüssel für Minimuttern**
Spanner for mini nuts

L	B	Für Spannmuttern	Art. Nr.
117	22,5	ER16	706.716
128	28	ER20	706.714
145	36	ER25	706.712

**HSK85WS Montagestand**
HSK85WS assemblystand**HS**

Bezeichnung	Art. Nr.
HSK85WS-Messspindel	835.250.015

**Messtisch mit Messuhr**
Table of geometric control**HS**

Art. Nr.
719.101

723

Hobelmesser-Schneidenflugkreis-Prüf- und Einstellhilfe

Control device for planing knives

PG
02

Messer Prüf- und Einstellhilfe
Control device for knives

HS

Art. Nr.
835.250.015

4000
4400

Entharzer - Sprühflasche

Cleaning liquid-aerosol can

PG
02

Cleaner Universal Reinigungsmittel
Cleaning liquid

Bezeichnung	Verpackungseinheit	Art. Nr.
1 Liter Sprühflasche Entharzer für Alu-Werkzeuge	6	4400.0100
1 Liter Entharzer für Stahl-Werkzeuge	1	4000.0100

Schnellentharzer für universelle Verwendung. Beseitigt normale und schwierige, organische und anorganische Verschmutzungen auf sämtlichen Werkzeugen.

- Keine gesundheitsschädlichen Inhaltsstoffe.
- Biologisch abbaubar.
- Reinigt schnell und rückstandsfrei

Resin cleaning agent for removal of resin and cleaning of tools.

- No noxious ingredients
- biodegradable
- Cleans quick and residue-free

Achtung: Es lohnt sich Werkzeuge öfters zu entharnzen. Verharzte Werkzeuge verringern erheblich die Standwege, verschlechtern die Schnittgüte und erhöhen die Stromkosten.

Attention: It's worth to clean tool frequently. Resined tools shorten tool life, worsen quality of cut and heighten electricity costs.

4000
4400

Entharzer für Werkzeuge aus Stahl und Aluminium

Cleaner for steel- and aluminium-tools

PG
02

AX-Entharzer für Aluminium-Werkzeuge
AX-Cleaner for Alu-tools

Bezeichnung	Verpackungseinheit	Art. Nr.
5 Liter Kanister Konzentrat	5l	4400.0500
Verdünnen 1:10 mit Wasser		

5 liter canister master batch, to dilute with 50 liter of water

Anwendung: Schnellentharzer für Werkzeug aus Aluminium

SX-Cleaner für Stahl
SX-Cleaning liquid for steel-tools

Bezeichnung	Verpackungseinheit	Art. Nr.
5 Liter Kanister Konzentrat	5l	4000.0500
Verdünnen 1:5 mit Wasser		

5 liter canister master batch, to dilute with 25 liter of water

Anwendung: Schnellentharzer für Werkzeug aus Stahl
Werkzeuge aus Aluminium dürfen mit dem Cleaner nicht in Berührung kommen.

Attention: Only for steel tools. Do not use for aluminium-tools.

