

ProChipper®



tooling systems



Spannsysteme, Zubehör
Clamping systems, accessoires

Type A

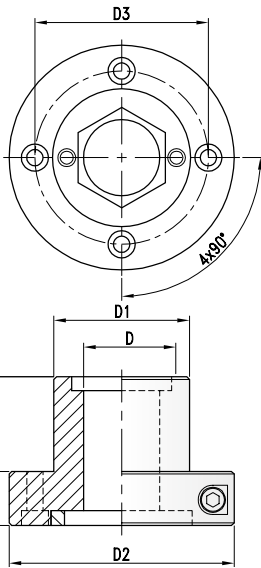

Type B

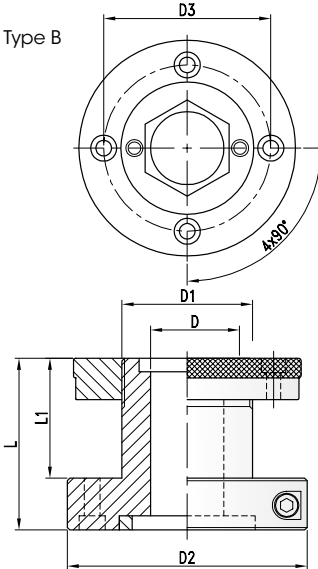
HydroGrip - Offenes Hydrodehnfutter mit Fettpumpenanschluss
HydroGrip - Open hydrosleeve with connection for grease pump

D	D1	D2	D4	L	L1	Art. Nr.
Type A						
30	40	83	64	55	35	724.101
	50	83	64	55	35	724.102
35	50	83	64	55	35	724.103
	60	93	74	55	35	724.105
40	50	83	64	55	35	724.104
	60	93	74	55	35	724.106
45	60	93	74	55	35	724.107
50	60	93	74	55	35	724.111

HydroGrip - Offenes Hydrodehnfutter mit Fettpumpenanschluss
HydroGrip - Open hydrosleeve with connection for grease pump

D	D1	D2	D3	D4	L	L1	L2	Art. Nr.
Type B								
30	50	83	83	64	75	40	55	724.201
35	50	83	83	64	75	40	55	724.202
	50	83	83	64	115	80	95	724.203
50	83	83	64	165	130	145		724.204
	60	93	90	74	75	40	55	724.205
60	93	90	74	115	80	95		724.206
	93	90	74	140	105	120		724.207
40	50	83	83	64	75	40	55	724.211
	50	83	83	64	115	80	95	724.213
50	83	83	64	140	105	120		724.215
	83	83	64	165	130	145		724.216
50	83	83	64	190	155	170		724.217
	60	93	90	64	75	40	55	724.218
60	93	90	74	115	80	95		724.220
	93	90	74	140	105	120		724.221
60	93	90	74	165	130	145		724.224
	93	90	74	215	180	195		724.226
45	60	93	90	74	75	40	55	724.228
	60	93	90	74	115	80	95	724.230
60	93	90	74	140	105	120		724.232
	93	90	74	190	155	170		724.234
60	93	90	74	240	205	220		724.236
	50	60	93	90	74	75	40	55
60	93	90	74	115	80	95		724.240
	93	90	74	140	105	120		724.242
60	93	90	74	190	155	170		724.243
	93	90	74	240	205	220		724.245

Zubehör
Attachment

Art. Nr.	
Fettpumpe - Grease pump	724.401
Fettkartusche - Grease cartridge	724.402

Type EI

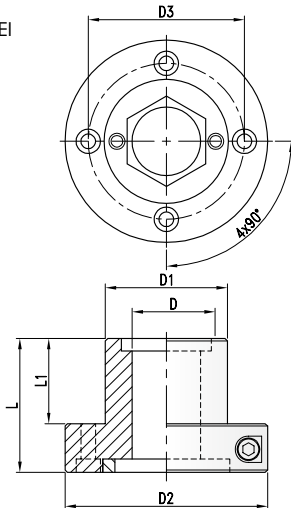
HydroGrip - Geschlossenes System
 HydroGrip - Closed System

D	D1	D2	D3	L	L1	Art. Nr.
Type EI						
40	60	120	100	92	68	724.301

Type EI

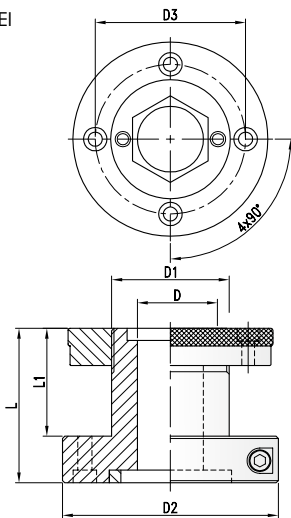
HydroGrip - Geschlossenes System
 HydroGrip - Closed System

D	D1	D2	D3	L	L1	Art. Nr.
Type EI						
40	60	120	100	92	68	724.350

- Hydrodehnfutter mit Feingwindemutter für stufenlos verstellbare Werkzeuge.
- *Macrothreaded hydro sleeve for grooving and flooring sets.*

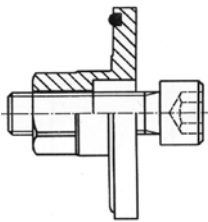
Deckscheibe für Perske Motor
 Flange for Perske motor

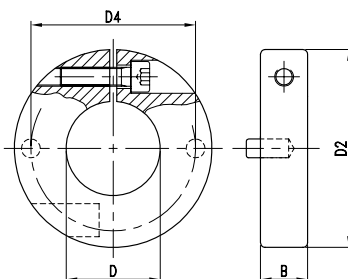
 Deckscheibe mit Sechskant - *Flange with hex. end*
Art. Nr.
724.403

Klemmring
 Locking ring

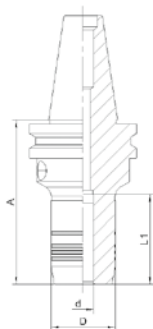
D	B	D2	D4	Art. Nr.
40	20	84	70	724.404.40
50	20	92	75	724.404.50

Hydrodehnfutter mit SK30-Schaftaufnahme
Hydrosleeve with ISO 30-shank

d	D	A	L2	S	Art. Nr.
10	28	55	38,5	SK30	85.010.073.030
3/8"	28	55	38,5	SK30	85.095.111.030
12	28	55	38,5	SK30	85.012.065.030
16	58	63	55	SK30	85.016.065.030
20	60	63	55	SK30	85.020.111.030
25	70	63	55	SK30	85.025.111.030

- ohne Anzugsbolzen
- *Without holding bolt*

Hydrodehnfutter mit ISO 30-Schaftaufnahme
Hydrosleeve with ISO 30-shank

d	D	A	L1	S	Art. Nr.
25	70	82	55	SK40	85.025.130.030

Hydro-Dehnspannfutter SK40
Hydraulic collet chuck SK40

d	D	A	L1	S	Art. Nr.
25	70	78	52	SK40	85.025.146.040

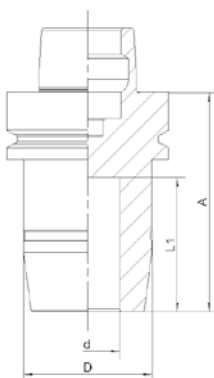

Hydro-Dehnfutter mit HSK-Schaftaufnahme
Hydrosleeve with SK 30-shank

d	D	A	L2	S	Art. Nr.
20	42	85	52	HSK50F	85.020.085.050
25	50	85	52	HSK50F	85.025.085.050
6	26	80	37	HSK63F	85.006.085.063
8	28	80	37	HSK63F	85.008.085.063
10	30	80	42	HSK63F	85.010.085.063
12	32	80	47	HSK63F	85.012.085.063
14	34	80	47	HSK63F	85.014.085.063
16	38	80	52	HSK63F	85.016.085.063
18	40	80	52	HSK63F	85.018.085.063
20	42	80	52	HSK63F	85.020.085.063
25	50	85	52	HSK63F	85.025.110.063
25	50	85	52	HSK63F	85.025.117.063

- ohne Anzugsbolzen
- *Without holding bolt*

Ersatzteile/Zubehör
Spare parts/Accessories

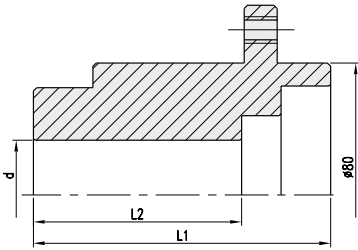
	Art. Nr.
Quergriffschlüssel SW6 - <i>Allen key SW6</i>	36.100.06
Anzugsbolzen - <i>retainingbolt</i>	A424.DIV

730**Flanschbüchse**
*Flange sleeve*PG
02**Starre Flanschbüchse**
Flange sleeve

L1	L2	d	TK	Art. Nr.
90	63	35 DKN	8/M8/100 Homag, IMA, Torwegge	730.101
97	68	40 DKN	8/M8/100 Schwabedissen, Gabianni	730.102

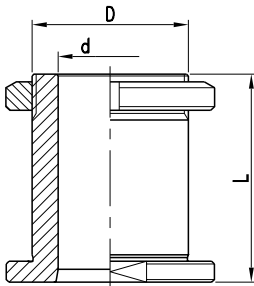
Zubehör
*Attachment*Schraube für Werkzeugmontage - *Screw for tool mounting*Art. Nr.
705.700.16**704****Schraubbüchse**
*Sleeve with locking nut*PG
02**Abmessungen**
Dimensions

d	D	L	I	Art. Nr. LH	Art. Nr. RH
30	50	85	63	704.271	704.171
	60	85	63	704.251	704.151
35	50	85	63	704.272	704.172
	60	85	63	704.252	704.152
40	50	85	63	704.273	704.173
	60	85	63	704.253	704.153
50	50	85	63	704.254	704.154
	60	85	63	704.264	704.164

Zubehör
*Attachment*Hakenschlüssel - *Hook wrench for*

D=50

Art. Nr.

706.501

D=60

706.502

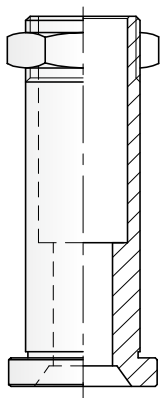
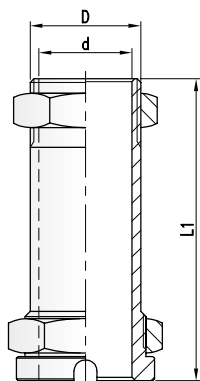

Abmessungen
Dimensions

D	L	d	Modell		Art. Nr.
32	140	27	TEKNA	TK610/Z	729.211.27
32	90	14		500	729.201.14
27	90	14		MN-75-AR	◇ 729.202.14
32	90	14		MN-75-AR	729.201.14
50	85	40	ELUMATEC	AF-221, AF-222, AF-223	729.173.40
32	75	20		MA-91	729.106.20
32	160	25	IM/CRS	OL - 94	729.208.25
32	100	27	TRE-C	INTEX 2500	◇ 729.203.27
32	150	27	LGF	BEBA	729.206.27
32	140	25		DIXI	729.204.25
32	200	25		DIXI	729.207.25
32	156	19		PHANTON - M	729.301.19
32	163	25		PHANTON - SK	729.105.25
32	150	27		FR 704, FR 706	729.206.27
				FR 702, FR 703, FR 712	
32	125	22	MIEPA	MP - 130	729.303.22
32	135	27		ML - 124/OS	729.205.27
32	135	27	OMC	FEROCE, FEROCE-A	729.209.27
				MÁXIMA, TIGRA, TIGRA-A	
32	135	27	OMGA	AL -132	729.205.27
32	135	27		ML - 120	729.205.27
32	135	27	RINALDI	LILIPUT 9M 7000 FS	729.205.27
32	145	22	TEKNA	TK-641	729.104
32	70	14		FV-100-M	729.102.14
22	70	14		FV-100-M	729.103.14
32	150	24		FV-140	729.304.24
32	173	25		FV-190-A	729.302.25
32	140	25	GREENMAC	GM 4590	729.204.25

- Andere Spannbüchsen zum Verschrauben von Werkzeugsätzen auf Anfrage.

- *Sleeves for other machines under request. On request please state machine and model.*

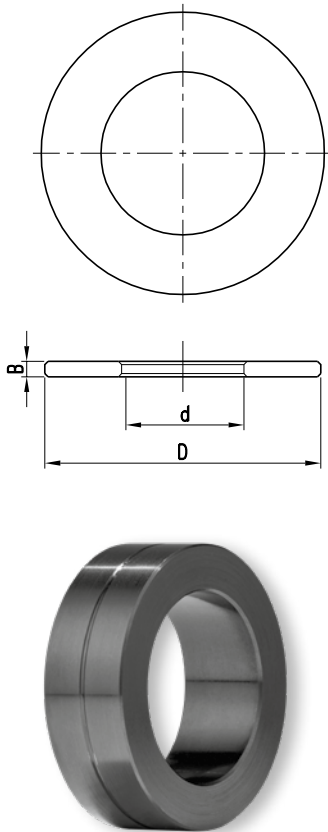
- ◇ Serienartikel, kurzfristige Fertigung bei Bestellung
- ◇ *Standard article, short-time production after order*

Zwischenringe aus Stahl
Steel-spacer

d	B	D	Art. Nr.
25,4	10,0	50	34.050.141
	20,0	50	34.050.142
	30,0	50	34.050.143
	40,0	50	34.050.144
30	0,1	50	34.050.077
	0,2	50	34.050.076
	0,5	50	34.050.075
	1,0	50	34.050.074
	2,0	50	34.050.073
	5,0	50	34.050.072
	7,0	50	34.050.071
	10,0	50	34.050.057
	20,0	50	34.050.058
	30,0	50	34.050.059
31,75	40,0	50	34.050.060
	50,0	50	34.050.061
	0,1	50	34.050.001
	0,2	50	34.050.325
	0,5	50	34.050.303
	1,0	50	34.050.004
	2,0	50	34.050.205
	5,0	50	34.050.081
	7,0	50	34.050.181
	10,0	50	34.050.082
32	20,0	50	34.050.083
	10,0	55	34.055.062
	20,0	55	34.055.063
	30,0	55	34.055.064
	40,0	55	34.055.065
	10,0	55	34.055.067
	20,0	55	34.055.068
	30,0	55	34.055.069
	40,0	55	34.055.070
	35	0,1	55
0,2		55	34.055.140
0,5		55	34.055.041
1,0		55	34.055.042
2,0		55	34.055.043
5,0		55	34.055.044
7,0		55	34.055.045
10,0		55	34.055.046
20,0		55	34.055.047
10,0		60	34.060.047
38,1	20,0	60	34.060.048
	30,0	60	34.060.049
	40,0	60	34.060.050
	10,0	60	34.060.061
	20,0	60	34.060.062
	30,0	60	34.060.063
	40,0	60	34.060.064

- Fortsetzung nächste Seite
- Continued next page

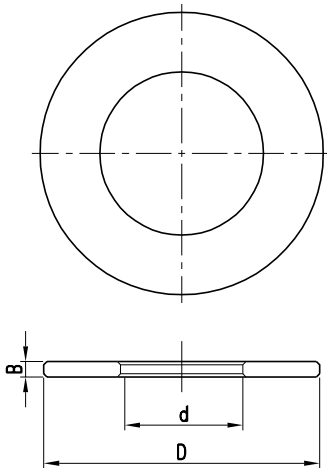
Zwischenringe aus Stahl
Steel-spacer

d	B	D	Art. Nr.
40	0,1	60	34.060.123
	0,2	60	34.060.124
	0,5	60	34.060.325
	1,0	60	34.060.126
	2,0	60	34.060.125
	5,0	60	34.060.328
	7,0	60	34.060.229
	10,0	60	34.060.027
	20,0	60	34.060.028
	30,0	60	34.060.029
45	0,1	65	34.065.090
	0,2	65	34.065.091
	0,5	65	34.065.092
	1,0	65	34.065.093
	2,0	65	34.065.094
	5,0	65	34.065.095
	7,0	65	34.065.096
	10,0	65	34.065.097
	20,0	65	34.065.098
	50	0,1	70
0,2		70	34.070.037
0,5		70	34.070.039
1,0		70	34.070.040
2,0		70	34.070.112
5,0		70	34.070.098
7,0		70	34.070.117
10,0		70	34.070.031
20,0		70	34.070.032
30,0		70	34.070.033
60	0,1	80	34.080.401
	0,2	80	34.080.402
	0,5	80	34.080.403
	1,0	80	34.080.404
	2,0	80	34.080.405
	5,0	80	34.080.406
	7,0	80	34.080.407
	10,0	80	34.080.041
	20,0	80	34.080.042

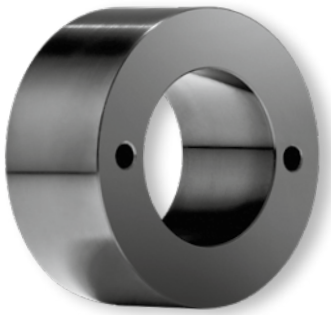
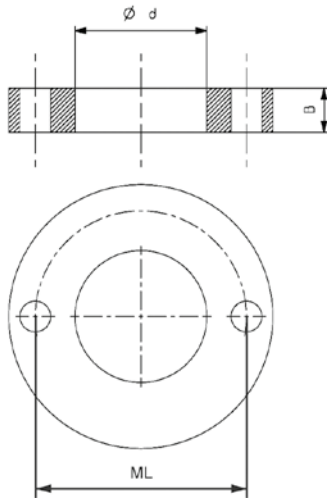
Stahl-Zwischenring mit Mitnahmelöchern
Steel-Spacer with pinholes

d	B	D	ML/TK	Art. Nr.
20	0,1	45	4/6/32	34.045.019
	0,2	45		34.045.120
	0,5	45		34.045.021
	1,0	45		34.045.022
	2,0	45		34.045.123
	5,0	45		34.045.024
	7,0	45		34.045.125
	10,0	45		34.045.025
20	0,1	50	2/7/38	34.050.050
	0,2	50		34.050.048
	0,5	50		34.050.051
	1,0	50		34.050.052
	2,0	50		34.050.053
	3,0	50		34.050.054
	5,0	50		34.050.055
	7,0	50		34.050.049
	10,0	50		34.050.056
30	0,5	60	2/7/48	34.060.081
	1,0	60		34.060.082
	2,0	60		34.060.083
	3,0	60		34.060.084
	5,0	60		34.060.085
	10,0	60		34.060.086
30	5,0	85	2/7/54	34.085.070
	10,0	85		34.085.071
	20,0	85		34.085.072
	30,0	85		34.085.073
	40,0	85		34.085.074
	50,0	85		34.085.075
30/35	0,1	65	4/7/48	34.065.010
	0,2	65		34.065.011
	0,3	65		34.065.053
	0,5	65		34.065.050
	1,0	65		34.065.051
	2,0	65		34.065.052
	5,0	65		34.065.055
	7,0	65		34.065.057
	10,0	65		34.065.060
	15,0	65		34.065.115
	20,0	65		34.065.116
40	5,0	85	2/7/54	34.085.052
	10,0	85		34.085.054
	20,0	85		34.085.055
	30,0	85		34.085.056
	40,0	85		34.085.057
	50,0	85		34.085.058
40	0,1	85	4/7/58	34.085.401
	0,2	85		34.085.402
	0,5	85		34.085.403
	1,0	85		34.085.404
	2,0	85		34.085.405
	5,0	85		34.085.406
	10,0	85		34.085.407
	15,0	85		34.085.408
	20,0	85		34.085.409

- Fortsetzung nächste Seite
- *Continued next page*



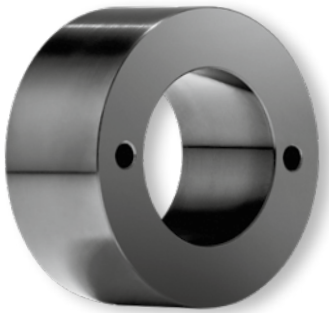
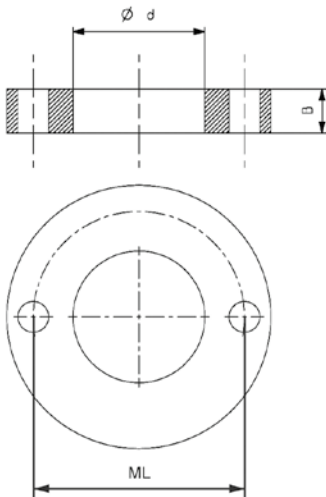

Stahl-Zwischenring mit Mitnahmelöchern
Steel-Spacer with pinholes

d	B	D	ML/TK	Art. Nr.
40/50	0,1	80	4/7/65	34.080.001
	0,2	80		34.080.002
	0,5	80		34.080.082
	1,0	80		34.080.010
	2,0	80		34.080.020
	5,0	80		34.080.050
	7,0	80		34.080.086
	10,0	80		34.080.087
	15,0	80		34.080.088
	20,0	80		34.080.089
50	5,0	85	2/7/64	34.085.090
	10,0	85		34.085.091
	20,0	85		34.085.092
	30,0	85		34.085.093
	40,0	85		34.085.094
	50,0	85		34.085.095
60	0,05	90	3/9/74	34.090.015
	0,1	90		34.090.083
	0,2	90		34.090.021
	0,3	90		34.090.022
	0,5	90		34.090.005
	1,0	90		34.090.040
	3,0	90		34.090.002
	5,0	90		34.090.014
	10,0	90		34.090.018
	15,0	90		34.090.043
20,0	90	34.090.044		

Zwischenringe zur Feineinstellung
Spacer rings for fine adjustment

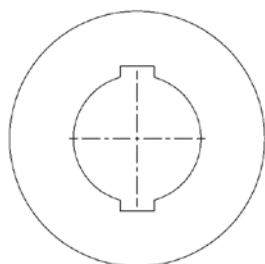
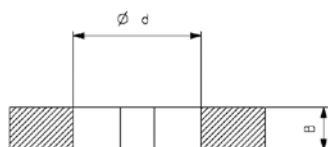
d	B	D	ML/TK	Art.Nr.
20	0,1	50	2/7/36	34.050.047
	0,05	50	2/7/36	34.050.015
30	0,1	60	2/7/48	34.060.079
	0,05	60	2/7/46	34.060.078

Zwischenringe - Präzisionsausführung mit Doppelkeilnut
Spacer ring set - High precision model with double keyway

d	B	D	DKN	Art. Nr.
20	1,0	36	6x2,8	34.036.010
	2,0	36		34.036.020
	5,0	36		34.036.050
	10,0	36		34.036.100
30	1,0	50	8x3,5	34.050.504
	2,0	50		34.050.502
	3,0	50		34.050.503
	5,0	50		34.050.505
	10,0	50		34.050.510
30	1,0	60	8x3,3	34.060.092
	2,0	60		34.060.093
	2,5	60		34.060.097
	3,0	60		34.060.094
	5,0	60		34.060.095
	10,0	60		34.060.096

Zwischenringe mit Doppelkeilnut zur Feineinstellung
Spacers with double keyway for fine adjustment

d	B	D	DKN	Art. Nr.
20	0,05	36	6x2,8	34.036.005
	0,1	36	6x2,8	34.036.001
30	0,05	50	8x3,3	34.050.005
	0,1	50	8x3,3	34.050.101
30	0,5	50	8x3,5	34.050.555
30	0,05	60	8x3,3	34.060.066
	0,1	60	8x3,3	34.060.090
	0,2	60	8x3,3	34.060.100
	0,5	60	8x3,3	34.060.091

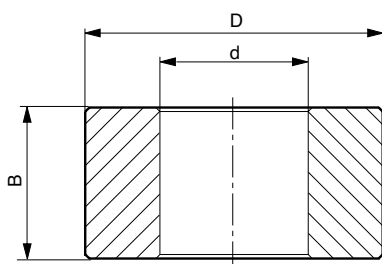

Stahl-Reduzierhülse
Steel-reducing sleeve

D	B	D	Art. Nr.
35	2	30	714.101
	5	30	714.102
	10	30	714.103
	15	30	714.104
	20	30	714.105
	30	30	714.106
	40	30	714.107
	50	30	714.108
40	2	30	714.251
	5	30	714.252
	10	30	714.253
	15	30	714.254
	20	30	714.255
	30	30	714.256
	40	30	714.257
	50	30	714.258
40	2	31,75	714.151
	5	31,75	714.152
	10	31,75	714.153
	15	31,75	714.154
	20	31,75	714.155
	30	31,75	714.156
	40	31,75	714.157
	50	31,75	714.158
40	2	35	714.201
	5	35	714.202
	10	35	714.203
	15	35	714.204
	20	35	714.205
	30	35	714.206
	40	35	714.207
	50	35	714.208
45	2	30	714.301
	5	30	714.302
	10	30	714.303
	15	30	714.304
	20	30	714.305
	30	30	714.306
	40	30	714.307
	50	30	714.308
50	2	30	714.451
	5	30	714.452
	10	30	714.453
	15	30	714.454
	20	30	714.455
	30	30	714.456
	40	30	714.457
	50	30	714.458
50	2	35	714.401
	5	35	714.402
	10	35	714.403
	15	35	714.404

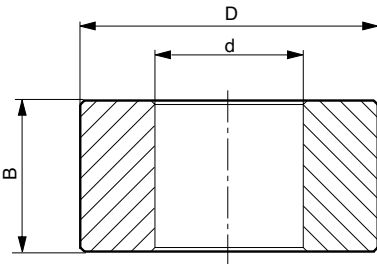
- Fortsetzung nächste Seite
- *Continued next page*

714**Reduzierhülse**
Reducing sleeve**PG**
02**Stahl-Reduzierhülse**
Steel-reducing sleeve

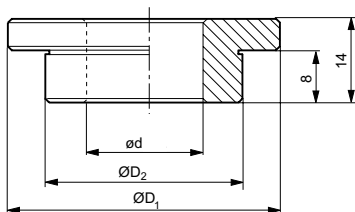
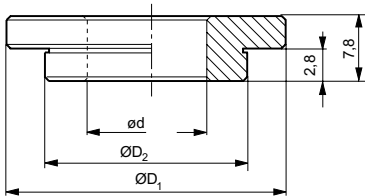
D	B	D	Art. Nr.
	20	35	714.405
	30	35	714.406
	40	35	714.407
	50	35	714.408
50	2	40	714.351
	5	40	714.352
	10	40	714.353
	15	40	714.354
	20	40	714.355
	30	40	714.356
	40	40	714.357
	50	40	714.358
50	2	45	714.501
	5	45	714.502
	10	45	714.503
	15	45	714.504
	20	45	714.505
	30	45	714.506

713**Reduzierring mit Bund**
Reducing sleeve with collar**PG**
02**Stahl-Reduzierring**
Steel-reducing sleeve

d	D ₂	D ₁	Art. Nr. Type 1	Art. Nr. Type 2
30	35	49	713.101	713.115
	40	54	713.102	713.116
	45	59	713.103	713.117
	50	64	713.104	713.118
31,75	35	49	713.105	713.119
	40	54	713.106	713.120
	45	59	713.107	713.121
	50	64	713.108	713.122
35	40	54	713.109	713.123
	45	59	713.110	713.124
	50	64	713.111	713.125
	50	64	713.112	713.126
40	45	50	713.113	713.127
	50	64	713.114	713.128
45	50	64	713.114	713.128

- Auslieferung erfolgt als Set von 2St.
- Supplied as set of 2pcs.

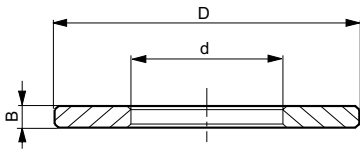

Stahl-Zwischenring
Steel-reducing sleeve

D	B	d	Art. Nr.
16	2	30	712.113
20	2	30	712.112
	2	32	712.110
	2	35	712.106
25	2	20	712.114
	2	30	712.111
	2	32	712.109
	2	35	712.105
25,4	2	32	712.108
30	2	32	712.107
	2	35	712.104
32	2	35	712.103
	2	40	712.102
35	2	40	712.101

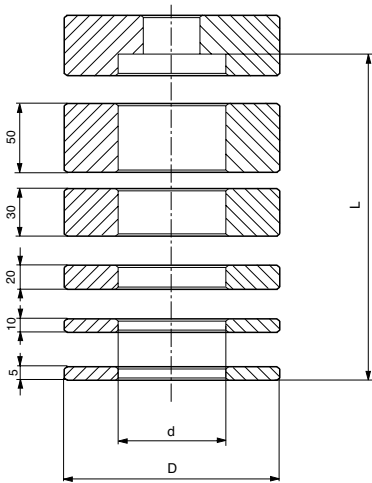
715
Ringsatz für Tischfräsmaschinen
Steel-spacer set for spindle end
PG
02
Stahl-Reduzierring
Steel-spacer set

d	D	L	Art. Nr.
30	43	200	715.300
35	48	200	715.350
40	54	200	715.400
45	62	245	715.450
50	65	245	715.500

Ring Satz
Spacer set

L=200	2x5; 2x10; 3x20; 2x30; 1x50
L=245	3x5; 2x10; 1x20; 3x30; 2x50

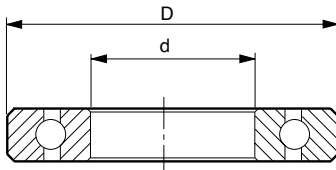
701
Kugellager
Ball bearing
PG
02
Kugellager
Ball bearing

D	d	Art. Nr.
9,5	3,1	701.051
9,5	4,7	701.052
12,7	4,7	701.053
19	6	701.054
22	8	701.055
55	30	701.101
62	35	701.102
68	40	701.103
75	45	701.104
80	50	701.105
69	31	701.106



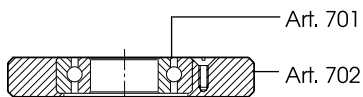
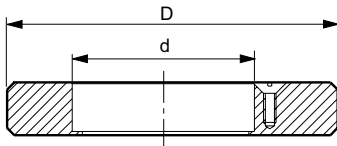

Anlaufring
Template ring

d	B	D	Art. Nr.
55	15,5	70	702.101
	15,5	75	702.106
	15,5	80	702.105
	15,5	85	702.107
	15,5	86	702.104
	15,5	90	702.108
	15,5	94	702.102
	15,5	95	702.109
	15,5	100	702.110
	15,5	105	702.111
	15,5	110	702.112
	15,5	115	702.113
	15,5	120	702.103
	15,5	125	702.115
	15,5	130	702.116
	15,5	135	702.117
	15,5	140	702.118
62	16,5	75	702.145
	16,5	78	702.146
	16,5	80	702.147
	16,5	85	702.148
	16,5	90	702.149
	16,5	95	702.150
	16,5	100	702.151
	16,5	105	702.152
	16,5	110	702.153
	16,5	115	702.154
	16,5	120	702.155
	16,5	125	702.156
	16,5	130	702.157
	16,5	135	702.158
	16,5	140	702.159
68	17,5	75	702.170
	17,5	80	702.171
	17,5	85	702.172
	17,5	90	702.173
	17,5	95	702.174
	17,5	100	702.175
	17,5	105	702.176
	17,5	110	702.177
	17,5	115	702.178
	17,5	120	702.179
	17,5	125	702.180
	17,5	130	702.181
	17,5	135	702.182
	17,5	140	702.183

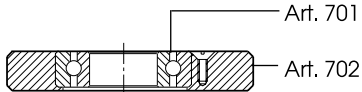
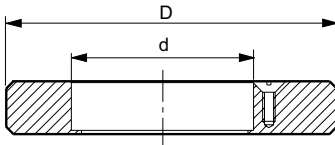
- Fortsetzung nächste Seite
- *Continued next page*

Anlauftring
Template ring

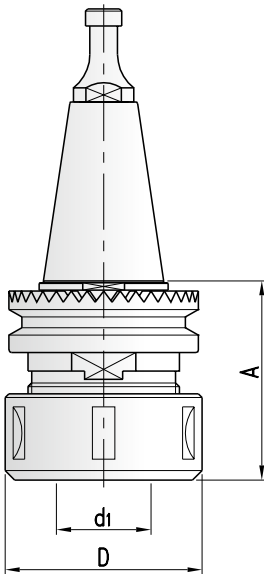
d	B	D	Art. Nr.
69,85	16,5	80	702.125
	16,5	85	702.126
	16,5	90	702.127
	16,5	95	702.128
	16,5	100	702.129
	16,5	105	702.130
	16,5	110	702.131
	16,5	115	702.132
	16,5	120	702.133
	16,5	125	702.134
	16,5	130	702.135
	16,5	135	702.136
	16,5	140	702.137
75	18,5	90	702.190
	18,5	95	702.191
	18,5	100	702.192
	18,5	105	702.193
	18,5	110	702.194
	18,5	115	702.195
	18,5	120	702.196
	18,5	125	702.197
	18,5	130	702.198
	18,5	135	702.199
	18,5	140	702.200
80	18,5	90	702.210
	18,5	95	702.211
	18,5	100	702.212
	18,5	104	702.221
	18,5	105	702.213
	18,5	110	702.214
	18,5	115	702.215
	18,5	120	702.216
	18,5	125	702.217
	18,5	130	702.218
	18,5	135	702.219
	18,5	140	702.220
	18,5	114	702.222
	18,5	109,5	702.224



- Für Links- und Rechtslauf
- For RH and LH rotation

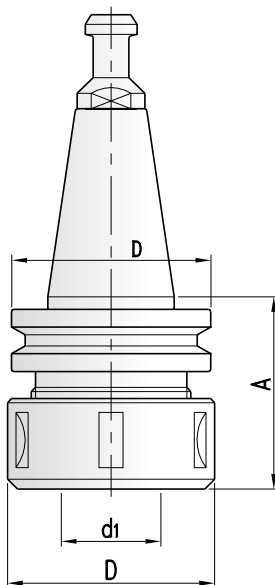

- Für Links- und Rechtslauf
- For RH and LH rotation

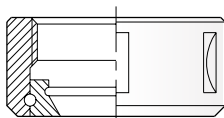

- Kugelgelagerte Spannmutter
- Collet nut with ball bearing

ISO 30 - Spannzangenfutter mit Spannmutter
ISO 30 - Collet chuck with collet nut

S	Nr.	D	A	d1	Art. Nr.
SCM, Morbidelli, verzahnt					
ISO 30	6	50	55	6-20 (ER32)	86.055.230
	6	60	72	6-25 (462E)	86.072.230

Zubehör
Attachment

	D	Dim.	Art. Nr.
Spannmutter - Collet nut	50	M40x1,5	88.470.050
	60	M48x2	88.462.060
Schlüssel - Wrench	50	45/50	706.504
	60	58/62	706.503

SK-Spannzangenfutter mit Spannmutter
SK-Collet chuck with collet nut

S	Nr.	D	A	d1	Art. Nr.
IMA, Maka, Reichenbacher, Biesse, Alberti, Stiegherr., etc.					
SK30	1	50	63	6-20 (ER32)	86.163.030
	1	63	63	6-25 (ER40)	86.063.030
SK40	2	60	70	6-25 (462E)	86.070.060
Biesse (bis • until 9/92)					
SK30	3	50	63	6-20 (ER32)	86.163.130
	3	63	63	6-25 (ER40)	86.063.130
Biesse (nach • after 9/92, spindle HSD)					
SK30	4	50	63	6-20 (ER32)	86.163.230
	4	63	63	6-25 (ER40)	86.063.230
Alberti					
SK30	5	50	63	6-20 (ER32)	86.063.330
	5	63	63	6-25 (ER40)	86.163.330
Masterwood (bis • until 1/99, spindle HSD)					
SK30	4	50	63	6-20 (ER32)	86.163.231
Masterwood (nach • after 1/99, spindle Colombo)					
SK30	5	63	63	6-25 (ER40)	86.163.331
CMS					
ISO 30	8	50	46	6-20 (ER32)	86.046.130
	8	63	70	6-25 (ER40)	86.060.130
Heian					
BT35	7	60	70	6-25 (ER40)	86.070.160
Esseteam (spindle Elite), Stemm					
SK30	9	50	60	6-20 (ER32)	86.060.050
	9	63	67	6-25 (ER40)	86.067.063

- Anzugsbolzen und Spannmutter beinhaltet
- Holding bolt and collet nut included

Ersatzteile
Spare parts

	D	Dim.	Art. Nr.
Spannmutter - Collet nut	50	M40x1,5	88.470.050
	60	M48x2	88.462.060
	63	M50x1,5	88.472.063
Schlüssel - Wrench	50	45/50	706.504
	60	58/62	706.503

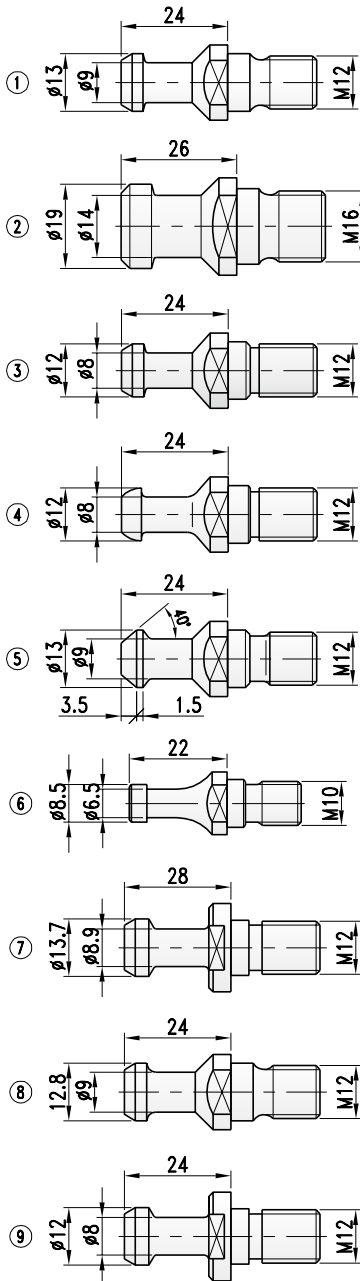
Anzugsbolzen
Holding bolts

Nr.	S	Maschine.	Art. Nr.
1	SK30	IMA, Maka, Reichenbacher, Weeke, etc. (DIN 69872)	3972.000.001
2	SK40	IMA, Maka, Reichenbacher, Weeke, etc. (DIN 69872)	3972.000.002
3	SK30	Biesse (bis • until 9/92)	3972.000.003
4	SK30	Biesse (nach • after 9/92), Masterwood (motor HSD)	3972.000.004
5	SK30	Alberti, Masterwood (motor Colombo)	3972.000.005
6	ISO30	SCM, Morbidelli	3972.000.006
7	BT35	Heian, Shoda	3972.000.007
8	ISO30	CMS	3972.000.008
9	SK30	Stemm, Esseteam (motor Elfe)	3972.000.009

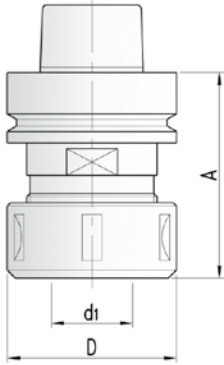
HSK-Spannzangenfutter mit Spannmutter
HSK-Collet chuck with collet nut

A	D	d1	HSK/SpZ	Art. Nr.
76	63	2-26	HSK63E/472E	84.018.070.063
70	50	2-20	HSK63E/470E	84.018.170.063
70	43	2-16	HSK63E/430E	84.018.100.063
76	60	2-25	HSK63E/462E	84.018.176.063
76	63	2-26	HSK63F/472E	84.018.276.063
70	50	2-20	HSK63F/470E	84.018.370.063
70	43	2-16	HSK63F/430E	84.018.470.063
76	60	2-25	HSK63F/462E	84.018.075.063
76	60	2-25	HSK63F/462E	84.009.075.063
115	60	2-25	HSK63F/462E	84.009.115.063
115	60	2-25	HSK63F/462E	84.018.115.063
76	60	2-25	HSK63F/462E	84.018.075.050
115	60	2-25	HSK63F/462E	84.018.115.050
60	50	2-20	HSK40E/470E	84.018.060.050
65	63	2-25	HSK50E/472E	84.018.065.063

- Lieferung ohne Spannzange
- *Collet not included*

Ersatzteile
Spare parts

	D	Dim.	Art. Nr.
Spannmutter - <i>Collet nut</i>	35	M30x1,0	88.430.035
	50	M40x1,5	88.470.050
	60	M48x2	88.462.060
	63	M50x1,5	88.472.063
Schlüssel - <i>Wrench</i>	50	45/50	706.504
	60	58/62	706.503

- Kugelgelagerte Spannmutter
- Weitere Abmessungen, siehe ProLock Spanntechnik Prospekt
- *Collet not included*
- *Further dimension, see ProLock tool clamping systems brochure*

HSK 50E/40

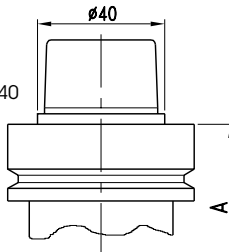

- Für Links- und Rechtslauf
- *For RH and LH rotation*

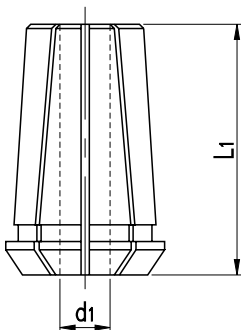

- Weitere Größen auf Anfrage
- *Further dimensions on inquiry*

Spannzangen DIN 6388/462E
Collets DIN 6388/462E

d1	L1	Typ	Art. Nr.
2	52	DIN 6388 / 462E / OZ	87.462.02
3			87.462.03
4			87.462.04
5			87.462.05
6			87.462.06
8			87.462.08
10			87.462.10
12			87.462.12
14			87.462.14
16			87.462.16
18			87.462.18
20			87.462.20
25			87.462.25

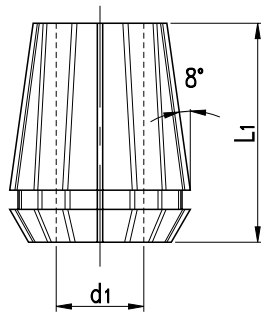

- Weitere Größen auf Anfrage
- Further dimensions on inquiry

ER-Spannzangen
ER-collets

d1	D	L1	Typ	Art. Nr.
bis 12 mm - up to 12 mm				
2	21	31	DIN 6499 / 428E / ER20	87.428.02
3				87.428.03
4				87.428.04
5				87.428.05
6				87.428.06
8				87.428.08
10				87.428.10
12				87.428.12
bis 16 mm - up to 16 mm				
2	26	34	DIN 6499 / 430E / ER25	87.430.02
3				87.430.03
4				87.430.04
5				87.430.05
6				87.430.06
8				87.430.08
10				87.430.10
12				87.430.12
14				87.430.14
16				87.430.16
bis 20 mm - up to 20 mm				
2	33	40	DIN 6499 / 470E / ER32	87.470.02
3				87.470.03
4				87.470.04
5				87.470.05
6				87.470.06
7(6,35)				87.470.07
8				87.470.08
10				87.470.10
12				87.470.12
13(12,7)				87.470.13
14				87.470.14
16				87.470.16
18				87.470.18
20				87.470.20
bis 25 mm - up to 25 mm				
2	41	46	DIN 6499 / 472E / ER40	87.472.02
3				87.472.03
4				87.472.04
5				87.472.05
6				87.472.06
7(6,35)				87.472.07
8				87.472.08
10				87.472.10
12				87.472.12
13(12,7)				87.472.13
14				87.472.14
16				87.472.16
18				87.472.18
20				87.472.20
25				87.472.25

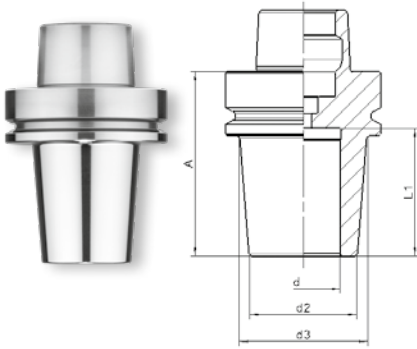

HSK63F-Schrumpffutter
HSK63F-Induction shrink chuck

A	d	d2	S	Art. Nr.
75	6	20	HSK63F	82.006.075.063
	8	20	HSK63F	82.008.075.063
	10	24	HSK63F	82.010.075.063
	12	24	HSK63F	82.012.075.063
	16	27	HSK63F	82.016.075.063
	20	33	HSK63F	82.020.075.063
	25	38	HSK63F	82.025.075.063

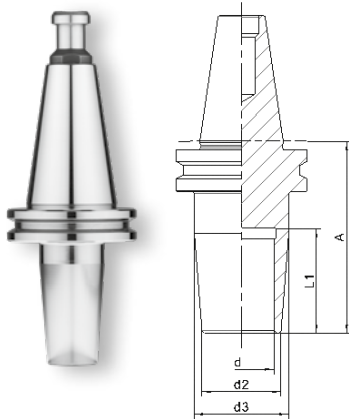
SK30-Schrumpffutter
SK30-Induction shrink chuck

A	d	d2	S	Art. Nr.
70	10	20	SK30	80.010.070.030
70	12	24	SK30	80.012.070.030
70	14	27	SK30	80.014.070.030
70	16	27	SK30	80.016.070.030
70	20	33	SK30	80.020.070.030
70	25	44	SK30	80.025.070.030

SK40-Schrumpffutter
SK40-Induction shrink chucks

A	d	d2	S	Art. Nr.
80	6	20	SK40	81.006.080.040
80	8	20	SK40	81.008.080.040
80	10	24	SK40	81.010.080.040
80	12	24	SK40	81.012.080.040
80	16	27	SK40	81.016.080.040
80	20	33	SK40	81.020.080.040
80	25	44	SK40	81.025.080.040

Schrumpfverlängerung - zylindrisch
shrink fit extension - cylindrical

D	d	d2	A	L2	Art. Nr.
20	3	10	150	- 12	80.030.150.20
20	4	10	150	- 16	80.040.150.20
20	5	10	150	- 20	80.050.150.20
20	6	10	150	10 26	80.060.150.20
20	8	12	150	10 26	80.080.150.20
20	10	14	150	10 32	80.100.150.20
20	12	16	150	10 37	80.120.150.20
25	8	20	150	10 26	80.080.150.25
25	10	20	150	10 32	80.100.150.25
25	12	20	150	10 37	80.120.150.25
25	14	20	150	10 37	80.140.150.25
25	16	22	150	10 40	80.160.150.25

Der Einsatz eines Induktions-Schrumpfgerätes ermöglicht das Ein- und Ausschumpfen von Hartmetall- und Stahlschäften in die entsprechenden Schrumpffutter. Vorteile sind die höchste Rundlaufgenauigkeit (max. 0,003mm), die schlanke Störkontur, höchste Haltekraft und die direkte formstabile Einspannung. Für Rechts- und Linkslauf geeignet.

Using an induction shrink system enables the shrinking of carbide- and steel-shanks in the corresponding induction shrink chucks. Advantages are the highest concentricity precision (max. 0,003mm), the slim interference contour, the maximum of gripping force and the direct dimensionally stable clamping. Suitable for right- and left-hand rotation.

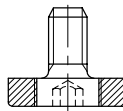
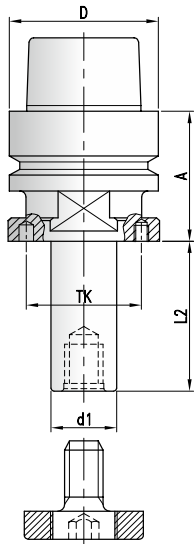
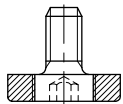
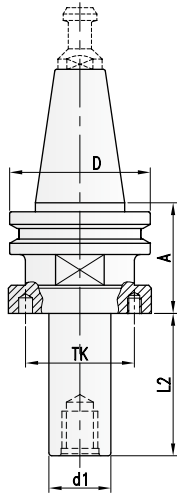
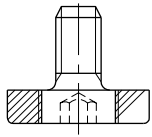
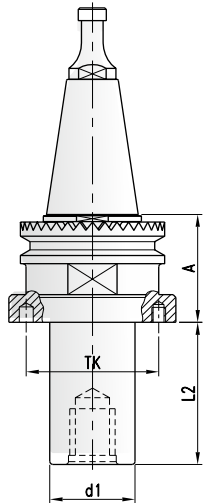
ISO30-Fräsdorn
ISO30-Arbor

d1	L2	A	TK	S	D	Nr.	Art. Nr.
SCM, Morbidelli, verzahnt							
20	40	45	38	ISO30		6	47.020.340.030
	70	45		ISO30		6	47.020.370.030
30	40	45	48	ISO30		6	47.030.340.030
	80	45		ISO30		6	47.030.380.030
CMS							
20	40	42	38	ISO30	46	8	47.020.440.030
	70					8	47.020.470.030
30	40	42	48	ISO30	46	8	47.030.440.030
	80					8	47.030.480.030

- Lieferung ohne Distanzringe und Anzugsbolzen
- Supplied without spacers and holding holding bolt.

SK-Fräsdorn
SK-Arbor

d1	L2	A	TK	S	Art. Nr.
IMA, Maka, Reichenbacher, Weeke, Biesse, Alberti, Stegherr, etc.					
20	40	42	38	SK30	47.020.240.030
	70				47.020.270.030
20	40	42	38	SK40	47.020.240.040
	70				47.020.270.040
30	40	42	48	SK30	47.020.140.030
	80				47.030.080.030
30	40	42	48	SK40	47.030.140.040
	80				47.030.180.040

- Lieferung ohne Distanzringe und Anzugsbolzen
- Supplied without spacers and holding holding bolt.

HSK-Fräsdorn
HSK-arbor

d1	L2	A	TK	S	D	Art. Nr.
20	70	45	38	HSK 63F	63	47.020.070.163
30	20	45	48	HSK 63F	63	47.030.020.063
	40	45		HSK 63F	63	47.030.040.263
	55	45		HSK 63F	63	47.030.056.063
	80	45		HSK 63F	63	47.030.080.163
	100	45		HSK 63F	63	47.030.100.063

Lange Ausführung • Long design

20	40	80	38	HSK 63F	63	47.020.040.063
	70	80		HSK 63F	63	47.020.070.063
30	20	75	48	HSK 63F	63	47.030.020.163
	40	75		HSK 63F	63	47.030.040.463
	55	75		HSK 63F	63	47.030.055.163
	80	75		HSK 63F	63	47.030.080.263
	100	75		HSK 63F	63	47.030.100.163
	80	80		HSK 63F	63	47.030.080.363

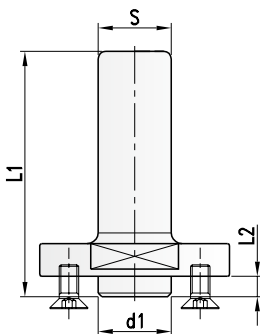
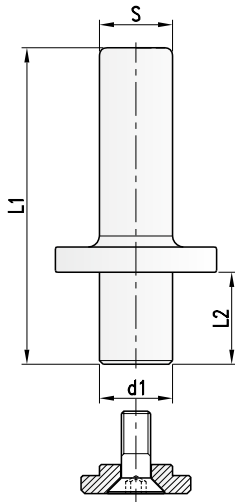
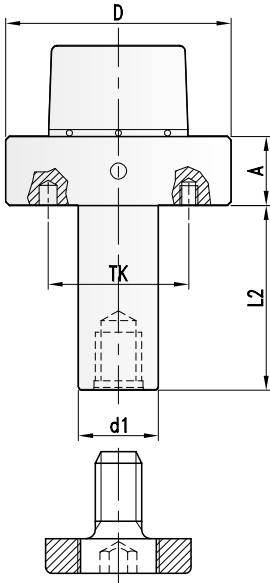

- Für Lamello-Nuter mit Bohrung 22
- For direct mounting of tools, d1=22 for grooving cutter "LAMELLO"

HSK-Fräsdorn für automatischen Werkzeugwechsel - beidseitiger Passfeder
HSK-milling arbor for automatic tool change - with both-sided feather key to lock against rotation

d1	L2	ML	A	S	Art. Nr.		
30	40	2/6/48+2/M6/48	26	HSK85WS	85	47.030.040.085	
	60	2/6/48+2/M6/48	26			47.030.060.085	
	80	2/6/48+2/M6/48	26			47.030.080.085	
	130	2/6/48+2/M6/48	26			47.030.130.085	
	170	2/6/48+2/M6/48	26			47.030.170.185	
35	180	2/6/54+2/M6/54	26	HSK85WS	85	47.035.180.085	
	240	2/6/54+2/M6/54	26			47.030.240.085	
40	40	2/6/54+2/M6/54	26	HSK85WS	85	47.040.040.085	
	60	2/6/54+2/M6/54	26			47.040.060.085	
	80	2/6/54+2/M6/54	26			47.040.080.085	
	100	2/6/54+2/M6/54	26			47.040.100.085	
	130	2/6/54+2/M6/54	26			47.040.130.085	
	170	2/6/54+2/M6/54	26			47.040.170.185	
	180	2/6/54+2/M6/54	26			47.040.180.085	
	210	2/6/54+2/M6/54	26			47.040.210.185	
	240	2/6/54+2/M6/54	26			47.040.240.085	
	50	40	2/6/64+2/M6/64	26	HSK85WS	85	47.050.040.085
		60	2/6/64+2/M6/64	26			47.050.060.085
		80	2/6/64+2/M6/64	26			47.050.080.085
100		2/6/64+2/M6/64	26			47.050.100.085	
130		2/6/64+2/M6/64	26			47.050.130.085	
150		2/6/64+2/M6/64	26			47.050.150.085	
170		2/6/64+2/M6/64	26			47.050.170.085	
180		2/6/64+2/M6/64	26			47.050.180.085	
240		2/6/64+2/M6/64	26			47.050.240.085	
270		2/6/64+2/M6/64	26			47.050.270.085	

- Für Weinig "PowerMat" Kehlmaschinen
- For Weinig "PowerMat" moulding machines

Fräsdorn mit zyl. Schaft
Arbor with zyl. shank

d1	L2	L1	S	Art. Nr.
20	40	98	20x50	495.020.040
	40	108	25x60	495.020.240
20	70	128	20x50	495.020.070
	70	138	25x60	495.020.170
30	40	98	20x50	495.030.040
		108	25x60	495.030.240

Fräsdorn für Sägen und Nuter
Arbor for saws and groovers

d1	L2	L1	S	Art. Nr.	
22	4	69	36	25x60	495.022.004
30	4	69	48	25x60	495.030.004

Zubehör
Attachment

Dim.	Art. Nr.	
Schraube - Screw	M6x16 (DIN7991)	705.350
Sechskantschlüssel - T Wrench	SW3	706.103

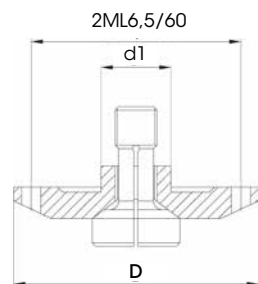
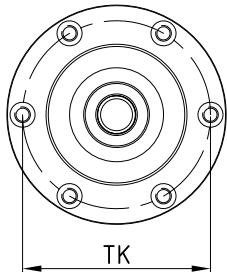
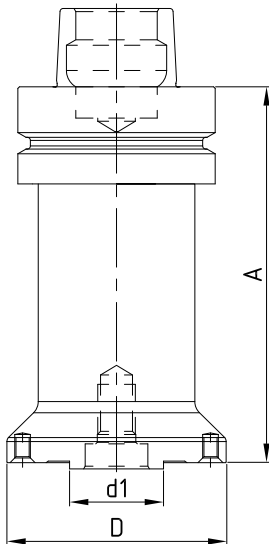

- Weitere Größen auf Anfrage
- Further dimensions on inquiry

HSK Sägeblattaufnahme Monoblock
 HSK Sawarbor monobloc

d1	D	A	TK/ML	S	Art. Nr.
30/20	70	45	6/M5/60	HSK63F	47.300
	70	110	6/M5/60	HSK63F	47.400
	70	150	6/M5/60	HSK63F	47.500
30/20	160	40	8/M5/90	HSK63F	① 47.106.010
	160	50	8/M5/90	HSK63F	① 47.106.014
30/20	70	45	6/M5/60	HSK63E	47.350
	70	110	6/M5/60	HSK63E	47.450
	70	150	6/M5/60	HSK63E	47.550

- ① Sägeblattaufnahme Homag Drive 5c/+
- ① Sawarbor for Homag Drive 5c/+

- Auslieferung erfolgt mit 6 Senkkopfschrauben für Sägenbefestigung / "über Mitte Schnitt"
- Supplied with 6 counter-sunk screws for sawmounting / center cut

Gegenflansch für Sägenaufnahme
 Counterflange for sawarbor

d1	D	TK/ML	Typ	Art. Nr.
20	70	2/6,5/60	Schraube DIN912 SW=10	36.070.010
	70	2/6,5/60	EF-Schnellwechsel Typ 3/4 M12 Sw=3	36.070.020
	106	8/5,5/90		34.106.020

- Art. 36.070.010 Gegenflansch mit Standard Schraube DIN912
- Art. 36.070.020 Gegenflansch mit EF-Einschraubspanner für Sägenschnellwechsel
- Art. 36.070.010 Counterflange with standard screw DIN912
- Art. 36.070.020 Counterflange with EF-Screw-in clamp for quickchange of blades



Zur Reinigung von Spindelnasen, Adaptern und Vorsatzflanschen
For cleaning spindle noses, adapters and extension flanges

D	HSK	Art. Nr.
63	HSK63F	91.063.050
63	HSK63E	91.063.063
80	HSK80WS	91.080.063
80	HSK80E	91.080.080

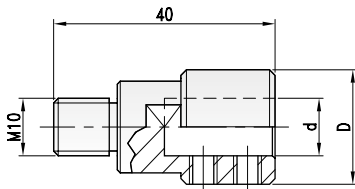

M10 - ohne Passsitz
M10 - without seating

D	d	Art. Nr. RH	Art. Nr. LH
Ayen, Holzma, Mayer, Knoevenagel, Torwegge, etc.			
20	10	478.020.010	478.020.110

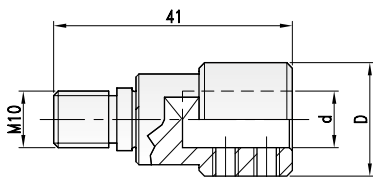

M10 - mit Passsitz 11
M10 - with seating 11

D	d	Art. Nr. RH	Art. Nr. LH
Morbidelli, Weeke, Torwegge, Biesse, Masterwood, Vitap, etc.			
20	10	478.020.210	478.020.310

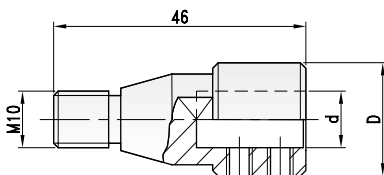

M8 - mit Passsitz 9
M8 - with seating 9

D	d	Art. Nr. RH	Art. Nr. LH
Biesse, SCM, CMS, Morbidelli, etc.			
20	10	478.020.410	478.020.510

M10 - mit Kegel
M10 - with cone

D	d	Art. Nr. RH	Art. Nr. LH
Bilek, Vitap, Alberti, Balestrini, Schleicher, Busellato, etc.			
20	10	478.020.610	478.020.710

Zubehör
Attachment

	Dim	Art. Nr.
Verstellschraube - Screw	M5x5	705.102
Sechskantschlüssel - Wrench	SW2,5	706.152

611

SSA-Selbstspannaufnahme SSA-Quick-change-adapter

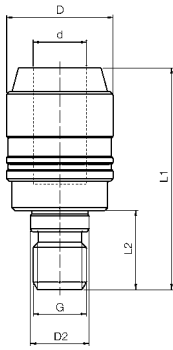

Spannfläche am Bohrer
Clamping surface on drill



Für Schäfte Ø10 mit Spannfläche
For shank Ø10 and machined flat

PG
02

D1	d	L2	L1	D2	G Rotation	Art. Nr.
20	10	15	42	9	M8RH	611.010.008
20	10	15	42	9	M8LH	611.010.108
20	10	18	45	10	RH	611.010.018
20	10	18	45	10	LH	611.010.118
20	10	15	42	11	M10RH	611.010.010
20	10	15	42	11	M10LH	611.010.110

- Schnellwechselsystem für Dübelbohrer mit Schaft Ø 10mm und Spannfläche.
- Schiebehülse zurückschieben. Bohrer einstecken.
- Schubhülse spannt automatisch, wenn Schaftspannfläche auf Spankeil gedreht wird.
- *Quickchange for dowel drills with shank 10mm and machined flat.*
- *Push down the bushing and insert the tool shank up to the stop.*
- *By turning the toolshaft, the mechanism clamps the toolshank automatically.*

Ersatzteile / Zubehör

Spare parts / Accessories

PG
01

Art. Nr.	
Bohrfutter-Montageschlüssel d=10 - Holder mounting key	611.107.010
Bohrfutter-Verschlusskappe d=10 - Holder mounting cap	611.115.010
Einstellschraube M5x10 - Adjusting screw	705.103

474

Schnell-Wechsel-Adapter Quick-change-adapter

PG
02

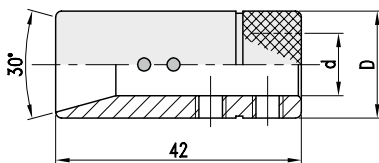

Schnellwechsel-Adapter
Quick-change adapter

D	d	Art. Nr.
Vitap		
18	10	474.018.010

Zubehör

Attachment

Dim.	Art. Nr.
Verstellschraube - Screw	M5x4 705.102.04
Sechskantschlüssel - Wrench	SW2,5 706.152

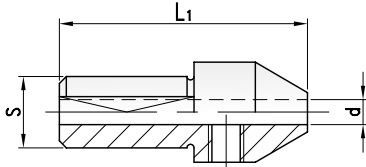
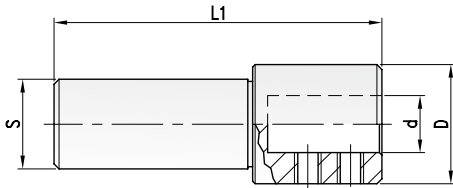

Reduzierungen
Reducers

D	d	S	Art. Nr.
20	6	18	495.020.006
20	8	18	495.020.008
22	10	18	495.022.010
22	12	18	495.022.012

Reduzierungen
Reducers

d	L1	S	Art. Nr.
2,0	38	10	495.002.038
2,5	38	10	495.003.038
3,0	38	10	495.003.138
3,5	38	10	495.004.038
4,0	38	10	495.004.138
4,5	38	10	495.005.038
5,0	38	10	495.005.138

Zubehör
Attachment

	Dim.	Art. Nr.
Verstellschraube - <i>Screw</i>	M5x5	705.102
Sechskantschlüssel - <i>Wrench</i>	SW2,5	706.152

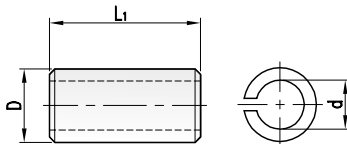

Reduzierungen
Reducers

d	L1	D	Art. Nr.
6	25	8	494.006.025
8	25	10	494.008.025
6	25	12	494.006.125
8	25		494.008.125
10	25		494.010.025

Reduzierungen
Reducers

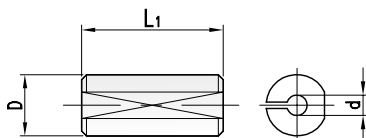
d	L1	D	Art. Nr.
2,0	23	10	494.002.023
2,5	23	10	494.003.023
3,0	23	10	494.003.123
3,5	23	10	494.004.023
4,0	23	10	494.004.123
4,5	23	10	494.005.023
5,0	23	10	494.005.123
6,0	23	10	494.006.023
7,0	23	10	494.007.023
8,0	23	10	493.008.023

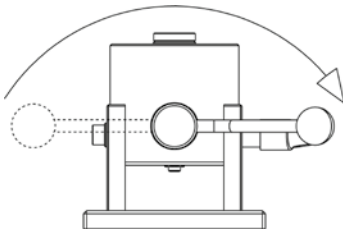

HSK-Montagevorrichtung
Mounting device for HSK

HSK	L	H	D	Art. Nr.
HSK32	100	87,5	40	38.032.035
HSK40	100	87,5	40	38.040.035
HSK63F	100	110	63	38.063.050
HSK63	100	110	63	38.063.063
HSK80WS (Weinig - PowerLock)	100	110	85	38.085.063
HSK80	200	140	100	38.080.080
HSK100	200	200	125	38.100.100

- Praktische, schwenkbare Montagevorrichtung. Werkzeugloses Einspannen bzw. Lösen der HSK-Werkzeuge durch leicht bedienbaren Drehgriff.
- *Practical, swivellable HSK-mounting device. Toolless clamping or releasing of the HSK-tool by easily operable rotary handle.*

- 01 Sägen
- 02 Hobeln / Fräsen
- 03 Hobeln / Fräsen
- 04 Profi fräsen
- 05 Nut- und Federfräsen
- 06 Oberfräsen
- 07 Bohren
- 08 PKD-Werkzeuge
- 09 Spannen
- 10 Ersatzteile
- 11 Informationen

Montagevorrichtung für BT/ISO/SK
Mounting device for BT/ISO/SK

BT/ISO/SK	D	Art. Nr.
ISO30, BT30	46	438.030.046
SK30, HSK50, C5	50	438.030.050
BT35	53	438.035.053
SK40/HSK63, BT40, C6	63	438.040.063
HSK80WS	85	438.080.085
HSK100, BT50	102	438.050.100
SK50	97,5	438.050.098

- Montagevorrichtung mit Rollen zum sicheren Klemmen von Werkzeugaufnahmen. Selbstklemmend und passend zu SK, ISO, HSK, BT und Capto-Aufnahmen.
- *Mounting device for draw-in collet chuck and arbors ISO/SK by simple exchanging of the clamping jaw.*

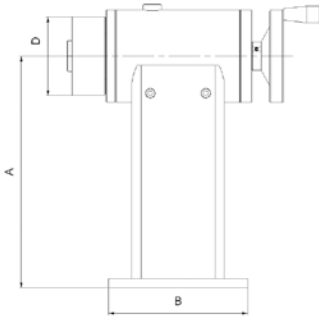
Montagestand für HSK85WS Werkzeuge
Assembly spindle for HSK tools

HSK	A	D	B	Art. Nr.
HSK85WS-Messspindel	250	85	150	835.250.015

- Montagestand für HSK85WS Werkzeuge. Gelagerte HSK85WS Spindel mit Spannsystem. Verwendung z.B. zum Vermessen des Rundlaufs (über zusätzliche Messvorrichtung) oder Montage bzw. Demontage von Messern oder Fräsern.
- *Assembly stand for HSK85WS tools. Turnable ball bearing spindle with clamping system. For setting of HSK85WS tools, mounting of knives or cutters, or to measure runout (with additional device).*





01



02



03



04



05



06



07



08



09



10



11



