

ProChipper®



tooling systems



Fräswerkzeuge mit Bohrung, profiliert
Tools with bore, profiled

8214

HW Fase- Abrund- Fügefräsergarnitur, verstellbar - Festbestückt

TC Jointing- bevelling- rounding cutterset, adjustable - Tipped

PG
02

zum Fügen, Fasen bzw. Abrunden variabler Holzstärke
for jointing andprofiling a bevel or round edge on top and bottom

MEC

HW

| Nr. | D | B | d | Z | R | n. max | Art. Nr. |
|-------|-----|----|-------|---|---|--------|---------------------|
| 1 | 140 | 60 | 30/50 | 3 | | 8500 | 8214.140.060 |
| 2 | 153 | 18 | 30/50 | 3 | 5 | 8500 | 8214.153.018 |
| 3 | 153 | 18 | 30/50 | 3 | 5 | 8500 | 8214.153.118 |
| 1+2+3 | | | 30/50 | 3 | | 8500 | 8214.000.000 |

- HW-Bestückte Füge, Fase- oder Abrund- Fräser. Kombinations-Werkzeuge zum Fügen, Fasen bzw. Abrunden variabler Holzstärken für mechanischen Vorschub
- TC-Tipped Jointing, bevelling- or rounding- cutter. Combination-tools for jointing and profiling a bevel or round edge on top and bottom for mechanical feed

Ersatzteile
Spare parts

| B | Art. Nr. |
|-------------------------------|----------------|
| Zwischenringsatz - Spacer set | 703.015 |

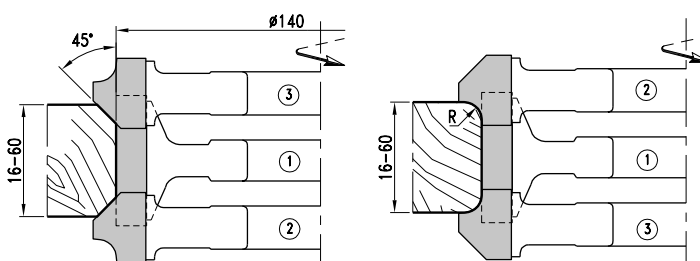

- Einstellung der Holzstärke mit Zwischenringen. Einstellbar von 16mm - 60mm Holzstärke
- Adjustment of wood-thickness with spacers. Adjustable from 16mm - 60mm wood-thickness

8284

HW Abrund- und Fügefräsergarnitur verstellbar - Festbestückt

TC Jointing- rounding cutterset, adjustable - Tipped

PG
02

Zum Fasen bzw. Abrunden variabler Holzstärken
For jointing and profiling a bevel or round edge on top and bottom

MEC

HW

| Nr. | D | d | Z | R | n. max | Art. Nr. |
|-----|-----|----|---|---|--------|---------------------|
| 1 | 140 | 50 | 4 | 3 | 9500 | 8284.140.003 |
| 1 | 140 | 50 | 4 | 5 | 9500 | 8284.140.005 |
| 1 | 140 | 50 | 4 | 8 | 9500 | 8284.140.008 |
| 2 | 140 | 50 | 4 | 3 | 9500 | 8284.140.103 |
| 2 | 140 | 50 | 4 | 5 | 9500 | 8284.140.105 |
| 2 | 140 | 50 | 4 | 8 | 9500 | 8284.140.108 |

- HW-Bestückte Füge- Abrund- Fräser. Kombinations-Werkzeuge zum Fasen bzw. Abrunden variabler Holzstärken für mechanischen Vorschub
- Einstellung der Holzstärke mit Zwischenringen. Einstellbar von 14mm - 45mm Holzstärke
- TC-Tipped Jointing- rounding- cutter. Combination-tools for jointing and profiling a bevel or round edge on top and bottom for mechanical feed
- Adjustment of wood-thickness with spacers. Adjustable from 14mm - 45mm wood-thickness

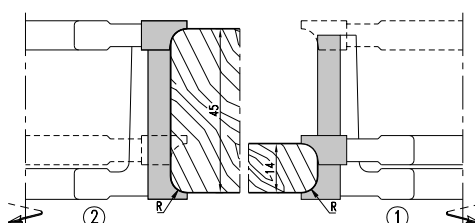

3111

HS/HW Hydro Profilfräser - Festbestückt

HS/TC Hydro Profile cutter - Tipped

PG
02

Riffel-Profilbeispiel am Hydrofräser

Example of a profiled hydro cutter

MEC

- Hydro-Profilhobelwerkzeuge mit hochgenauer zentrischer Hydrospannung für erhöhte Rundlaufgenauigkeit. Profilierung der festbestückten Hydroausführung mit Schneiden aus HSS bzw. HM nach Kundenwunsch. Diese Werkzeugsysteme führen zu einem gleichmäßigen, fast messerschlagfreiem Hobelbild. Möglichkeit der engen Verzahnung durch festbestückte Ausführung, führt zu erhöhter Produktivität bei großen Vorschubgeschwindigkeiten
- *Hydro-Profileplanerheads with highly accurate concentric clamping gives finishes almost free from cuttermarks. Profiling of tipped hydrocutters with HSS- or HM-knives on costumers request. The design of this tipped tool systems provide an opportunity for a high number of tips.*

4869

HW Füge- Fase- Radienfräser, verstellbar - Wendemesser

TC Jointing, bevelling- and rounding cutterset, adjustable - Reversible knife

PG
02

Auslieferung mit Kantenrunder R=3

Cutterheads supplied with rounding blade R=3

MAN

HW

| D | B | d | Z | C | n. min-max | Art. Nr. |
|-----|----|-------|---|---|------------|--------------|
| 125 | 50 | 40/50 | 4 | 4 | 6200-12600 | 4869.125.050 |

- Fasefräser für Handvorschub. WP-Fase- oder Abrundfräser. Werkzeug zum Fügen, Fasen bzw. Abrunden variabler Holzstärken für manuellen Vorschub.
- Die Einstellung der zu rundenden bzw. anzufasenden Holzstärke erfolgt über an Skala verschiebbaren Messerträgern. Einstellbar von 12mm - 50mm Holzstärke
- *Bevelling cutter with reversible knives for manual feed. TC- bevelling- or rounding- cutter with reversible knives. Tool for jointing and profiling a bevel or round edge on top and bottom for manual feed*
- *Adjustment of wood-thickness with knife-holder on lasermarked scale. For wood-thickness from 12mm to 50mm*

Wendemesser/Ersatzteile

Reversible knives/Spare parts

| | Dim. | Art. Nr. |
|------------------------------------|------------|------------|
| Zwischenringsatz - Spacer set | 50x12x1,5 | 750.106 |
| Spannkeil - Clamping wedge | | 707.002.48 |
| Gewindestift - Screw | M8x16 | 705.542 |
| Fasenmesser - Chamfering knife | 45° | 780.260 |
| Kantenrunder - Edge rounding knife | R=2 | 780.250 |
| Kantenrunder - Edge rounding knife | R=3 | 780.251 |
| Spannschraube - Screw | M5x13,5 | 705.318 |
| Gewindestift - Screw | M5x12 | 705.523 |
| Sechskantschlüssel - T Wrench | SW2,5 (M5) | 706.102 |
| Sechskantschlüssel - T Wrench | SW4 (M8) | 706.104 |

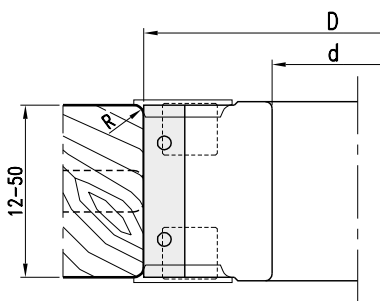
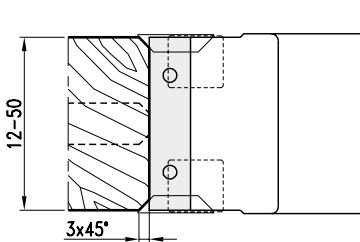

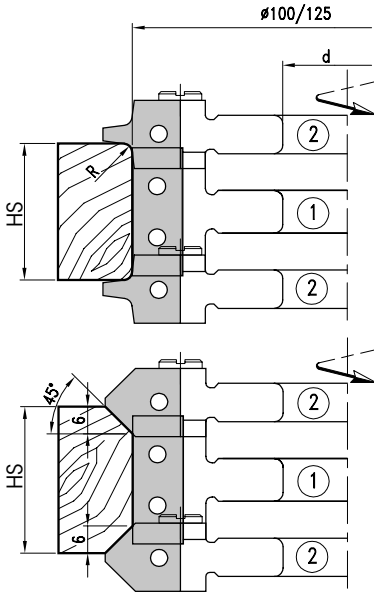

Kombinations-Werkzeuge zum Fasen bzw. Abrunden variabler Holzstärken
Combination-tools for jointing and profiling a bevel or round edge on top and bottom

MEC

HW

| Nr. | D | B | d | Z | R | Art. Nr. |
|-----|-----|----|-------|---|-----------------|-----------------------|
| 1 | 100 | 30 | 30 | 2 | | 5214.100.030 |
| 1 | 100 | 50 | 30 | 2 | | 5214.100.050 |
| 1 | 125 | 30 | 40/50 | 3 | | 5214.125.030 |
| 1 | 125 | 50 | 40/50 | 3 | | 5214.125.050 |
| 2 | 113 | 16 | 30 | 2 | 2,3,4,5,6 / 45° | ① 5214.113.016 |
| 2 | 137 | 16 | 40/50 | 3 | 2,3,4,5,6 / 45° | ① 5214.137.016 |
| 2 | 146 | 25 | 40/50 | 3 | 8,10 / 45° | ① 5214.146.025 |

① Ohne Wendemesser. Bitte Wendemesser und Zwischenringsätze mitbestellen

① Cutterheads without knives. Please order reversible knives and spacer sets additional

Wendemesser/Ersatzteile
Reversible knives/Spare parts

| | Dim. | R | Art. Nr. |
|--------------------------------|-----------|----------------|-------------------|
| Wendemesser - Reversible knife | 30x12x1,5 | | 750.104 |
| | 50x12x1,5 | | 750.106 |
| | 16x17,5x2 | R2 | 765.101 |
| | 16x17,5x2 | R3 | 765.102 |
| | 16x17,5x2 | R4 | 765.103 |
| | 16x17,5x2 | R5 | 765.104 |
| | 16x17,5x2 | R6 | 765.105 |
| | 25x25x2 | R8 | 765.107 |
| | 25x25x2 | R10 | 765.109 |
| | 16x17,5x2 | 7x45° | 765.501 |
| 25x25x2 | 10x45° | 765.502 | |
| Spannkeil - Clamping wedge | B30 | | 707.001.28 |
| | B50 | | 707.001.48 |
| | | R2-6 / 45° | 707.155 |
| | | R8-10 / 45° | 707.280 |
| Gewindestift - Screw | M6x10 | R2-6 / 45° | 705.532 |
| | M8x12 | R8-10 / 45° | 705.541 |
| Sechskantschlüssel - T Wrench | SW3 (M6) | | 706.103 |
| | SW4 (M8) | | 706.104 |

| | Nr.1 (B 30) | | Nr.1 (B 50) | |
|-----------|-------------|---------|-------------|---------|
| | HS min-max | 2x(1) | HS min-max | 2x(1) |
| R2-6/45° | 12-39 | 703.009 | 16-60 | 703.015 |
| R8-12/45° | 20-47 | 703.010 | 20-67 | 703.012 |

(1) Verstellbarkeit der Holzstärke, Art. Nr. Zwischenringsatz

(1) Adjustment of wood thickness (HS), Art. Nr. spacer set

| | | |
|-------|-----------|-------------|
| • RPM | D 100-113 | n max 11800 |
| | D 125-137 | n max 9100 |
| | D 125-146 | n max 9100 |

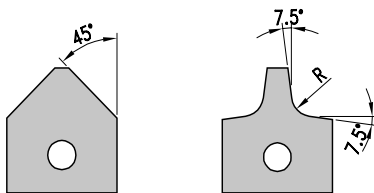

Einstellung der Holzstärke mit Zwischenringen. Einstellbare Holzstärken sind:
Adjustment of wood-thickness with spacers. Adjustable wood-thickness:

| | Holzstärke |
|----------------------------------|------------|
| D100/D113 B30 Z=2 R2-6 bzw. 45° | 12-39 mm |
| D100/D113 B50 Z=2 R2-6 bzw. 45° | 16-60 mm |
| D125/D137 B30 Z=3 R2-6 bzw. 45° | 12-39 mm |
| D125/D137 B50 Z=3 R2-6 bzw. 45° | 16-60 mm |
| D125/D146 B30 Z=3 R8-10 bzw. 45° | 20-47 mm |
| D125/D146 B50 Z=3 R8-10 bzw. 45° | 20-67 mm |

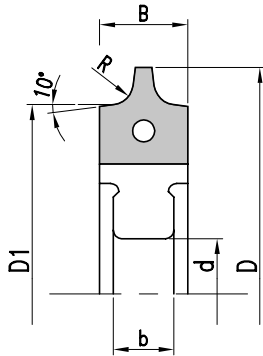

WP-Abrundfräser zum Abrunden der Anleimerkante an Kantenbearbeitungsanlagen
TC-Rounding-cutter with reversible knives. For rounding edge bandings on edge processing units

MEC

HW

| D | D1 | B/d | d | DKN | R | Z | n. max | Art. Nr. |
|-------------------------------|------|-------|----|-------|---|---|--------|---------------------|
| Homag - Gabbiani - Ott | | | | | | | | |
| 73 | 61,0 | 16/11 | 16 | 5x2,3 | 2 | 3 | 18000 | 5114.073.002 |
| 73 | 61,0 | 16/11 | 16 | 5x2,3 | 3 | 3 | 18000 | 5114.073.003 |
| 73 | 61,0 | 16/11 | 16 | 5x2,3 | 4 | 3 | 18000 | 5114.073.004 |
| 73 | 61,0 | 16/11 | 16 | 5x2,3 | 5 | 3 | 18000 | 5114.073.005 |
| HolzHer | | | | | | | | |
| 73 | 61,0 | 16/11 | 20 | 6x3,5 | 2 | 3 | 18000 | 5114.173.002 |
| 73 | 61,0 | 16/11 | 20 | 6x3,5 | 3 | 3 | 18000 | 5114.173.003 |
| 73 | 61,0 | 16/11 | 20 | 6x3,5 | 4 | 3 | 18000 | 5114.173.004 |
| 73 | 61,0 | 16/11 | 20 | 6x3,5 | 5 | 3 | 18000 | 5114.173.005 |
| IDM | | | | | | | | |
| 73,3 | 61,3 | 16/10 | 16 | 5x2,3 | 2 | 3 | 18000 | 5114.273.002 |
| 73,3 | 61,3 | 16/10 | 16 | 5x2,3 | 3 | 3 | 18000 | 5114.273.003 |
| 73,3 | 61,3 | 16/10 | 16 | 5x2,3 | 4 | 3 | 18000 | 5114.273.004 |
| 73,3 | 61,3 | 16/10 | 16 | 5x2,3 | 5 | 3 | 18000 | 5114.273.005 |
| IMA - Wilmsmeyer | | | | | | | | |
| 82 | 70,0 | 16/10 | 20 | 6x3,5 | 2 | 4 | 18000 | 5114.082.002 |
| 82 | 70,0 | 16/10 | 20 | 6x3,5 | 3 | 4 | 18000 | 5114.082.003 |
| 82 | 70,0 | 16/10 | 20 | 6x3,5 | 4 | 4 | 18000 | 5114.082.004 |
| 82 | 70,0 | 16/10 | 20 | 6x3,5 | 5 | 4 | 18000 | 5114.082.005 |

Wendemesser/Ersatzteile

Reversible knives/Spare parts

| | Dim. | R | Art. Nr. |
|--------------------------------|-----------|-----|----------------|
| Wendemesser - Reversible knife | 16x17,5x2 | R 2 | 765.101 |
| Wendemesser - Reversible knife | 16x17,5x2 | R 3 | 765.102 |
| Wendemesser - Reversible knife | 16x17,5x2 | R 4 | 765.103 |
| Wendemesser - Reversible knife | 16x17,5x2 | R 5 | 765.104 |
| Spannkeil - Clamping wedge | | | 707.155 |
| Gewindestift - Screw | M6x12 | | 705.533 |
| Sechskantschlüssel - T Wrench | SW3 | | 706.103 |

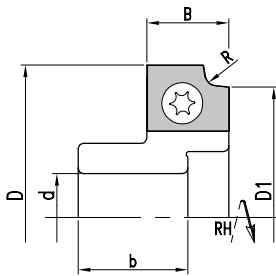
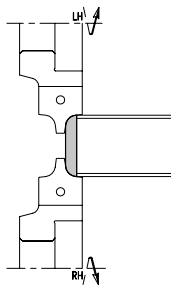
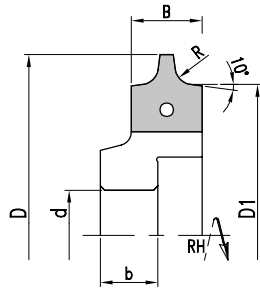

WP-Abrundfräser zum Abrunden der Anleimerkante an Kantenbearbeitungsanlagen
TC- Rounding- cutter with reversible knives. For rounding edge bandings on edge processing units

MEC

HW

| D | D1 | B/d | d | DKN | R | Z | n. max | Art. Nr. RH | Art. Nr. LH |
|------------|----|-------|----|-------|---|---|--------|---------------------|---------------------|
| IMA | | | | | | | | | |
| 82 | 70 | 16/13 | 20 | 6x3,5 | 2 | 4 | 18000 | 5174.082.002 | 5174.082.102 |
| | 70 | 16/13 | 20 | 6x3,5 | 3 | 4 | 18000 | 5174.082.003 | 5174.082.103 |
| | 70 | 16/13 | 20 | 6x3,5 | 4 | 4 | 18000 | 5174.082.004 | 5174.082.104 |
| | 70 | 16/13 | 20 | 6x3,5 | 5 | 4 | 18000 | 5174.082.005 | 5174.082.105 |

Wendemesser/Ersatzteile

Reversible knives/Spare parts

| | Dim. | R | Art. Nr. |
|--------------------------------|-----------|-----|----------------|
| Wendemesser - Reversible knife | 16x17,5x2 | R 2 | 765.101 |
| Wendemesser - Reversible knife | 16x17,5x2 | R 3 | 765.102 |
| Wendemesser - Reversible knife | 16x17,5x2 | R 4 | 765.103 |
| Wendemesser - Reversible knife | 16x17,5x2 | R 5 | 765.104 |
| Spannkeil - Clamping wedge | | | 707.155 |
| Gewindestift - Screw | M6x12 | | 705.533 |
| Sechskantschlüssel - T Wrench | SW3 | | 706.103 |

WP-Abrundfräser zum Abrunden der Anleimerkante an Kantenbearbeitungsanlagen
TC- Rounding- cutter with reversible knives. For rounding edge bandings on edge processing units

MEC

HW

| D | D1 | B/d | d | DKN | R | Z | n. max | Art. Nr. RH | Art. Nr. LH |
|------------|------|-------|----|-------|-----|---|--------|---------------------|---------------------|
| SCM | | | | | | | | | |
| 55,5 | 47,5 | 15/20 | 20 | 6x3,5 | 1,0 | 2 | 18000 | 5174.056.001 | 5174.056.101 |
| | 47,5 | 15/20 | 20 | 6x3,5 | 1,5 | 2 | 18000 | 5174.056.002 | 5174.056.102 |
| | 47,5 | 15/20 | 20 | 6x3,5 | 2,0 | 2 | 18000 | 5174.056.202 | 5174.056.302 |
| | 47,5 | 15/20 | 20 | 6x3,5 | 2,5 | 2 | 18000 | 5174.056.003 | 5174.056.103 |
| | 47,5 | 15/20 | 20 | 6x3,5 | 3,0 | 2 | 18000 | 5174.056.203 | 5174.056.303 |

Wendemesser/Ersatzteile

Reversible knives/Spare parts

| | Dim. | R | Art. Nr. |
|--------------------------------|-----------|-------|----------------|
| Wendemesser - Reversible knife | 15x12x1,5 | R 1,0 | 765.200 |
| Wendemesser - Reversible knife | 15x12x1,5 | R 1,5 | 765.201 |
| Wendemesser - Reversible knife | 15x12x1,5 | R 2,0 | 765.202 |
| Wendemesser - Reversible knife | 15x12x1,5 | R 2,5 | 765.203 |
| Spannkeil - Clamping wedge | 15x12x1,5 | R 3,0 | 765.204 |
| Torx Schrauben - Screw | M3,5x7,5 | | 705.352 |
| Sechskantschlüssel - T Wrench | T15 | | 706.302 |

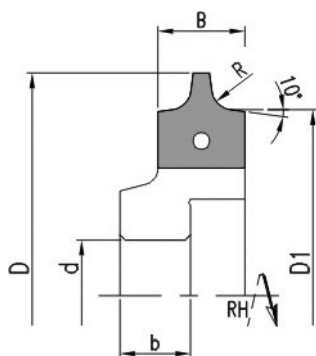

WP-Abrundfräser zum Abrunden der Anleimerkante an Kantenbearbeitungsanlagen
TC-Rounding-cutter with reversible knives. For rounding edge bandings on edge processing units

MEC

HW

| D | B/d | d | DKN | R | Z | n. max | Art. Nr. RH | Art. Nr. LH |
|--------------|-------|----|-------|---|---|--------|---------------------|---------------------|
| Biese | | | | | | | | |
| 70 | 16/19 | 16 | 5x2,3 | 2 | 6 | 18000 | 5174.070.002 | 5174.070.102 |
| 70 | 16/19 | 16 | 5x2,3 | 3 | 6 | 18000 | 5174.070.003 | 5174.070.103 |
| 70 | 16/19 | 16 | 5x2,3 | 4 | 6 | 18000 | 5174.070.004 | 5174.070.104 |
| 70 | 16/19 | 16 | 5x2,3 | 5 | 6 | 18000 | 5174.070.005 | 5174.070.105 |

Wendemesser/Ersatzteile

Reversible knives/Spare parts

| | Dim. | R | Art. Nr. |
|--------------------------------|-----------|-----|----------------|
| Wendemesser - Reversible knife | 16x17,5x2 | R 2 | 765.101 |
| Wendemesser - Reversible knife | 16x17,5x2 | R 3 | 765.102 |
| Wendemesser - Reversible knife | 16x17,5x2 | R 4 | 765.103 |
| Wendemesser - Reversible knife | 16x17,5x2 | R 5 | 765.104 |
| Spannkeil - Clamping wedge | | | 707.155 |
| Gewindestift - Screw | M6x12 | | 705.533 |
| Sechskantschlüssel - T Wrench | SW3 | | 706.103 |

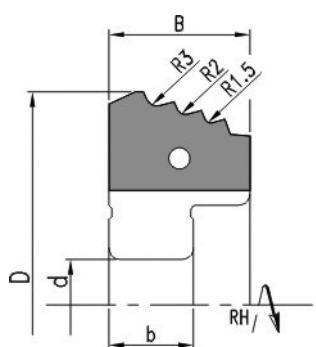

WP-Multi-Abrundfräser für unterschiedliche Radien der Anleimerkante
TC-Multi-rounding-cutter for different radii with reversible knives. For rounding edge bandings

MEC

HW

| D | B | d | DKN | R | Z | n. max | Art. Nr. RH | Art. Nr. LH |
|--------------|----|----|-------|---------|---|--------|---------------------|---------------------|
| Biese | | | | | | | | |
| 75 | 25 | 20 | 6x3,5 | 1,5/2/3 | 4 | 18000 | 5174.075.002 | 5174.075.102 |

Wendemesser/Ersatzteile

Reversible knives/Spare parts

| | Dim. | R | Art. Nr. |
|--------------------------------|-----------|-------------|-------------------|
| Wendemesser - Reversible knife | 25x18,5x2 | R 1,5/R2/R3 | 765.112 |
| Spannkeil - Clamping wedge | | | 707.557.01 |
| Gewindestift - Screw | M6x12 | | 705.533 |
| Sechskantschlüssel - T Wrench | SW3 | | 706.103 |



WP-Abrundfräser mit HSK25R Aufnahme zum Abrunden der Anleimerkante an Kantenbearbeitungsanlagen
 TC-Rounding-cutter with HSK25R adaptor reversible knives. For rounding edge bandings on edge processing units

MEC

HW

| D | b | d | Z | R | n. max | Art. Nr. RH | Art. Nr. LH |
|--------------------|----|--------|---|---|--------|---------------------|---------------------|
| Homag - IMA | | | | | | | |
| 79 | 23 | HSK25R | 4 | 2 | 18000 | 5112.079.002 | 5112.079.102 |
| 79 | 23 | HSK25R | 4 | 3 | 18000 | 5112.079.003 | 5112.079.103 |
| 85 | 24 | HSK25R | 4 | 4 | 17700 | 5112.085.004 | 5112.085.104 |
| 85 | 24 | HSK25R | 4 | 5 | 17700 | 5112.085.005 | 5112.085.105 |

Wechselmesser/Ersatzteile*Reversible knives/Spare parts*

| | R | Dim. | Art. Nr. RH | Art.Nr. LH |
|---|---|----------|-------------------|-------------------|
| Wendemeser - <i>Reversible knife</i> | 2 | 12x17x2 | 765.201 | 765.202 |
| | 3 | 12x17x2 | 765.203 | 765.204 |
| | 4 | 12x20x2 | 765.205 | 765.206 |
| | 5 | 12x20x2 | 765.207 | 765.208 |
| Spannkeil - <i>Clamping wedge</i> | | | 707.900.01 | 707.900.02 |
| Gewindestift - <i>Screw</i> | | M6x12 | | 705.533 |
| Sechskantschlüssel - <i>T Wrench</i> | | SW3 | | 706.103 |
| Spannschraube für - <i>Screw for HSK25R</i> | | M10x1,25 | | 705.099 |
| Sechskantschlüssel - <i>T Wrench</i> | | SW10 | | 706.107 |

Ausführung mit ziehendem Schnitt*With axial angle*

| D | b | d | Z | R | n. max | Art. Nr. RH | Art. Nr. LH |
|--------------------|----|--------|---|---|--------|---------------------|---------------------|
| Homag - IMA | | | | | | | |
| 79 | 23 | HSK25R | 4 | 2 | 18000 | 5112.079.202 | 5112.079.302 |
| 79 | 23 | HSK25R | 4 | 3 | 18000 | 5112.079.203 | 5112.079.303 |

Wechselmesser/Ersatzteile*Reversible knives/Spare parts*

| | R | Dim. | Art. Nr. RH | Art.Nr. LH |
|---|---|----------|-------------------|-------------------|
| Wendemeser - <i>Reversible knife</i> | 2 | 12x17x2 | 765.209 | 765.210 |
| | 3 | 12x17x2 | 765.211 | 765.212 |
| Spannkeil - <i>Clamping wedge</i> | | | 707.902.03 | 707.902.04 |
| Gewindestift - <i>Screw</i> | | M6x12 | | 705.533 |
| Spannschraube für - <i>Screw for HSK25R</i> | | M10x1,25 | | 705.099 |
| Sechskantschlüssel - <i>T Wrench</i> | | SW10 | | 706.107 |

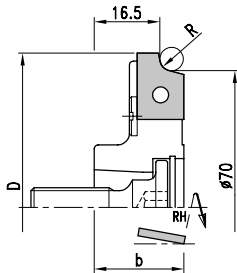
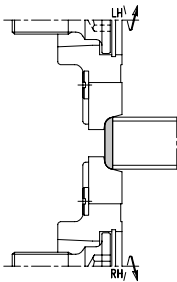
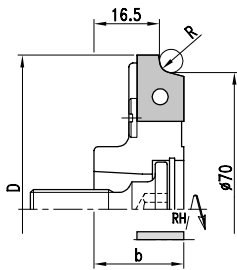

- Mit ziehendem Schnitt
- With axial angle

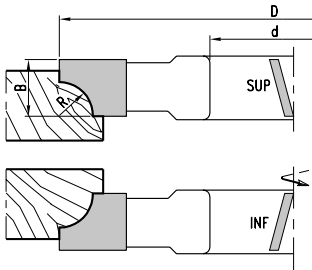

- Mit ziehendem Schnitt
- With axial angle

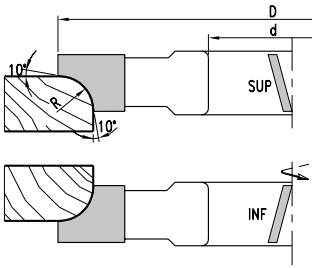

- Mit ziehendem Schnitt
- With axial angle

HW-bestückter Viertelstabfräser zum Abrunden mit ziehendem Schnitt
TC-Tipped quarter round cutter for rounding with axial angle
MAN
HW

| D | B | d | Z | R | n. min-n.max | Art. Nr. RH | Art. Nr. LH |
|-----|----|-------|---|----|--------------|---------------------|---------------------|
| 140 | 12 | 30/50 | 4 | 5 | 5500-9500 | 8619.140.012 | 8619.140.112 |
| | 14 | 30/50 | 4 | 7 | 5500-9500 | 8619.140.014 | 8619.140.114 |
| | 15 | 30/50 | 4 | 8 | 5500-9500 | 8619.140.015 | 8619.140.115 |
| | 17 | 30/50 | 4 | 10 | 5500-9500 | 8619.140.017 | 8619.140.117 |
| | 19 | 30/50 | 4 | 12 | 5500-9500 | 8619.140.019 | 8619.140.119 |
| | 22 | 30/50 | 4 | 15 | 5500-9500 | 8619.140.022 | 8619.140.122 |
| | 27 | 30/50 | 4 | 20 | 5500-9500 | 8619.140.027 | 8619.140.127 |
| 150 | 33 | 30/50 | 4 | 25 | 5200-8900 | 8619.150.033 | 8619.150.133 |
| 160 | 40 | 30/50 | 4 | 30 | 4800-8300 | 8619.160.040 | 8619.160.140 |
| 180 | 50 | 30/50 | 4 | 40 | 4300-7400 | 8619.180.050 | 8619.180.150 |

- Ausführung zum Kehlen für manuellen Vorschub. Ausführung ohne Auslauf.
- *Layout for concave fillets and manual feed. Type without profile relief.*

HW-bestückter Viertelstabfräser zum Abrunden mit ziehendem Schnitt
TC-Tipped quarter round cutter for rounding with axial angle

| D | B | d | Z | R | n. min-n.max | Art. Nr. RH | Art. Nr. LH |
|-----|----|-------|---|----|--------------|---------------------|---------------------|
| 140 | 12 | 30/50 | 4 | 5 | 5500-9500 | 8619.140.212 | 8619.140.312 |
| | 14 | 30/50 | 4 | 7 | 5500-9500 | 8619.140.214 | 8619.140.314 |
| | 15 | 30/50 | 4 | 8 | 5500-9500 | 8619.140.215 | 8619.140.315 |
| | 17 | 30/50 | 4 | 10 | 5500-9500 | 8619.140.217 | 8619.140.317 |
| | 19 | 30/50 | 4 | 12 | 5500-9500 | 8619.140.219 | 8619.140.319 |
| | 22 | 30/50 | 4 | 15 | 5500-9500 | 8619.140.222 | 8619.140.322 |
| | 27 | 30/50 | 4 | 20 | 5500-9500 | 8619.140.227 | 8619.140.327 |
| 150 | 33 | 30/50 | 4 | 25 | 5200-8900 | 8619.150.233 | 8619.150.333 |
| 160 | 40 | 30/50 | 4 | 30 | 4800-8300 | 8619.160.240 | 8619.160.340 |
| 180 | 50 | 30/50 | 4 | 40 | 4300-7400 | 8619.180.250 | 8619.180.350 |

- Ausführung mit beidseitigem Auslauf für manuellen Vorschub
- Ausführung mit 10° Auslauf
- *Layout with relief for manual feed*
- *Type with 10° profile*

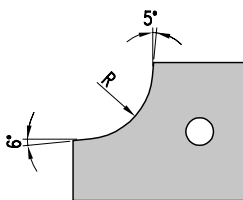
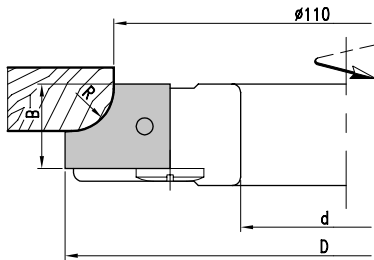
WP-Abrundfräser für verschiedene Radienprofile
TC-Rounding-cutter for reversible knives
MAN
HW

| D | B | d | Z | R | n. min-n.max | Art. Nr. |
|-------|----|-------|---|-------|--------------|-----------------------|
| 125,5 | 20 | 30/50 | 3 | 5/7 | 6100-10500 | ① 4119.126.020 |
| 132,5 | 20 | 30/50 | 3 | 8/10 | 5800-10000 | ① 4119.133.020 |
| 141,0 | 25 | 30/50 | 3 | 12/15 | 5400-9400 | ① 4119.141.025 |

- ① Ohne Wendemesser
- ② *Cutterheads supplied without knives*

- Ausformung des Grundkörpers eignet sich zur Verwendung unterschiedlicher Radienprofile
- Ausführung für manuellen Vorschub
- *The toolbody allows to hold different radius profiles*
- *Layout for manual feed*

Wechselmesser/Ersatzteile
Reversible knives/Spare parts

| | R | Dim. | Art.Nr. |
|---|-------|---------|----------------|
| Wechselmesser - <i>Reversible knife</i> | 5 | 20x20x2 | 775.201 |
| | 7 | 20x20x2 | 775.202 |
| | 8 | 20x25x2 | 775.203 |
| | 10 | 20x25x2 | 775.204 |
| | 12 | 25x30x2 | 775.205 |
| Spannkeil - <i>Clamping wedge</i> | 15 | 25x30x2 | 775.206 |
| | 5/7 | | 707.180 |
| | 8/10 | | 707.181 |
| Gewindestift - <i>Screw</i> | 12/15 | | 707.182 |
| | | M8x16 | 705.542 |
| Sechskantschlüssel - <i>T Wrench</i> | | SW4 | 706.104 |

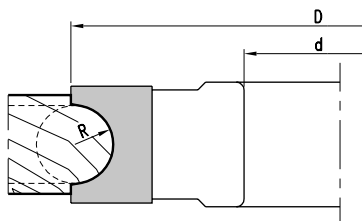
HW-bestückter Halbstabfräser mit achsparallelen Schneiden
TC-Tipped half round cutter with straight cut
MAN
HW

| D | B | d | Z | R | n. min-n.max | Art. Nr. |
|-----|----|-------|---|------|--------------|---------------------|
| 140 | 26 | 30/50 | 4 | 6 | 5500-9500 | 8119.140.026 |
| | 28 | 30/50 | 4 | 7,5 | 5500-9500 | 8119.140.028 |
| | 30 | 30/50 | 4 | 10 | 5500-9500 | 8119.140.030 |
| | 40 | 30/50 | 4 | 12,5 | 5500-9500 | 8119.140.040 |
| | 45 | 30/50 | 4 | 15 | 5500-9500 | 8119.140.045 |
| | 50 | 30/50 | 4 | 17,5 | 5500-9500 | 8119.140.050 |
| | 55 | 30/50 | 4 | 20 | 5500-9500 | 8119.140.055 |
| 150 | 65 | 30/50 | 4 | 25 | 5200-8900 | 8119.150.065 |

- Serienartikel, kurzfristige Fertigung bei Bestellung
- *Standard article, short-time production after order*

4179

HW Halbstabfräser - Wechselmesser

TC Half round cutter - Reversible knife

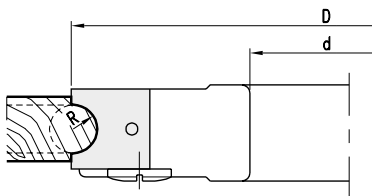
PG
02

HW-bestückter Halbstabfräser mit achsparallelen Schneiden

TC-Tipped half round cutter with straight cut

MAN

HW

| D | B | d | Z | R | n. min-n.max | Art. Nr. |
|-----|----|-------|---|-------|--------------|----------------|
| 140 | 20 | 30/50 | 3 | 4/5/6 | 5500-9500 | ① 4179.140.020 |
| | 30 | 30/50 | 3 | 8/10 | 5500-9500 | ① 4179.140.030 |

- ① Ohne Wendemesser
- ① Cutterheads supplied without knives

- Ausführung für manuellen Vorschub
- Bitte bestellen Sie mit Angabe des gewünschten Radius
- Layout for manual feed
- Please order with needed radius

Wechselmesser/Ersatzteile

Reversible knives/Spare parts

| | R | Dim. | Art.Nr. |
|--------------------------------|-------|---------|------------|
| Wendemesser - Reversible knife | 4 | 20x20x2 | 785.761 |
| | 5 | 20x20x2 | 785.762 |
| | 6 | 20x20x2 | 785.763 |
| | 8 | 30x25x2 | 785.764 |
| | 10 | 30x25x2 | 785.765 |
| Spannkeil - Clamping wedge | 4/5/6 | | 707.002.18 |
| | 8/10 | | 707.812 |
| Gewindestift - Screw | | M8x16 | 705.542 |
| Sechskantschlüssel - T.Wrench | | SW4 | 706.104 |

8184

HW Hochkehlfräser - Festbestückt

TC Half round convex cutter - Tipped

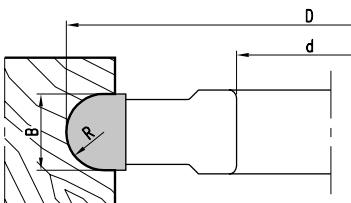
PG
02

HW-bestückter Hohlkehlfräser mit achsparallelen Schneiden

TC-Tipped half round convex cutter with straight cut

MAN

HW

| D | B | d | Z | R | n. min-n.max | Art. Nr. |
|-----|----|-------|---|------|--------------|--------------|
| 140 | 5 | 30/50 | 4 | 2,5 | 5500-9500 | 8184.140.005 |
| | 6 | 30/50 | 4 | 3,0 | 5500-9500 | 8184.140.006 |
| | 8 | 30/50 | 4 | 4,0 | 5500-9500 | 8184.140.008 |
| | 10 | 30/50 | 4 | 5,0 | 5500-9500 | 8184.140.010 |
| | 12 | 30/50 | 4 | 6,0 | 5500-9500 | 8184.140.012 |
| | 15 | 30/50 | 4 | 7,5 | 5500-9500 | 8184.140.015 |
| | 20 | 30/50 | 4 | 10,0 | 5500-9500 | 8184.140.020 |
| | 40 | 30/50 | 4 | 20,0 | 5500-9500 | 8184.140.040 |

- Ausführung für manuellen Vorschub
- Layout for manual feed

8679

HW Halbhohlkehlfräser - Festbestückt

TC Quarter round convex cutter - Tipped

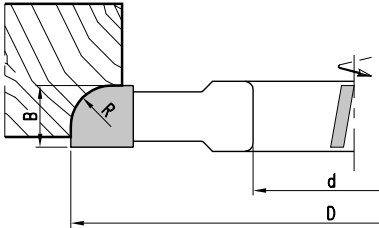
PG
02

HW-bestückter Halbhohlkehlfräse, Schneiden mit Achswinkel
TC-Tipped quarter round convex cutter with axial angle

MAN

HW

| D | B | d | Z | R | n. min-n.max | Art. Nr. |
|-----|----|-------|---|----|--------------|---------------------|
| 140 | 10 | 30/50 | 4 | 5 | 5500-9500 | 8679.140.010 |
| | 15 | 30/50 | 4 | 10 | 5500-9500 | 8679.140.015 |
| | 20 | 30/50 | 4 | 15 | 5500-9500 | 8679.140.020 |
| | 25 | 30/50 | 4 | 20 | 5500-9500 | 8679.140.025 |

- Ausführung für manuellen Vorschub
- Mit ziehendem Schnitt
- *Layout for manual feed*
- *With axial angle*

8719

HW Harzgallenfräser - Festbestückt

TC Resin pocket cutter - Tipped

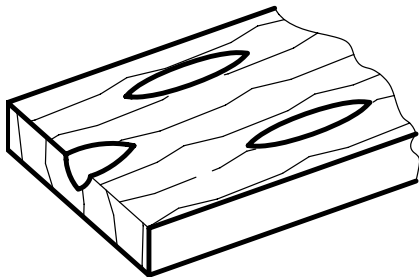
PG
02

Zum Ausfräsen von verharzten oder beschädigten Stellen mit Handmaschine
TC-Tipped resin pocket cutter fits f.ex. to repair system Lamello MINISPOT 8mm

MAN

HW

| D | B | d | Z | ML | n. min-n.max | Art. Nr. |
|-----|----|----|---|----------|--------------|---------------------|
| 100 | 8 | 22 | 4 | 4/4,3/36 | 7800-13300 | 8719.100.008 |
| | 15 | 22 | 4 | 2/4,3/36 | 7800-13300 | 8719.100.015 |

- Ausführung für manuellen Vorschub
- *Layout for manual feed*

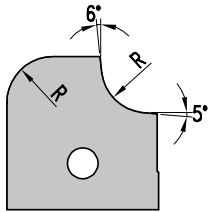
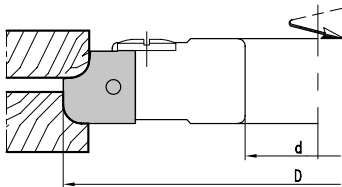
WP-Radius-Profilfräser für verschiedene Radienprofile
TC-Radius-Profilecutter for reversible knives and different radiusprofiles
MAN
HW

| D | B | d | Z | R | n. min-n.max | Art. Nr. |
|-----|----|-------|---|-------|--------------|-----------------------|
| 140 | 20 | 30/50 | 3 | 5/6/7 | 5500-9500 | ① 4189.140.020 |
| | 25 | 30/50 | 3 | 8/10 | 5500-9500 | ① 4189.140.025 |

① Ohne Wechselmesser

 ① *Cutterheads supplied without knives*

- Einseitig als Abplattfräser (gerade Abplattung) einsetzbar
- Ausführung für manuellen Vorschub
- *Tool can be used on one side as panel raising cutter (straight panel raising)*
- *Layout for manual feed*

Wechselmesser/Ersatzteile
Reversible knives/Spare parts

| | R | Dim. | Art.Nr. |
|---|-------|-----------|-------------------|
| Wechselmesser - <i>Reversible knife</i> | 5 | 20x20x2 | 785.766 |
| | 6 | 20x20x2 | 785.767 |
| | 7 | 20x20x2 | 785.772 |
| | 8 | 30x25x2 | 785.773 |
| | 10 | 30x25x2 | 785.770 |
| Spannkeil - <i>Clamping wedge</i> | 5/6/7 | | 707.002.18 |
| | 8/10 | | 707.811 |
| Gewindestift - <i>Screw</i> | 5/6/7 | M8x16 | 705.542 |
| | 8/10 | M10x20 | 705.552 |
| Sechskantschlüssel - <i>T Wrench</i> | | SW4 (M8) | 706.104 |
| | | SW5 (M10) | 706.105 |



HW-bestückte Multi-Dübelfräser zum Fräsen glatter oder geriffelter Rundstäbe
TC-Tipped multiple dowel cutter for smooth or serrated dowels

MAN

HW

| D | d | n.max | Art. Nr. RH | Art.Nr. LH |
|---------|---------|-------|---------------------|---------------------|
| 120-130 | 30(-50) | 10200 | 8114.120.102 | 8114.120.202 |
| 131-140 | 30(-50) | 9500 | 8114.131.095 | 8114.131.195 |
| 141-150 | 30(-50) | 8900 | 8114.141.089 | 8114.141.189 |
| 151-160 | 30(-50) | 8300 | 8114.151.083 | 8114.151.183 |

- Gemäß DIN 68150
- According to DIN 68150

- Ausführung mit achparallelen Schneiden mechanischen Vorschub
- Serienartikel, kurzfristige Fertigung bei Bestellung
- *Layout with straight cut for mechanical feed*
- *Standard article, short-time production after order*

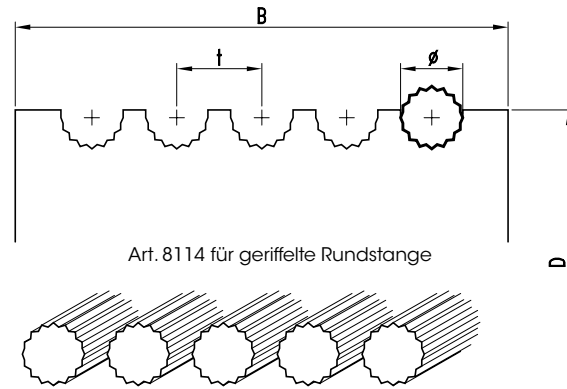
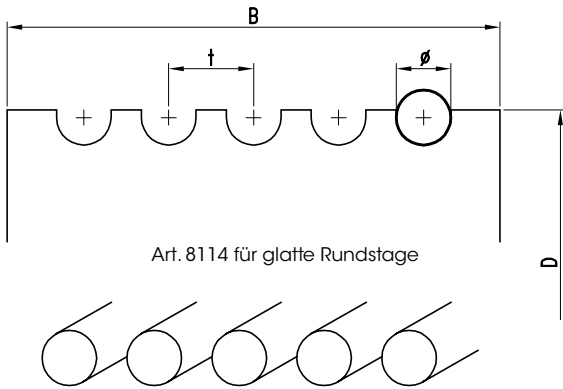

HS

| | 6 | 8 | 10 | 12 | 14 | 15 | 16 | 18 | 20 | 25 |
|------------------------------------|----|----|----|------|-------|-------|-------|-------|-------|-----|
| t | 7 | 9 | 11 | 13,5 | 15,5 | 16,5 | 17,5 | 19,5 | 22 | 27 |
| B= Schnittbreite - B= Cutter width | | | | | | | | | | |
| 2 | 23 | 27 | 31 | 35,5 | 39,5 | 41,5 | 43,5 | 47,5 | 56 | 66 |
| 3 | 30 | 36 | 42 | 49 | 55 | 58 | 61 | 67 | 78 | 93 |
| • Stabanzahl • Nr. of dowels | 4 | 37 | 45 | 53 | 62,5 | 70,5 | 74,5 | 78,5 | 86,5 | 100 |
| | 5 | 44 | 54 | 64 | 76 | 86 | 91 | 96 | 106 | 122 |
| | 6 | 51 | 63 | 75 | 89,5 | 101,5 | 107,5 | 113,5 | 125,5 | - |
| | 7 | 58 | 72 | 86 | 103 | 117 | 124 | - | - | - |
| | 8 | 65 | 81 | 97 | 116,5 | - | - | - | - | - |

Berechnung für Randstegbreite 5mm
Calculated for nose-piece 5mm

- Für optimale Ergebnisse sind Niederhalter erforderlich
- *In order to ensure perfect machining of dowels, the application of a guide rail is recommended*

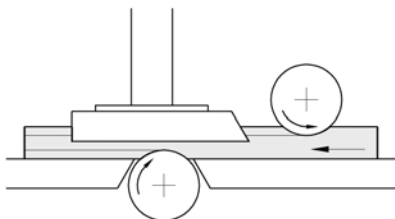

8169

HW Multi-Profilfräser - Festbestückt
 TC Multi-Profilecutter - Tipped

PG
02



HW-bestückte Multiprofilfräser mit achparallelen Schneiden
 TC-Tipped Multi-profilecutter with straight cut

MAN

HW

| Nr | D | B | d | Z | n. min-n.max | Art.Nr. |
|----|-----|----|----|---|--------------|---------------------|
| 1 | 120 | 40 | 30 | 2 | 6400-11100 | 8169.120.040 |
| 1 | 140 | 40 | 50 | 3 | 5500-9500 | 8169.140.040 |
| 2 | | 50 | 50 | 3 | 5500-9500 | 8169.140.050 |

- Ausführung für manuellen Vorschub
- *Layout for manual feed*

- Profilbeispiel
- *profile example*

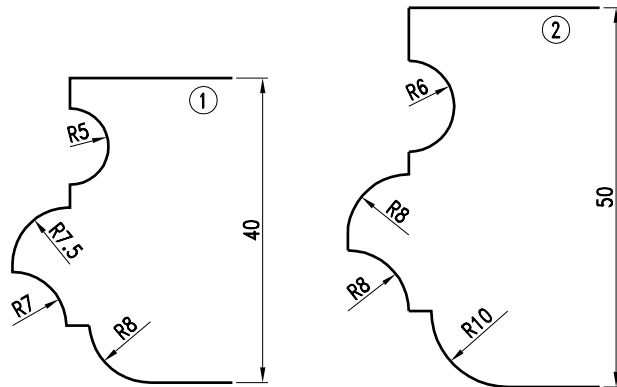

9199

HW Multi-Profilfräser - Wechselsmesser
 TC Multi-Profilecutter - Reversible knife

PG
02



WP-bestückte Multiprofilfräser mit achparallelen Schneiden
 TC-Multi-Profilecutter for reversible knives with straight cut

MAN

HW

| D | B | d | Z | n. min-n.max | Art.Nr. |
|-----|----|-------|---|--------------|-----------------------|
| 140 | 50 | 30/50 | 2 | 5500-9500 | ① 9199.140.050 |

- ① Ausführung mit Leichtmetall-Grundkörper
- ① *With light alloy body*
- HW-Sonderprofilmesser können ca. 3-4 Monate nachgeschärft werden
- Ausführung für manuellen Vorschub
- *TC-Special profile knives are resharpenable 3 to 4 times*
- *Layout for manual feed*

Wechselsmesser/Ersatzteile
 Reversible knives/Spare parts

| | Dim. | Art.Nr. |
|--|---------|----------------|
| Wechselsmesser - <i>Reversible knife</i> | 50x30x2 | 785.771 |
| Spannkeil - <i>Clamping wedge</i> | | 707.952 |
| Gewindestift - <i>Screw</i> | M8x16 | 705.542 |
| Sechskantschlüssel - <i>T Wrench</i> | SW4 | 706.104 |

- Blanketts nach Kundenwunsch frei profilierbar
- *Individual design of profile blanks*

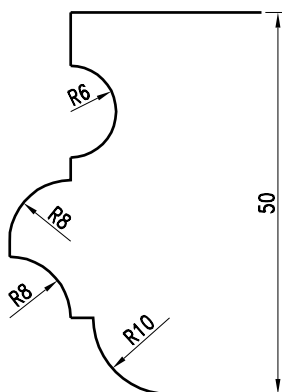

- Profilbeispiel
- *profile example*



4199

HW Multi-Profilfräser Typ F - Wechselmesser
TC Multi-Profilecutter Type F - Reversible knife

PG
02

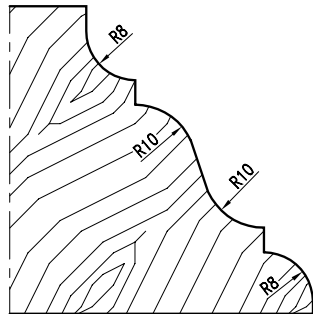
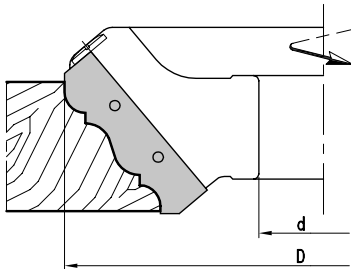

WP-bestückte Multiprofilfräser mit achparallelen Schneiden
TC-Multi-Profilecutter for reversible knives with straight cut

MAN

HW

| D | B | d | Z | n.min-n.max | Art.Nr. LH |
|-----|----|-------|---|-------------|---------------------|
| 200 | 70 | 30/50 | 2 | 4500-7800 | 4199.200.070 |

- Serienartikel, kurzfristige Fertigung bei Bestellung
- HW-Sonderprofilmesser können ca. 3-4 Monate nachgeschärft werden
- Ausführung für manuellen Vorschub
- *Standard article, short-time production after order*
- *TC-Special profile knives are resharpenable 3 to 4 times*
- *Layout for manual feed*

Wechselmesser/Ersatzteile
Reversible knives/Spare parts

| | Dim. | Art.Nr. |
|---|---------|-------------------|
| Wechselmesser - <i>Reversible knife</i> | 70x20x2 | 785.783 |
| Spannkeil - <i>Clamping wedge</i> | | 707.002.68 |
| Gewindestift - <i>Screw</i> | M8x16 | 705.542 |
| Sechskantschlüssel - <i>T Wrench</i> | SW4 | 706.104 |

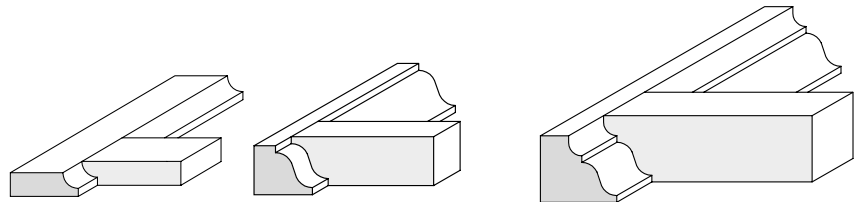

8689

HW Handlaufräser - Festbestückt
TC Handrail profilecutter - Tipped

PG
02



Fräswerkzeuge mit Bohrung, profiliert
Tools with bore, profiled

MAN

HW

| Nr. | D | B | d | Z | n.min-n.max | Art.Nr. LH |
|-----|-----|----|-------|---|-------------|---------------------|
| 1 | 150 | 40 | 30/50 | 3 | 5200-8900 | 8689.150.040 |
| 2 | | 70 | 30/50 | 3 | 5200-8900 | 8689.150.070 |
| 3 | | 55 | 30/50 | 3 | 5200-8900 | 8689.150.055 |
| 4 | 160 | 75 | 30/50 | 3 | 4800-8300 | 8689.160.075 |
| 5 | 180 | 55 | 30/50 | 3 | 4300-7400 | 8689.180.055 |

- Serienartikel, kurzfristige Fertigung bei Bestellung
- *Standard article, short-time production after order*

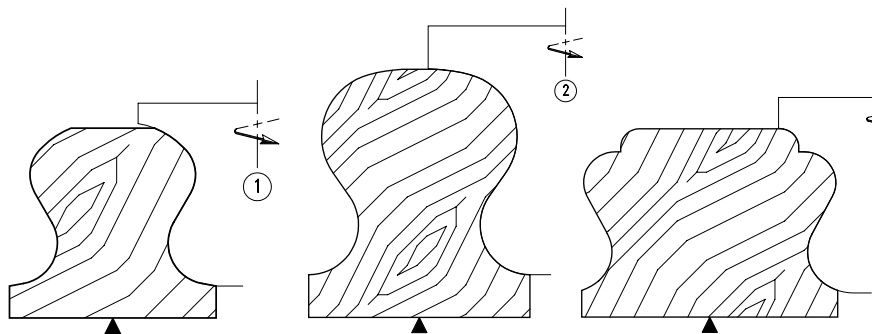

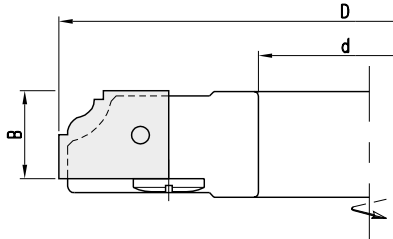

•Typ A: Standard Blankett

•Type A: Standard blank

Mit achparallelen Schneiden zur Aufnahme von HW-Sonderprofilmessern mit Stützplatte.
 TC-Multi-Profilecutter with straight cut. Cutterhead for TC-special profile knives and backing plates.

MEC

HW

| D | B | d | Z | n.min-n.max | Art.Nr. LH |
|-----|----|----|---|-------------|--------------|
| 140 | 20 | 50 | 3 | 9500 | 9114.140.020 |

- ohne Wechselmesser
- Zur Aufnahme von HW-Sonderprofilmessern
- HW-Sonderprofilmesser können ca. 3-4 Monate nachgeschärft werden
- Ausführung für mechanischen Vorschub
- *Cutterheads supplied without reversible knives*
- *Standard article, short-time production after order*
- *TC-Special profile knives are resharpenable 3 to 4 times*
- *Layout for mechanical feed*

Wechselmesser/Ersatzteile
 Reversible knives/Spare parts

| | P | Dim. | Art.Nr. |
|----------------------------------|----|---------|---------|
| Wechselmesser - Reversible knife | 1 | 20x25x2 | 785.631 |
| | 2 | 20x25x2 | 785.632 |
| | 3 | 20x25x2 | 785.633 |
| | 4 | 20x25x2 | 785.634 |
| | 5 | 20x25x2 | 785.635 |
| | 6 | 20x25x2 | 785.636 |
| | 7 | 20x25x2 | 785.637 |
| | 8 | 20x25x2 | 785.638 |
| | 9 | 20x25x2 | 785.639 |
| | 10 | 20x25x2 | 785.640 |
| | 11 | 20x25x2 | 785.641 |
| | 12 | 20x25x2 | 785.642 |
| | 13 | 20x25x2 | 785.643 |
| | 14 | 20x25x2 | 785.644 |
| | 15 | 20x25x2 | 785.645 |
| | 16 | 20x25x2 | 785.646 |
| Spannkeil - Clamping wedge | | | 707.090 |
| Gewindestift - Screw | | M8x16 | 705.542 |
| Sechskantschlüssel - T Wrench | | SW4 | 706.104 |

- Blanketts nach Kundenwunsch frei profilierbar
- *Individual design of profile blanks*

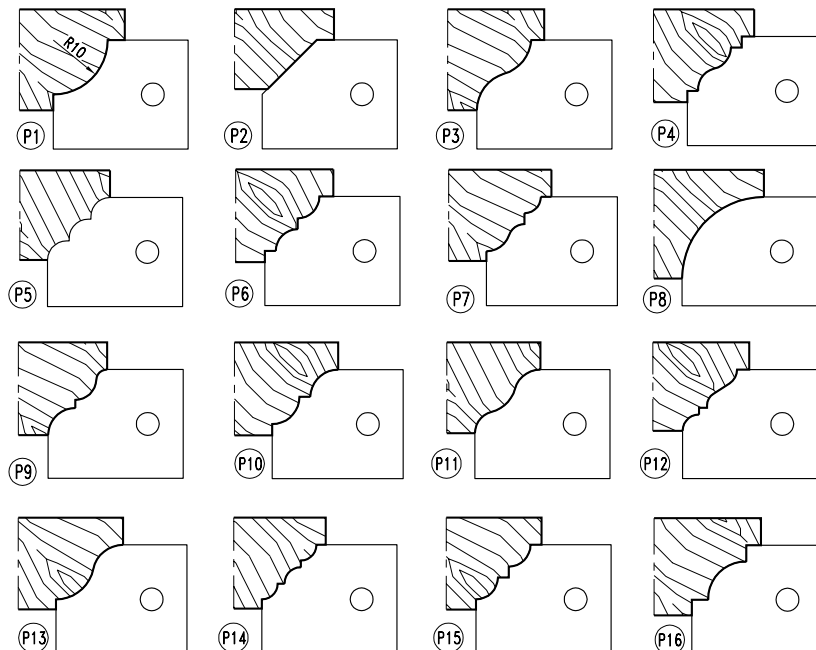

Mit achparallelen Schneiden zur Aufnahme von HW-Sonderprofilmessern mit Stützplatte
 TC-Multi-Profilecutter with straight cut. Cutterhead for TC-special profile knives and backing plates.

MEC

HW

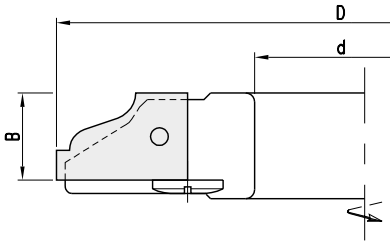

•Typ B: Standardblankett
 •Type B: standard blank

| D | B | d | Z | n.min-n.max | Art.Nr. LH |
|-----|----|----|---|-------------|--------------|
| 140 | 20 | 50 | 3 | 9500 | 4134.140.020 |

- Ohne Wechseltmesser
- HW-Sonderprofilmesser können ca. 3-4 Monate nachgeschärft werden
- Ausführung für mechanischen Vorschub
- *Cutterheads without reversible knives*
- *TC-Special profile knives are resharpenable 3 to 4 times*
- *Layout for mechanical feed*

Wechseltmesser/Ersatzteile
Reversible knives/Spare parts

| | P | Dim. | Art.Nr. |
|--|----|---------|---------|
| Wechseltmesser - <i>Reversible knife</i> | 1 | 20x30x2 | 785.651 |
| | 2 | 20x30x2 | 785.652 |
| | 3 | 20x30x2 | 785.653 |
| | 4 | 20x30x2 | 785.654 |
| | 5 | 20x30x2 | 785.655 |
| | 6 | 20x30x2 | 785.656 |
| | 7 | 20x30x2 | 785.657 |
| | 8 | 20x30x2 | 785.658 |
| | 9 | 20x30x2 | 785.659 |
| | 10 | 20x30x2 | 785.660 |
| | 11 | 20x30x2 | 785.661 |
| | 12 | 20x30x2 | 785.662 |
| | 13 | 20x30x2 | 785.663 |
| | 14 | 20x30x2 | 785.664 |
| | 15 | 20x30x2 | 785.665 |
| | 16 | 20x30x2 | 785.666 |
| | 17 | 20x30x2 | 785.667 |
| | 18 | 20x30x2 | 785.668 |
| Spannkeil - <i>Clamping wedge</i> | | | 707.086 |
| Gewindestift - <i>Screw</i> | | M8x16 | 705.542 |
| Sechskantschlüssel - <i>T Wrench</i> | | SW4 | 706.104 |

- Blanketts nach Kundenwunsch frei profilierbar
- *Individual design of profile blanks*

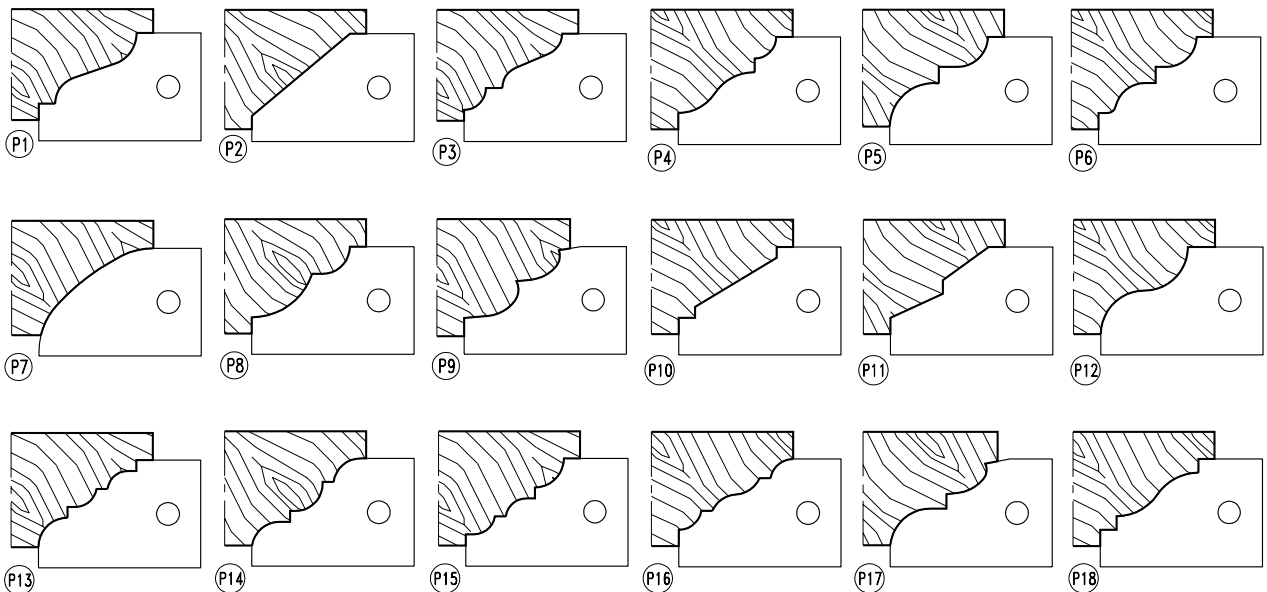

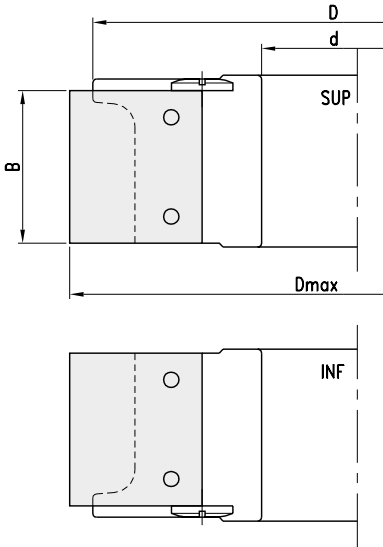

- Typ E: Standardblankett
- Type E: Standard blank

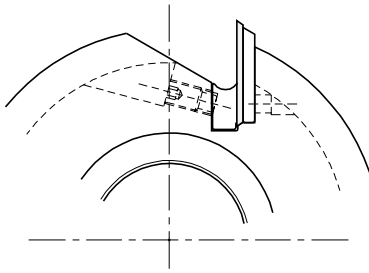

- Klemmung: Standardblankett
- Clamping: Standard blank

Mit achparallelen Schneiden zur Aufnahme von HW-Sonderprofilmessern mit Stützplatte
 TC-Multi-Profilecutter with straight cut. Cutterhead for TC-special profile knives and backing plates.

MEC

HW

| D | B | d | Z | n.min-n.max | Art.Nr. |
|-----|----|-------|---|-------------|---------------------|
| 138 | 40 | 30/50 | 3 | 9000 | 9184.138.040 |
| | 50 | 30/50 | 3 | 9000 | 9184.138.050 |
| | 60 | 30/50 | 3 | 9000 | 9184.138.060 |

- Ohne Messer und Stützplatten
- HW-Sonderprofilmesser können ca. 3-4 Monate nachgeschärft werden
- Ausführung für mechanischen Vorschub
- *Knives and back support not included*
- *TC-Special profile knives are resharpenable 3 to 4 times*
- *Layout for mechanical feed*

Ersatzteile
Spare parts

| | Dim. | Art.Nr. |
|-------------------------------|-------|-------------------|
| Spannkeil - Clamping wedge | 40 | 707.300.38 |
| | 50 | 707.300.48 |
| | 60 | 707.300.58 |
| Gewindestift - Screw | M8x16 | 705.542 |
| Sechskantschlüssel - T Wrench | SW4 | 706.104 |

Wechselmesser/Ersatzteile
Reversible knives/Spare parts

| | Dmax | Dim. | B | Art.Nr. |
|----------------------------------|------|-----------|----|----------------|
| Wechselmesser - Reversible knife | 140 | 40x30x2 | 40 | 769.203 |
| | | 50x30x2 | 50 | 769.205 |
| | | 60x30x2 | 60 | 769.215 |
| Stützplatten - Back support | 140 | 40x35x2 | 40 | 769.204 |
| | | 50x35x2 | 50 | 769.206 |
| | | 60x35x2 | 60 | 769.208 |
| Stützplatten - Back support | 150 | 38x26x3,8 | 40 | 710.201 |
| | | 48x26x3,8 | 50 | 710.202 |
| | | 58x26x3,8 | 60 | 710.203 |
| Stützplatten - Back support | 150 | 38x31x3,8 | 40 | 710.210 |
| | | 48x31x3,8 | 50 | 710.211 |
| | | 58x31x3,8 | 60 | 710.212 |

- Blanketts nach Kundenwunsch frei profilierbar
- *Individual design of profile blanks*



 Profilerzone (1:1)
 Available area for profiling (1:1)

- Alle Blanketts auch im System 2-Punkt Auflage erhältlich
- On request we supply all reversible knives with 2-point seating

Typ E • Type E

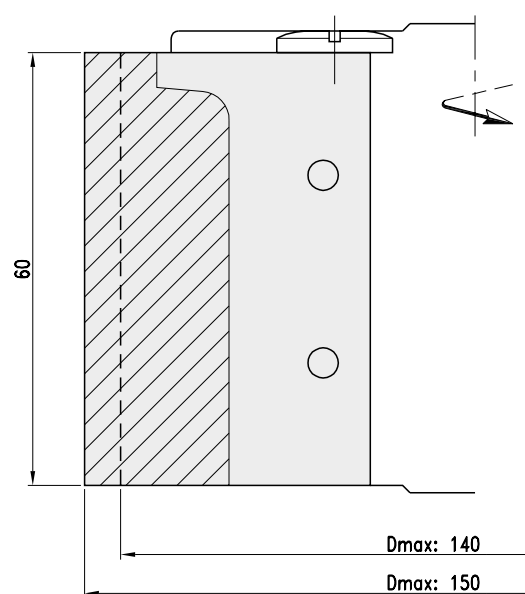
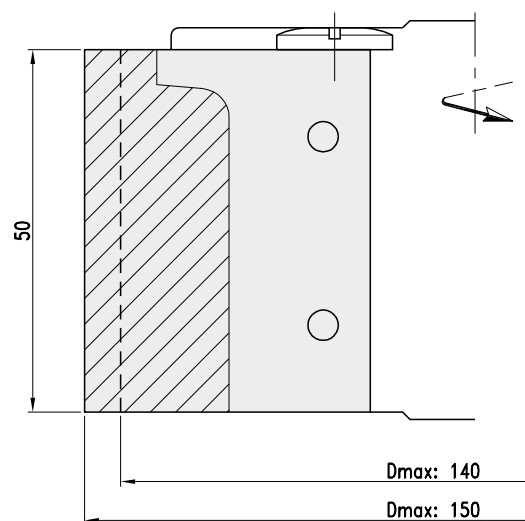
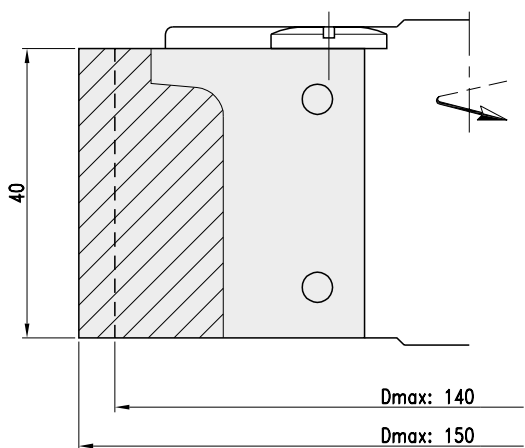

- Standardblankett
- Standard blank

Typ C • Type C

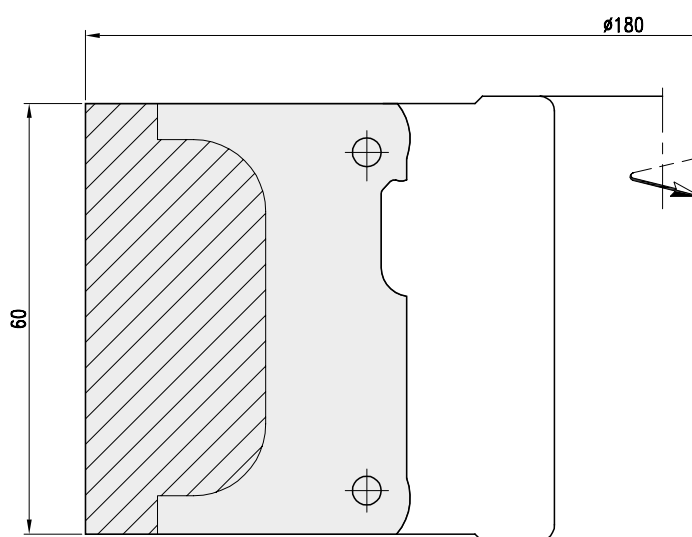
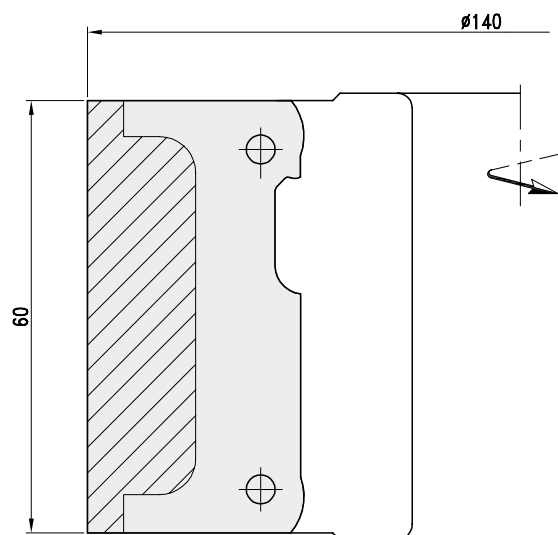
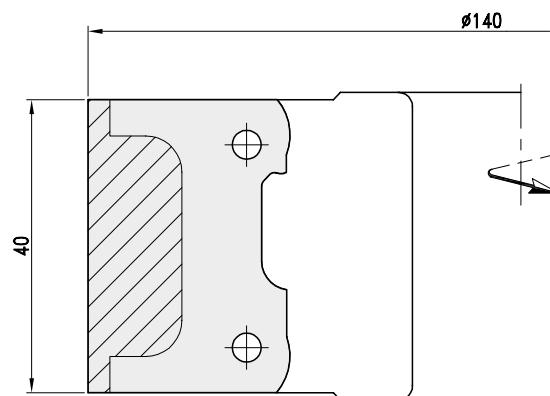

- Blankett mit 2-Punkt Auflage
- Blank with 2-point seating



Monoblock-Profilmesserkopf für universelles Profilieren auf Kehlmaschinen HSK85WS Schnittstelle
Monobloc-Profilecutterhead for profiling on moulders with HSK85WS interface.

MEC**HW**

| D | B | S | Z | n max. | Art. Nr. LH | Art. Nr. RH |
|----|-----|---------|---|--------|----------------|--------------|
| 90 | 60 | HSK85WS | 2 | 1200 | ● 2412.090.060 | 2412.090.160 |
| | 80 | HSK85WS | 2 | 1200 | ● 2412.090.080 | 2412.090.180 |
| | 100 | HSK85WS | 2 | 1200 | ● 2412.090.100 | 2421.090.200 |
| | 130 | HSK85WS | 2 | 1200 | ● 2412.090.130 | 2412.090.230 |
| | 150 | HSK85WS | 2 | 1200 | ● 2412.090.150 | 2412.090.250 |
| | 170 | HSK85WS | 2 | 1200 | ● 2412.090.170 | 2412.090.270 |
| | 190 | HSK85WS | 2 | 1200 | ● 2412.090.190 | 2412.090.290 |
| | 210 | HSK85WS | 2 | 1200 | ● 2412.090.210 | 2412.090.310 |
| | 240 | HSK85WS | 2 | 1200 | ● 2412.090.240 | 2412.090.340 |
| 90 | 60 | HSK85WS | 4 | 1200 | ● 2412.090.062 | 2412.090.162 |
| | 80 | HSK85WS | 4 | 1200 | ● 2412.090.082 | 2412.090.182 |
| | 100 | HSK85WS | 4 | 1200 | ● 2412.090.102 | 2412.090.202 |
| | 130 | HSK85WS | 4 | 1200 | ● 2412.090.132 | 2412.090.232 |
| | 150 | HSK85WS | 4 | 1200 | ● 2412.090.152 | 2412.090.252 |
| | 170 | HSK85WS | 4 | 1200 | ● 2412.090.172 | 2412.090.272 |
| | 190 | HSK85WS | 4 | 1200 | ● 2412.090.192 | 2412.090.292 |
| | 210 | HSK85WS | 4 | 1200 | ● 2412.090.212 | 2412.090.312 |
| | 240 | HSK85WS | 4 | 1200 | ● 2412.090.242 | 2412.090.342 |

- Ohne rückenverzahnte Hobelmesser
Cutterhead supplied without knives
- Bei Verwendung der Standard-Spannkeile passen RVZ-Messer der Stärken 8mm - 10mm.
- Zum Spannen von schwächeren RVZ-Messern als 8mm sind Sonder-Spannkeile zu verwenden.
- Bearbeitung abrasiver Werkstoffe durch die Verwendung des verschleißfesten HW-Massiv-Messersystems mit Mikroverzahnung. Siehe Kapitel Ersatzteile.
- *The use of standard-clamping wedges of serrated knives with thickness of 8mm - 10mm. To clamp serrated knives with smaller thickness than 8mm, special clamping wedges have to be used. Machining of abrasive materials by using TC-solid knife system with micro serrations. See chapter spare parts.*
- Art. 2412: Maximale Profiltiefen in Abhängigkeit der Messerhöhe H

| H | Pi max | |
|----|--------|--------|
| | HS | HW |
| 50 | 20 | 20 |
| 60 | 28 | 20/25* |
| 70 | 38 | 24/35* |

*System Mikroverzahnung
 *Microserrated system

Ersatzteile
Spare parts

| | Dim. | Art.Nr. |
|-------------------------------|--------|---------|
| Gewindestift - Screw | M8x16 | 705.556 |
| | M10x20 | 705.552 |
| Sechskantschlüssel - T Wrench | SW4 | 706.106 |

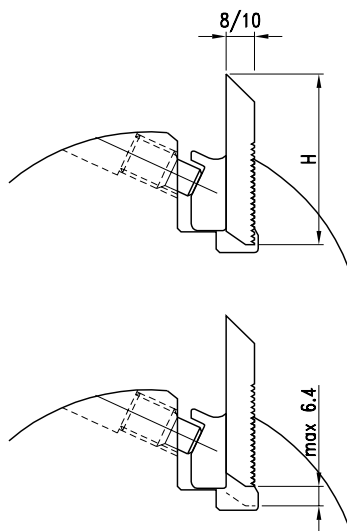

- Ohne rückenverzahnte Hobelmesser
- Cutterhead supplied without knives

Profilmesserkopf für rückenverzahnte Messer und Abweiser.
Profile cutterhead for serrated back blank knives and limitors.
MEC**HW**

| D | B | d | Z | n min - n max | Art.Nr. |
|-----|-----|-------|-----|---------------|---------------------|
| 122 | 40 | 30/40 | 2+2 | 4300-7400 | 2119.122.040 |
| | 60 | 30/40 | 2+2 | 4300-7400 | 2119.122.060 |
| | 80 | 30/40 | 2+2 | 4300-7400 | 2119.122.080 |
| | 100 | 30/40 | 2+2 | 4300-7400 | 2119.122.100 |
| 137 | 40 | 50 | 2+2 | 4000-6800 | 2119.137.040 |
| | 60 | 50 | 2+2 | 4000-6800 | 2119.137.060 |
| | 80 | 50 | 2+2 | 4000-6800 | 2119.137.080 |
| | 100 | 50 | 2+2 | 4000-6800 | 2119.137.100 |

- Ohne RVZ Messer
Cutterhead without knives
- Hochgenaue Messerspannung durch 60° verzahnte Messer. Große Auswahl verschiedener Schneidstoffe für optimale Anpassung an den Werkstückstoff.
- Ausführung für manuellen Vorschub.
High-precision clamped 60° serrated back knives. Wide selection of different cutting materials for optimum choice with regard to the workpiece material. Layout for manual feed.

Ersatzteile
Spare parts

| | Dim. | Art.Nr. |
|--------------------------------------|--------|--------------------|
| Spannkeil - <i>Clamping wedge</i> | 40 | 707.853.40 |
| | 60 | 707.853.60 |
| | 80 | 707.853.80 |
| | 100 | 707.853.100 |
| Gewindestift - <i>Screw</i> | M12x20 | 705.556 |
| | M10x20 | 705.552 |
| Sechskantschlüssel - <i>T Wrench</i> | SW6 | 706.106 |

- Bei Verwendung der Standard-Spannkeile passen RVZ-Messer der Stärken 8mm - 10mm.
- Zum spannen von schwächeren RVZ-Messern als 8mm sind Sonder-Spannkeile zu verwenden.
- Bearbeitung abrasiver Werkstoffe durch die Verwendung des verschleißfesten HW-Maßiv-Messersystems mit Mikroverzahnung. Siehe Kapitel Ersatzteile.
- *The use of standard-clamping wedges for clamping of serrated knives with thickness of 8mm - 10mm.*
- *To clamp serrated knives with smaller thickness than 8mm, special clamping wedges have to be used.*
- *Machining of abrasive materials by using TC-solid knife system with micro serrations. See chapter spare parts.*

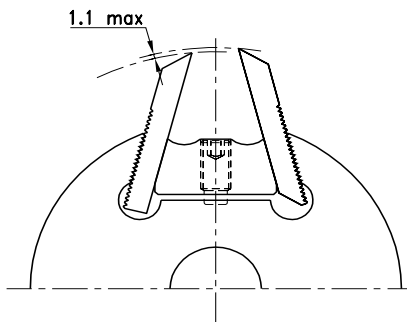
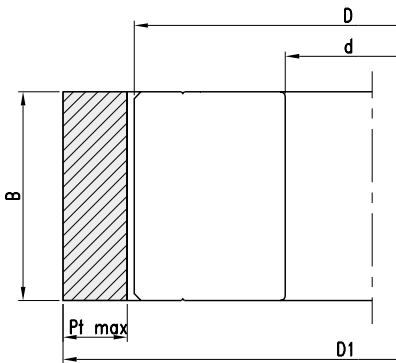

Art. 2119:
 Flugkreisdurchmesser, max. Profiltiefe in Abhängigkeit
 von Fräserdurchmesser D und Messerhöhe H

| H | D1 | | Pt max | |
|----|-------|-------|--------|--------|
| | D 122 | D 137 | HS | HW |
| 50 | 155 | 170 | 12 | 11/12* |
| 60 | 175 | 190 | 20 | 17/20* |

* System Mikroverzahnung

* *Microserrated system*

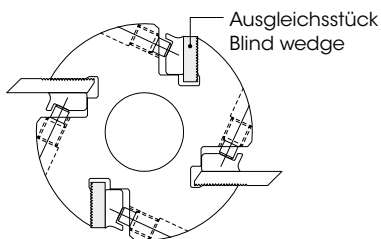
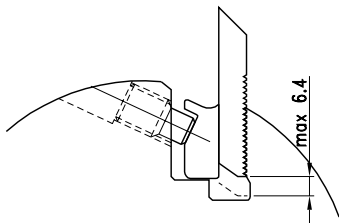
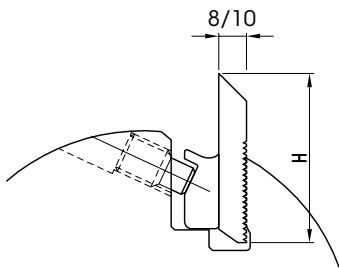
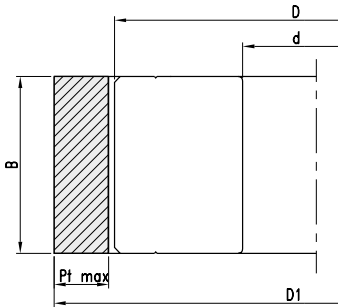

Art. 2114:
 Flugkreisdurchmesser, max. Profiltiefe in
 Abhängigkeit von Fräserdurchmesser D
 und Messerhöhe H

Profilmesserkopf für rückenverzahnte Messer und Abweiser.
Profile cutterhead for serrated back blank knives and limitors.

MEC**HW**

| D | B | d | Z | n max | Art.Nr. |
|-----|-----|----|---|-------|---------------------|
| 122 | 40 | 40 | 2 | 9000 | 2114.122.040 |
| | 60 | 40 | 2 | 9000 | 2114.122.060 |
| | 80 | 40 | 2 | 9000 | 2114.122.080 |
| 122 | 40 | 40 | 4 | 9000 | 2114.122.140 |
| | 60 | 40 | 4 | 9000 | 2114.122.160 |
| | 80 | 40 | 4 | 9000 | 2114.122.180 |
| | 100 | 40 | 4 | 9000 | 2114.122.100 |
| | 130 | 40 | 4 | 9000 | 2114.122.130 |
| | 150 | 40 | 4 | 9000 | 2114.122.150 |
| 137 | 40 | 50 | 4 | 9000 | 2114.122.280 |
| | 60 | 50 | 4 | 9000 | 2114.122.230 |
| | 80 | 50 | 4 | 9000 | 2114.137.040 |
| | 100 | 50 | 4 | 9000 | 2114.137.060 |
| | 130 | 50 | 4 | 9000 | 2114.137.080 |
| | 150 | 50 | 4 | 9000 | 2114.137.100 |
| | 180 | 50 | 4 | 9000 | 2114.137.130 |
| | 150 | 50 | 4 | 9000 | 2114.137.150 |
| | 180 | 50 | 4 | 9000 | 2114.137.180 |

- Ohne RVZ Messer
Cutterhead without knives
- Hochgenaue Messerspannung durch 60° verzahnte Messer. Große Auswahl verschiedener Schneidstoffe für optimale Anpassung an den Werkstückstoff. Ausführung für manuellen Vorschub.
- High-precision clamped 60° serrated back knives. Wide selection of different cutting materials for optimum choice with regard to the workpiece material. Layout for manual feed.

Ersatzteile
Spare parts

| | Dim. | Art.Nr. |
|-------------------------------|--------|----------------|
| Spannkeil - Clamping wedge | 40 | 707.430 |
| | 60 | 707.431 |
| | 80 | 707.432 |
| | 100 | 707.433 |
| | 130 | 707.435 |
| | 150 | 707.436 |
| | 180 | 707.437 |
| Ausgleichsstück - Blind wedge | 230 | 707.439 |
| | 40 | 707.330 |
| | 60 | 707.331 |
| | 80 | 707.332 |
| | 100 | 707.333 |
| | 130 | 707.334 |
| | 150 | 707.335 |
| Gewindestift - Screw | 180 | 707.336 |
| | 230 | 707.337 |
| | M12x20 | 705.556 |
| Sechskantschlüssel - T Wrench | M10x20 | 705.552 |
| | SW6 | 706.106 |

| H | D1 | | Pt max | |
|----|-------|-------|--------|--------|
| | D 122 | D 137 | HS | HW |
| 50 | 160 | 175 | 15 | 11/15* |
| 60 | 179 | 194 | 25 | 17/25* |
| 70 | 198 | 214 | 35 | 20/35* |

* System Mikroverzahnung
 * Microserrated system

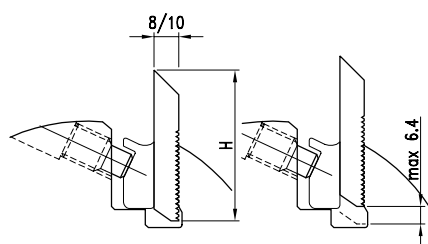
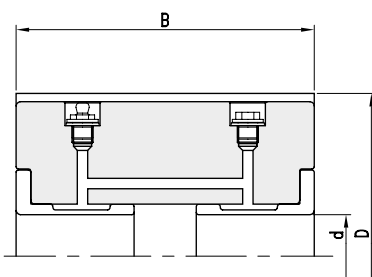

| H | D1 | | | | Pf max | |
|----|------|------|------|------|--------|--------|
| | D137 | D150 | D163 | D190 | HS | HW |
| 50 | 175 | 188 | 200 | 228 | 15 | 11/15* |
| 60 | 194 | 207 | 219 | 247 | 25 | 17/25* |
| 70 | 214 | 227 | 239 | 266 | 35 | 20/35* |

* System Mikroverzahnung

* Microserrated system

Hydro-Profilmesserkopf für rückenverzahnte Messer
Hydro-Profile cutterhead for serrated back blank knives
MEC
HW

| D | B | d | Z | n max | Art.Nr. |
|-----|-----|----|----|-------|--------------|
| 137 | 60 | 40 | 4 | 9000 | 2111.137.060 |
| | 100 | 40 | 4 | 9000 | 2111.137.100 |
| | 130 | 40 | 4 | 9000 | 2111.137.130 |
| | 150 | 40 | 4 | 9000 | 2111.137.150 |
| | 180 | 40 | 4 | 9000 | 2111.137.180 |
| | 230 | 40 | 4 | 9000 | 2111.137.230 |
| 150 | 60 | 50 | 4 | 8000 | 2111.150.060 |
| | 100 | 50 | 4 | 8000 | 2111.150.100 |
| | 130 | 50 | 4 | 8000 | 2111.150.130 |
| | 150 | 50 | 4 | 8000 | 2111.150.150 |
| | 180 | 50 | 4 | 8000 | 2111.150.180 |
| | 230 | 50 | 4 | 8000 | 2111.150.230 |
| 150 | 60 | 50 | 6 | 8000 | 2111.150.061 |
| | 100 | 50 | 6 | 8000 | 2111.150.101 |
| | 130 | 50 | 6 | 8000 | 2111.150.131 |
| | 150 | 50 | 6 | 8000 | 2111.150.151 |
| | 180 | 50 | 6 | 8000 | 2111.150.181 |
| | 230 | 50 | 6 | 8000 | 2111.150.231 |
| 163 | 60 | 50 | 8 | 6000 | 2111.150.060 |
| | 100 | 50 | 8 | 6000 | 2111.163.100 |
| | 130 | 50 | 8 | 6000 | 2111.163.130 |
| | 150 | 50 | 8 | 6000 | 2111.163.150 |
| | 180 | 50 | 8 | 6000 | 2111.163.180 |
| | 230 | 50 | 8 | 6000 | 2111.163.230 |
| 190 | 60 | 50 | 12 | 6000 | 2111.190.060 |
| | 80 | 50 | 12 | 6000 | 2111.190.080 |
| | 100 | 50 | 12 | 6000 | 2111.190.100 |
| | 130 | 50 | 12 | 6000 | 2111.190.130 |
| | 150 | 50 | 12 | 6000 | 2111.190.150 |
| | 180 | 50 | 12 | 6000 | 2111.190.180 |
| | 230 | 50 | 12 | 6000 | 2111.190.230 |

- Ohne RVZ Messer
- *Cutterhead without knives*
- Messerkopf aus Stahl mit offenem Hydrospannsystem.
- Hydrosystem als Zentrier-Spannsystem bei Betriebsdruck von ca. 300-400 bar (täglich kontrollieren).
- Ausführung für mechanischen Vorschub.
- *Steel-cutterhead with integrated, open hydroclamping system for greasepump.*
- *Hydrosystem as centering-clampingsystem for working pressure between 300 and 400bar (check daily). Layout for mechanical feed.*

Ersatzteile
Spare parts

| | Dim. | Art.Nr. |
|--|--------|---------|
| Spannkeil - Clamping wedge | 60 | 707.431 |
| | 100 | 707.433 |
| | 130 | 707.435 |
| | 150 | 707.436 |
| | 180 | 707.437 |
| | 230 | 707.439 |
| Ausgleichsstück - Blind wedge | 60 | 707.331 |
| | 100 | 707.333 |
| | 130 | 707.334 |
| | 150 | 707.335 |
| | 180 | 707.336 |
| | 230 | 707.337 |
| Gewindestift - Screw | M12x20 | 705.556 |
| | M10x20 | 705.552 |
| Sechskantschlüssel - T Wrench | SW6 | 706.106 |
| Fettpresse - Grease pump | | 724.401 |
| Fettkartusche - Grease cartridge | | 724.402 |
| Sicherheits-Klemmring für Maschinenspindel - Safety ring | | 724.404 |

2184
2189

SP Universal-Profilmesserkopf - Wechselsmesser
SP Universal profilecutter - Reversible knife

PG
02

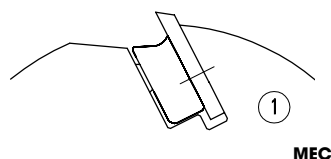

MEC

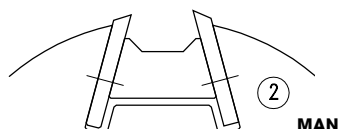

MAN

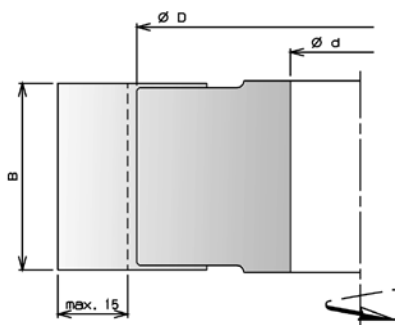

- Sondermesser und Abweiser auf Anfrage
- *Special knives and limiter available upon request.*

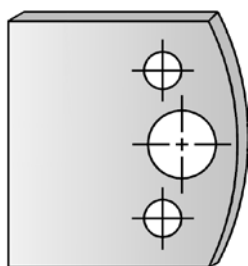

778.000 / 778.001

Typ 1 Universal-Profilmesserkopf mit Stahltragkörper für 40mm breite Profilmesser.
Type 1 Profile cutterhead with steel body to use 40mm profile knives.

MEC

HW

| D | B | d | Z | Messer | n max | Art.Nr. |
|---|----|----|---|------------------|-------|---------------------|
| Mit 2 Falzmessern - <i>With 2 rebate knives</i> | | | | | | |
| 100 | 40 | 30 | 2 | | 9000 | 2184.100.040 |
| 120 | 40 | 50 | 2 | | 9000 | 2184.120.040 |
| Kompletter Messersatz mit Holzkiste - <i>Set complete in wooden box</i> | | | | | | |
| 100 | 40 | 30 | 2 | 1-6 | 9000 | 2184.100.140 |
| | 40 | 30 | 2 | 1-12 | 9000 | 2184.100.240 |
| | 40 | 30 | 2 | 9/12/14/15/19/36 | 9000 | 2184.100.340 |
| 120 | 40 | 50 | 2 | 1-6 | 9000 | 2184.120.140 |
| | 40 | 50 | 2 | 1-12 | 9000 | 2184.120.240 |
| | 40 | 50 | 2 | 9/12/14/15/19/36 | 9000 | 2184.120.340 |

- Große Auswahl unterschiedlicher Standard-Profile verfügbar.
- Ausführung für mechanischen Vorschub
- *Wide selection of different standard-profiles available.*
- *Layout for mechanical feed.*

Typ 2 Universal-Profilmesserkopf mit Stahltragkörper für 40mm breite Profilmesser und Abweiser
Type 2 profile cutterhead with steel body to use 40mm profile knives and limitors

MAN

HW

| D | B | d | Z | Messer | n max | Art.Nr. |
|---|----|----|---|------------------|-----------|---------------------|
| Mit 2 Falzmessern - <i>With 2 rebate knives</i> | | | | | | |
| 100 | 40 | 30 | 2 | | 6000-9000 | 2189.100.040 |
| 120 | 40 | 50 | 2 | | 6000-9000 | 2189.120.040 |
| Kompletter Messersatz mit Holzkiste - <i>Set complete in wooden box</i> | | | | | | |
| 100 | 40 | 30 | 2 | 1-6 | 6000-9000 | 2189.100.140 |
| | 40 | 30 | 2 | 1-12 | 6000-9000 | 2189.100.240 |
| | 40 | 30 | 2 | 9/12/14/15/19/36 | 6000-9000 | 2189.120.340 |
| 120 | 40 | 50 | 2 | 1-6 | 6000-9000 | 2189.120.140 |
| | 40 | 50 | 2 | 1-12 | 6000-9000 | 2189.120.240 |
| | 40 | 50 | 2 | 9/12/14/15/19/36 | 6000-9000 | 2189.120.340 |

- Auswahl unterschiedlicher Standard-Profile verfügbar.
- Ausführung für manuellen Vorschub.
- *Wide selection of different standard-profiles available.*
- *Layout for manual feed*

Ersatzteile
Spare parts

| | Nr. | Dim. | Art.Nr. |
|---|-----|--------|----------------|
| Spannkeil - <i>Clamping wedge</i> | 1 | | 707.850 |
| | 2 | | 707.851 |
| Gewindestift - <i>Screw</i> | 1 | M10x20 | 705.552 |
| | 2 | M10x16 | 705.551 |
| Sechskantschlüssel - <i>T Wrench</i> | | SW5 | 706.105 |
| Messerrohling B=40 - <i>Knife for profiling B=40</i> | | | 778.000 |
| Abweiser-Rohling B=40 - <i>Limiter for profiling B=40</i> | | | 778.001 |
| Messerrohling B=50 - <i>Knife for profiling B=50</i> | | | 778.010 |
| Abweiser-Rohling B=50 - <i>Limiter for profiling B=50</i> | | | 778.011 |

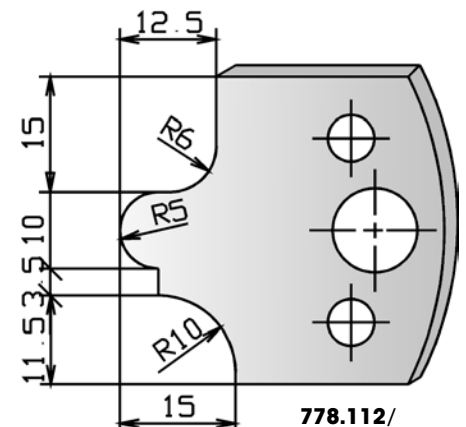
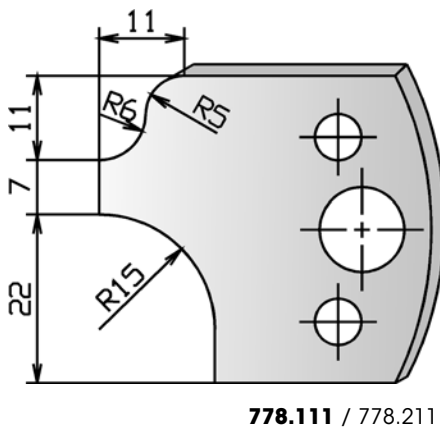
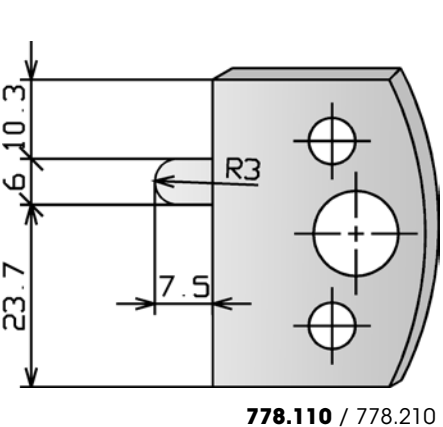
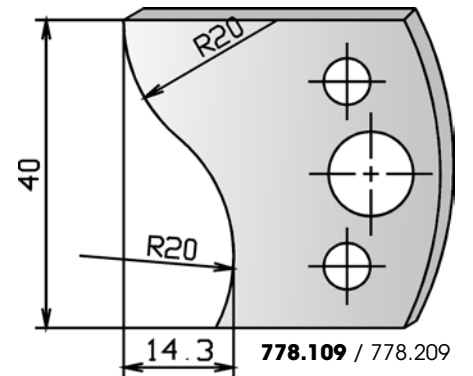
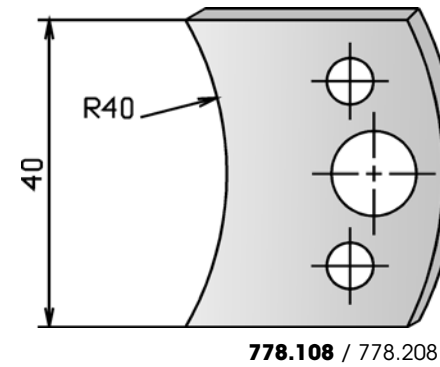
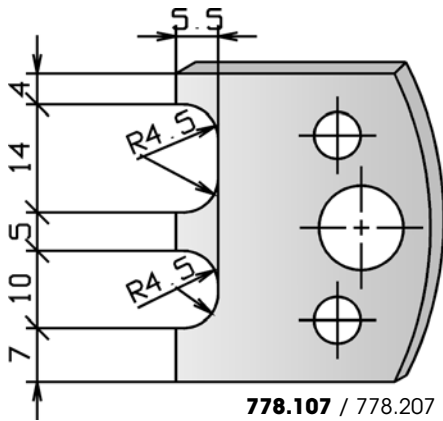
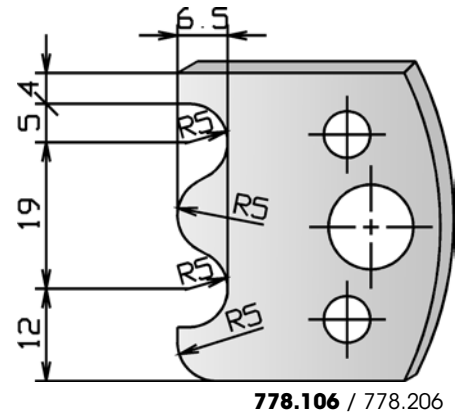
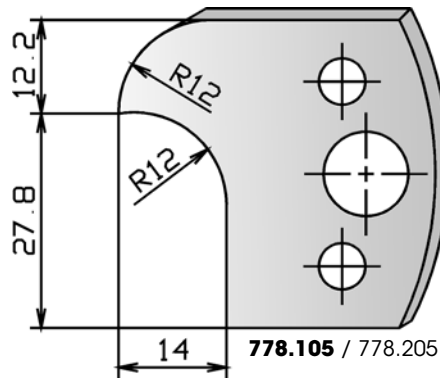
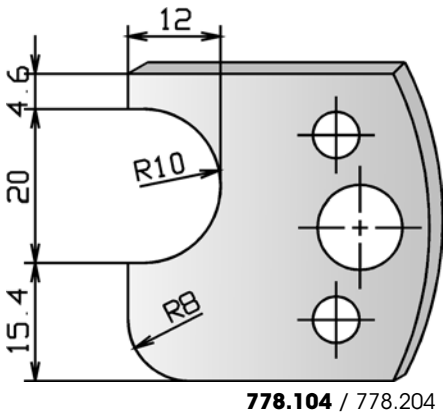
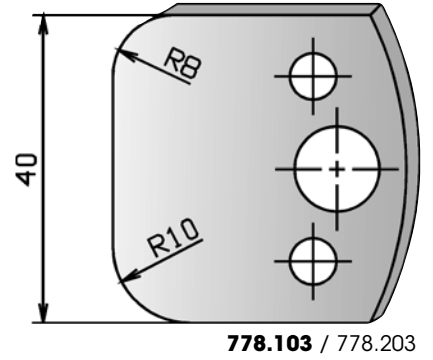
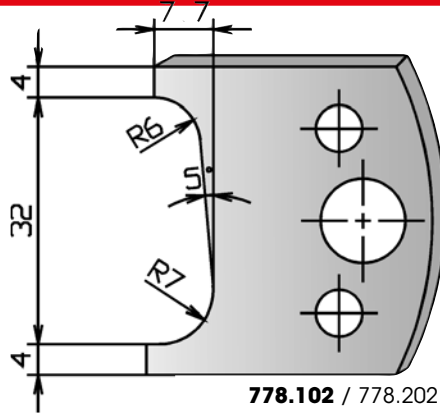
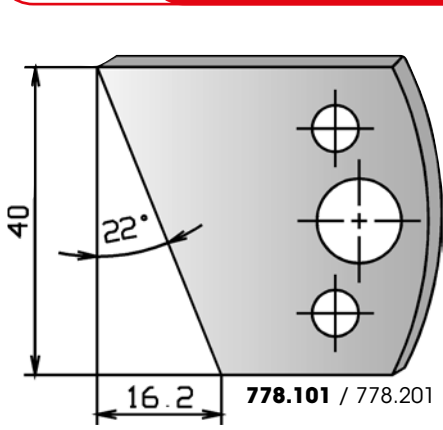

778.212

2184
2189

SP Universal-Profilmesserkopf - Profilmesserauswahl
SP Universal profilecutter - Profile knife options

PG
02

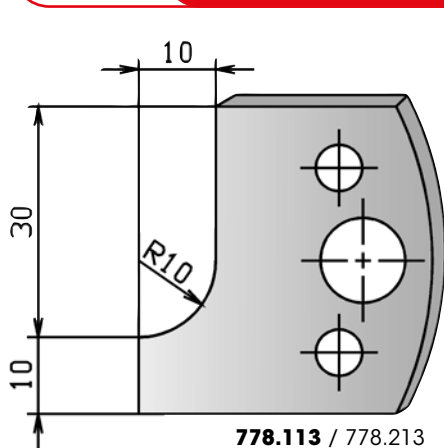

778.113 / 778.213

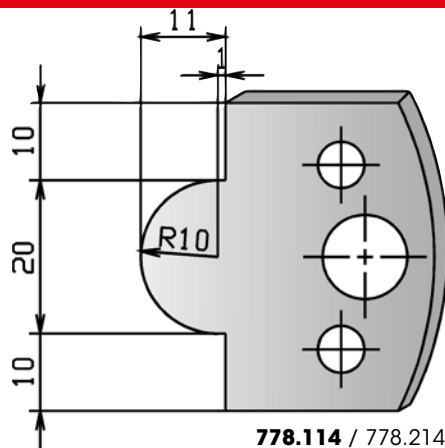

778.114 / 778.214

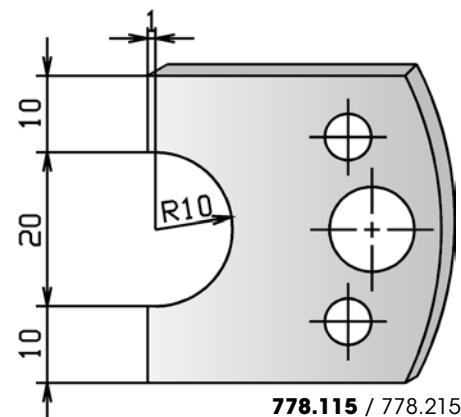

778.115 / 778.215

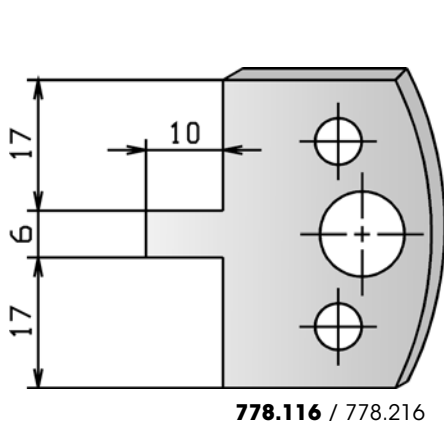

778.116 / 778.216

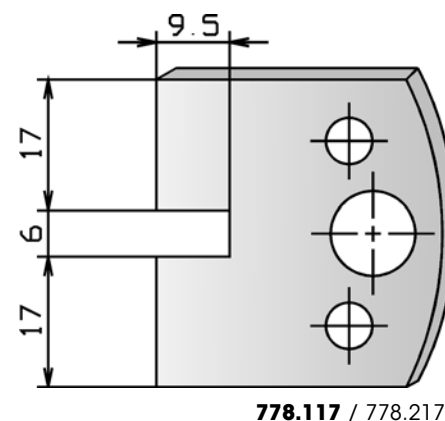

778.117 / 778.217

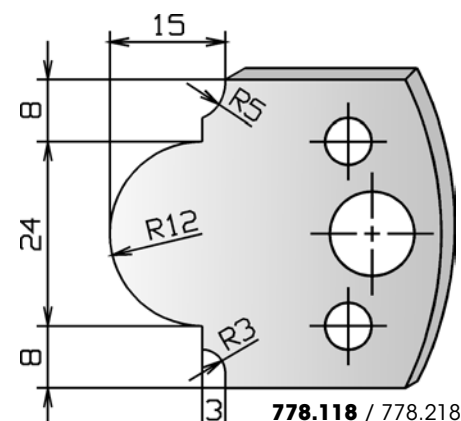

778.118 / 778.218

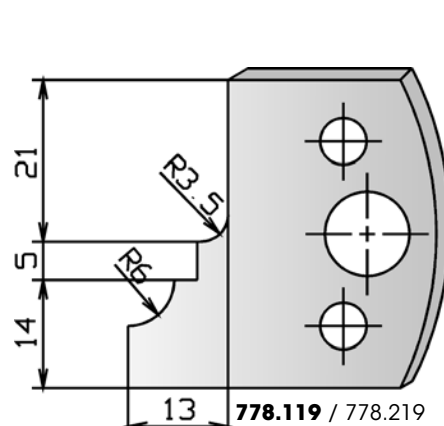

778.119 / 778.219

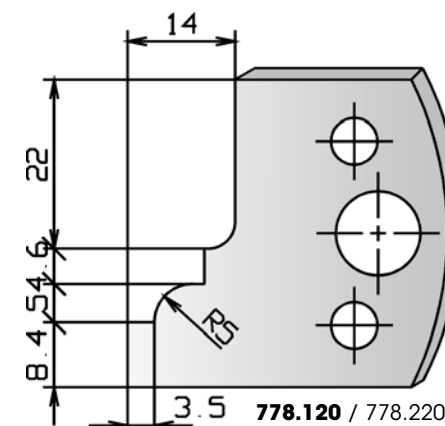

778.120 / 778.220

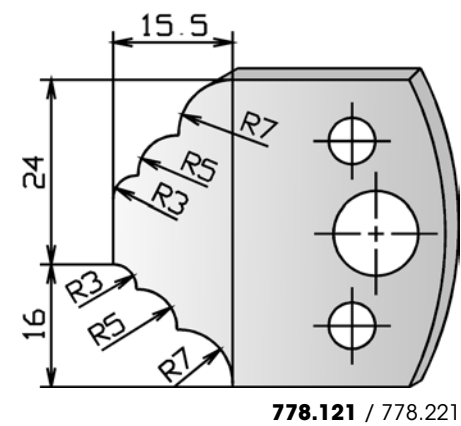

778.121 / 778.221

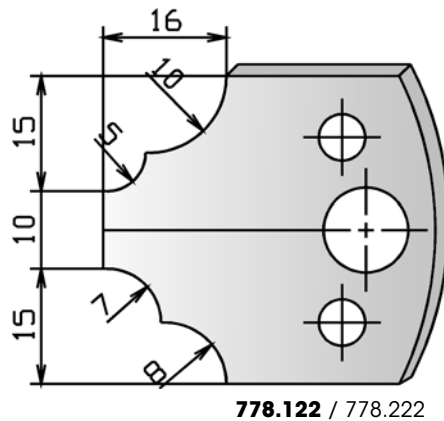

778.122 / 778.222

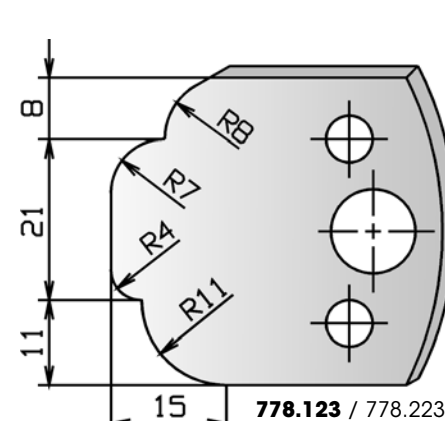

778.123 / 778.223

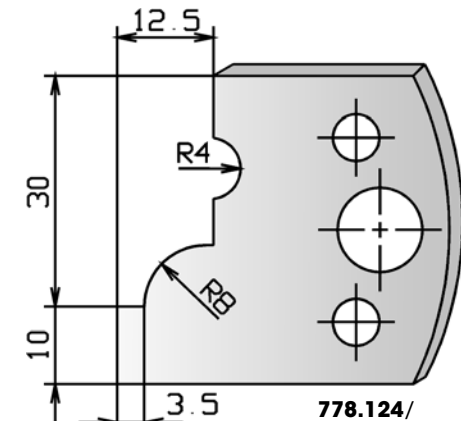

778.124 / 778.224

778.224



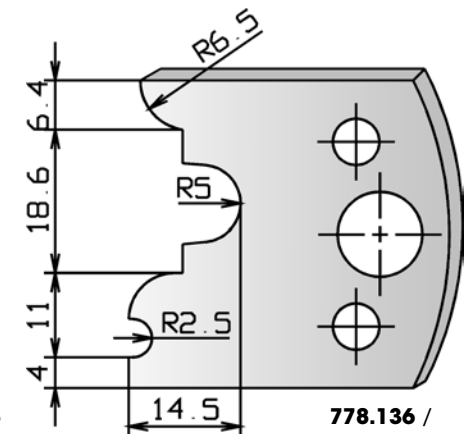
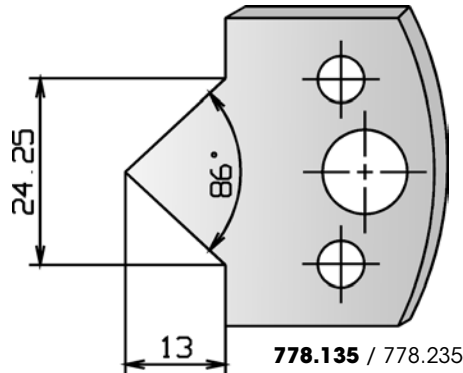
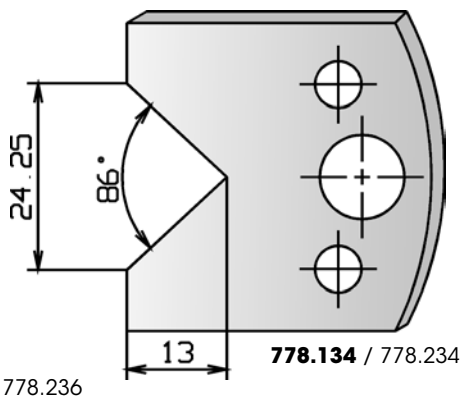
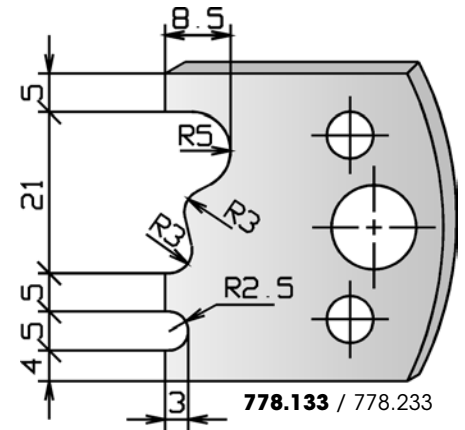
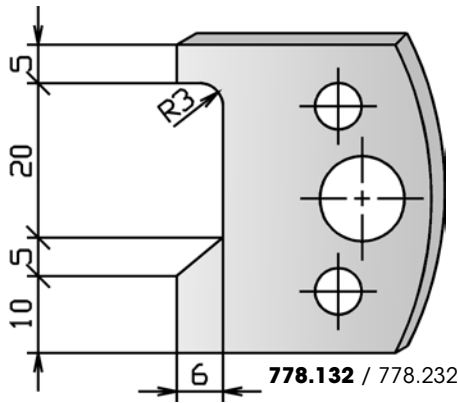
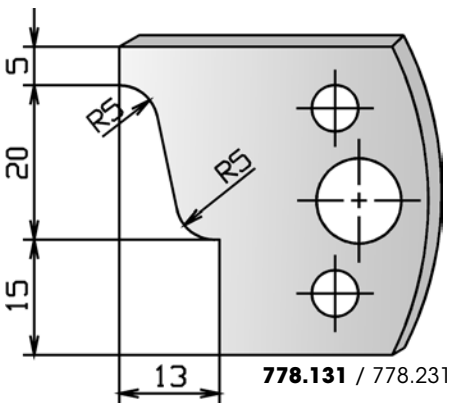
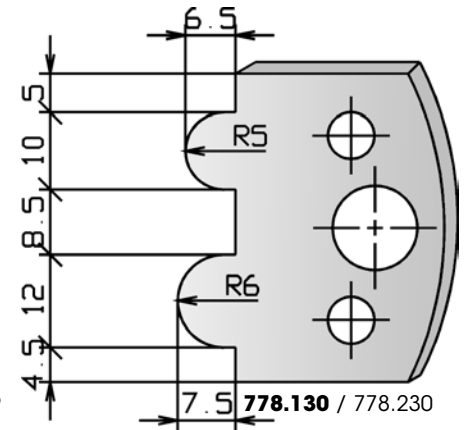
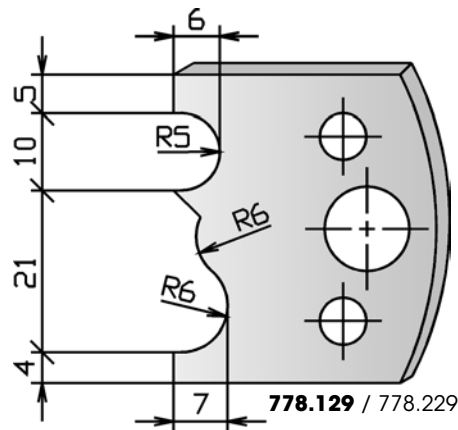
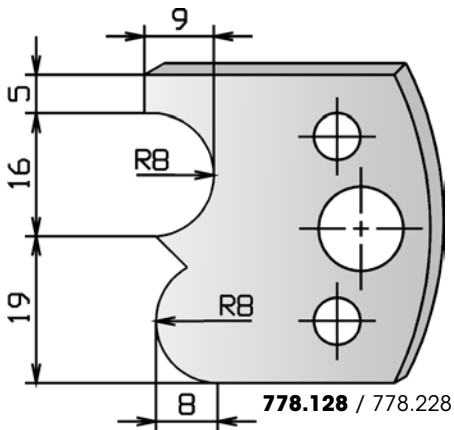
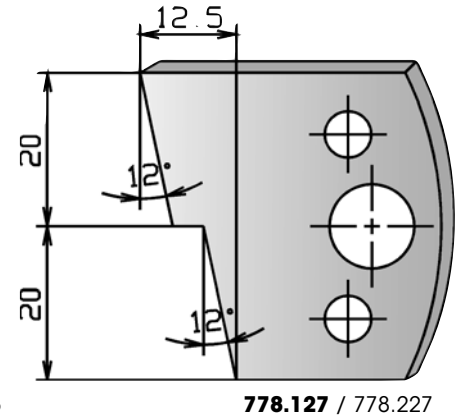
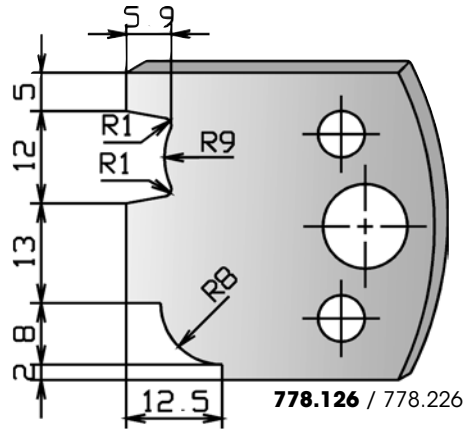
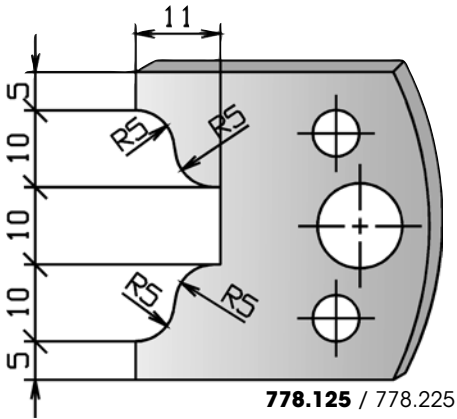

778.236

2184
2189

SP Universal-Profilmesserkopf - Profilmesserauswahl
SP Universal profilecutter - Profile knife options

PG
02

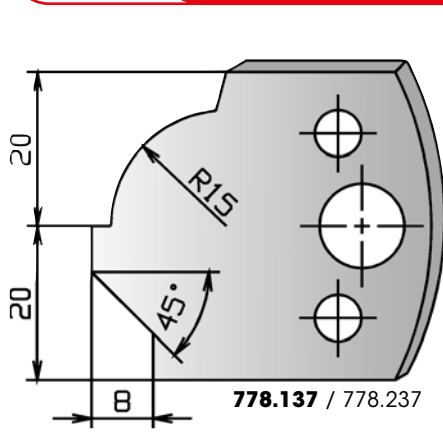

778.137 / 778.237

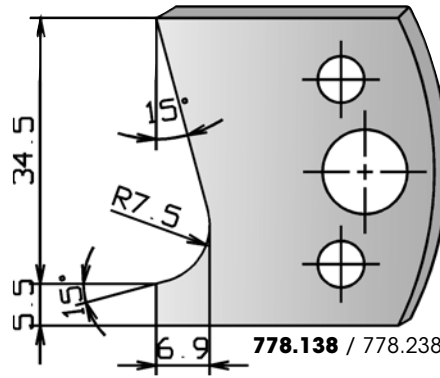

778.138 / 778.238

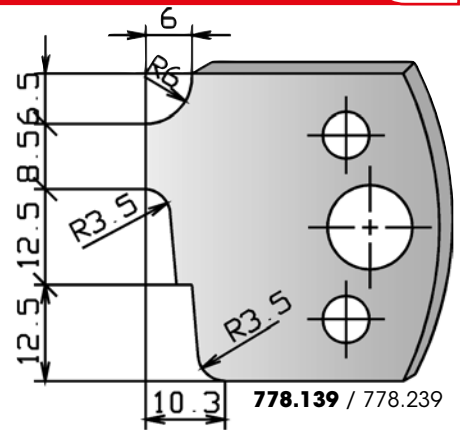

778.139 / 778.239

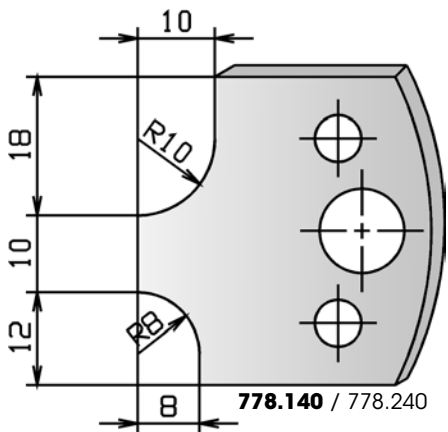

778.140 / 778.240

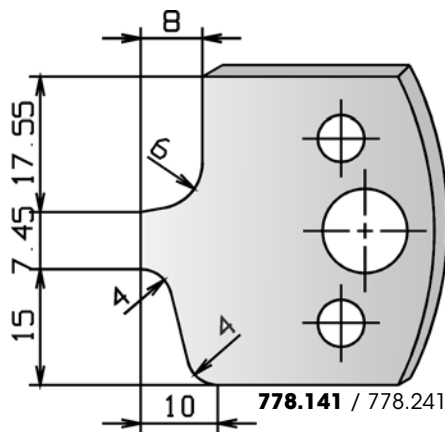

778.141 / 778.241

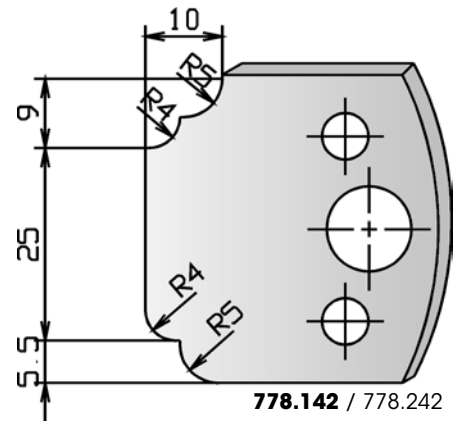

778.142 / 778.242

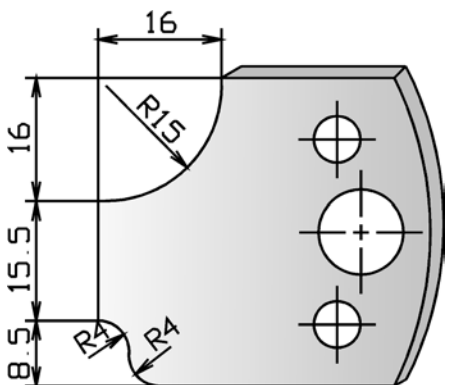

778.143 / 778.243

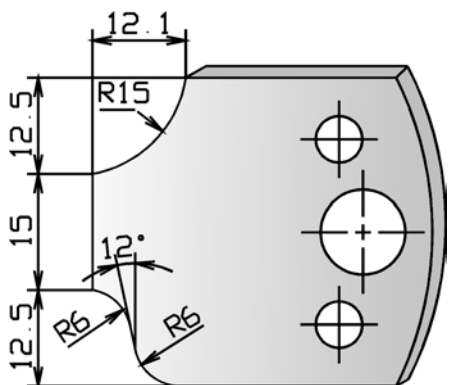

778.144 / 778.244

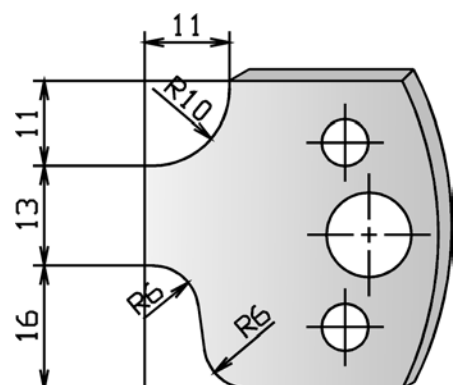

778.145 / 778.245

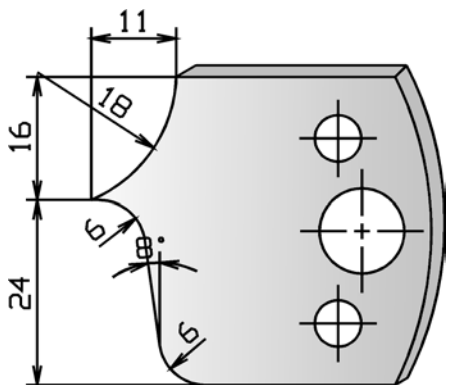

778.146 / 778.246

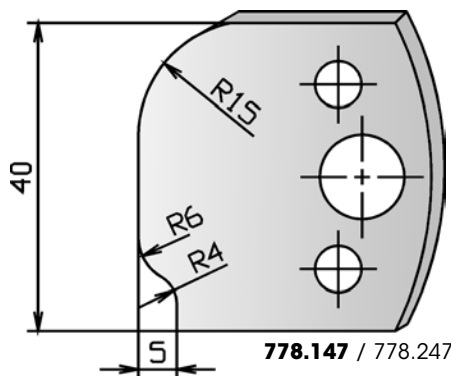

778.147 / 778.247

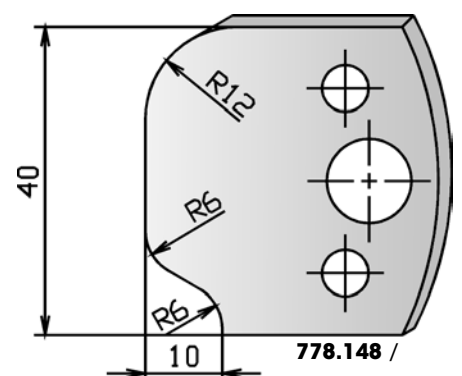

778.148 /

778.248



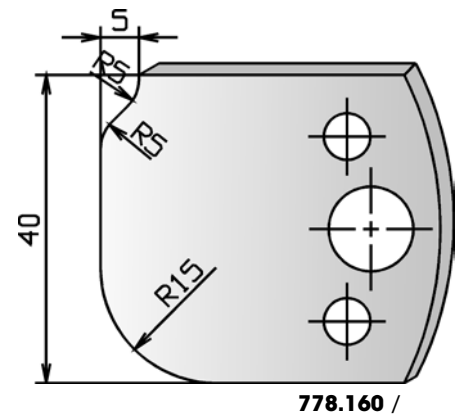
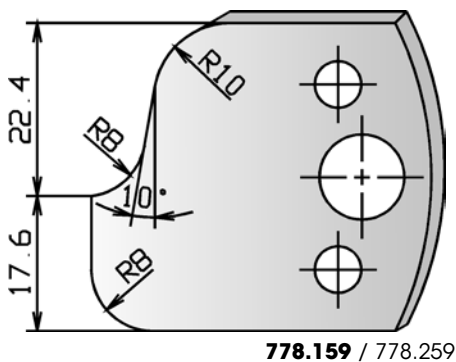
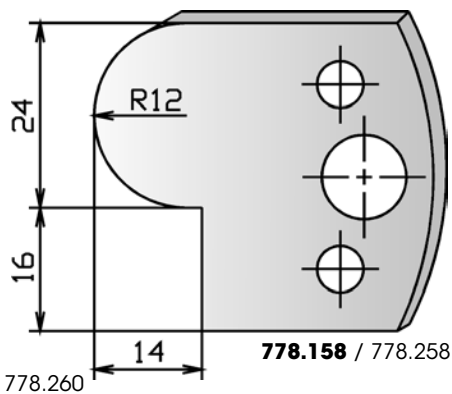
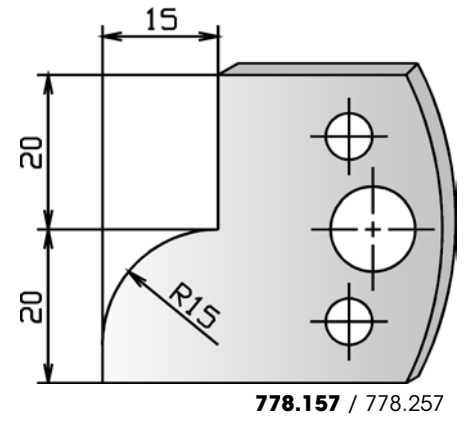
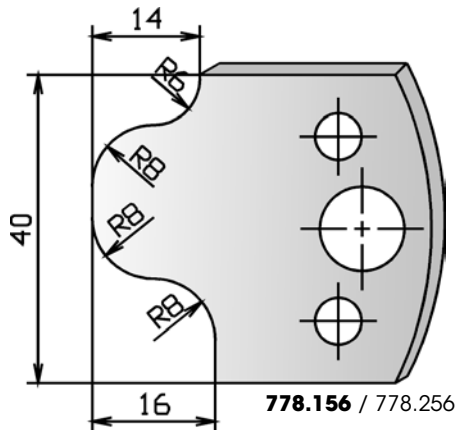
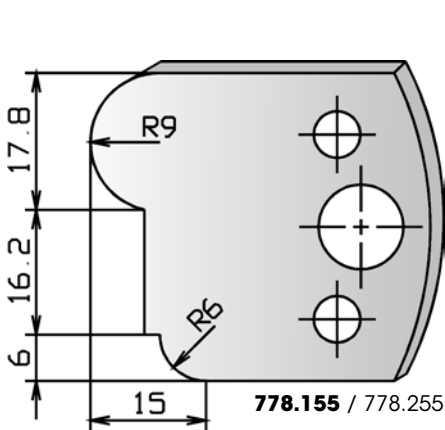
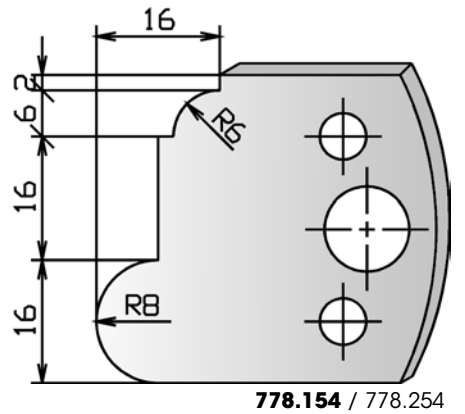
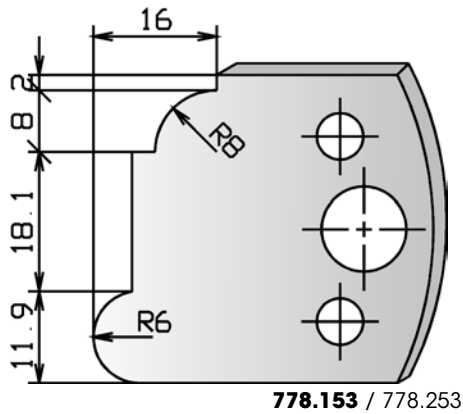
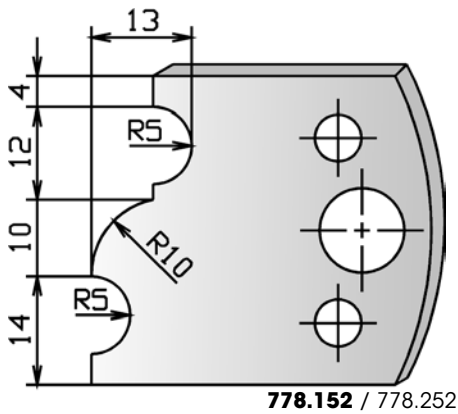
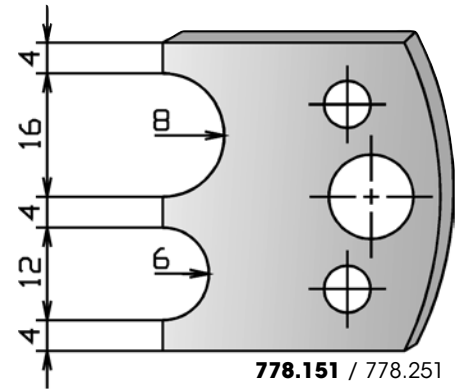
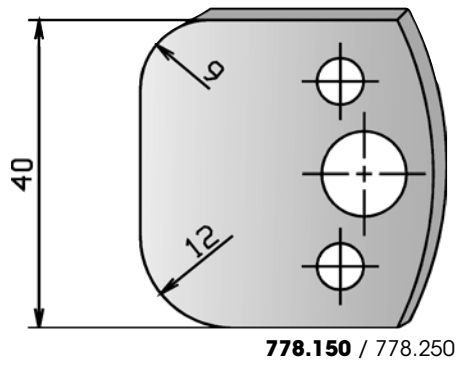
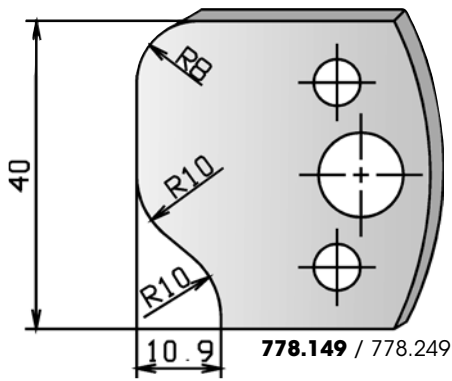

2184
2189

SP Universal-Profilmesserkopf - Profilmesserauswahl
SP Universal profilecutter - Profile knife options

PG
02

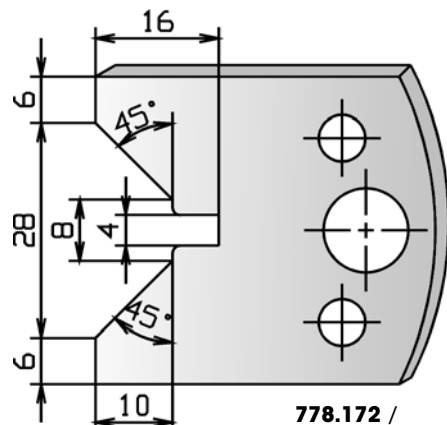
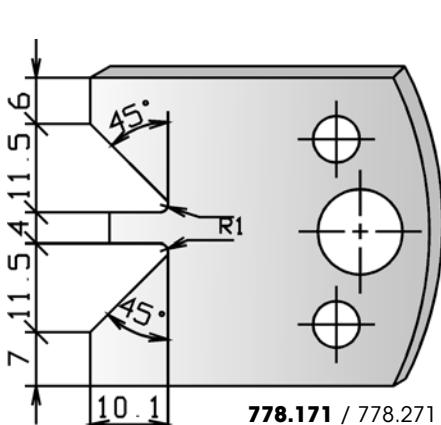
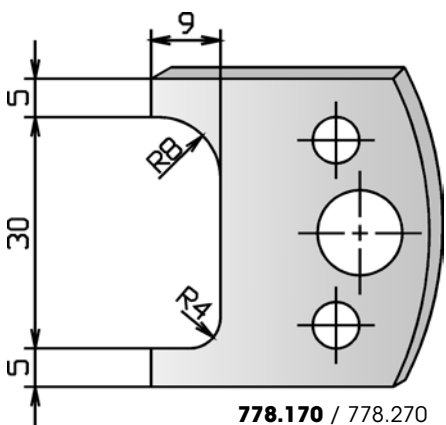
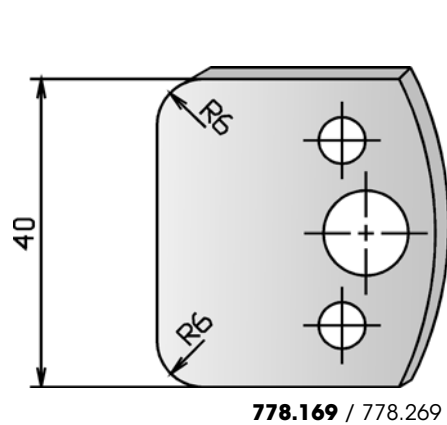
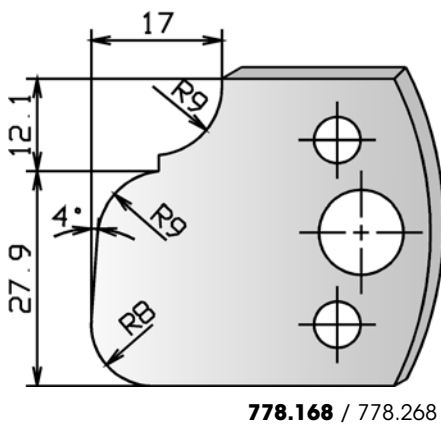
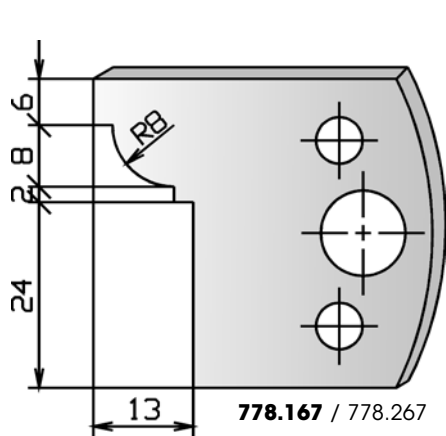
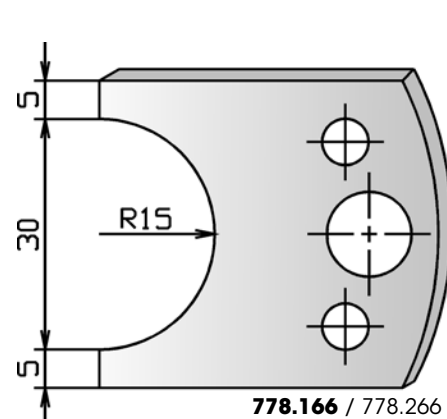
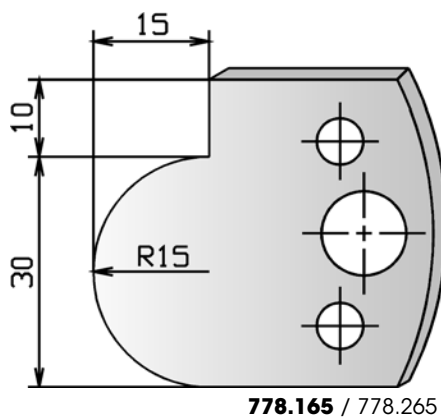
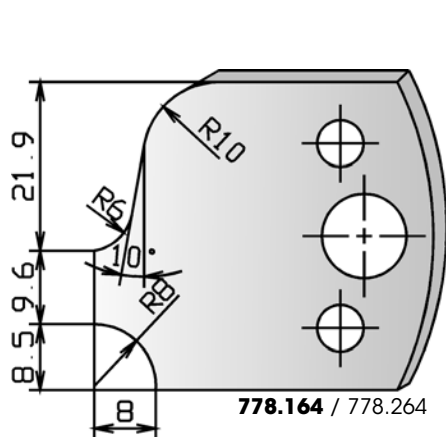
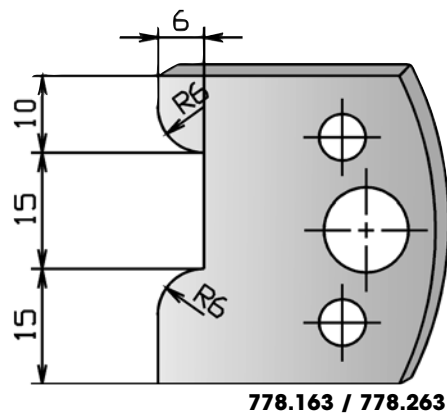
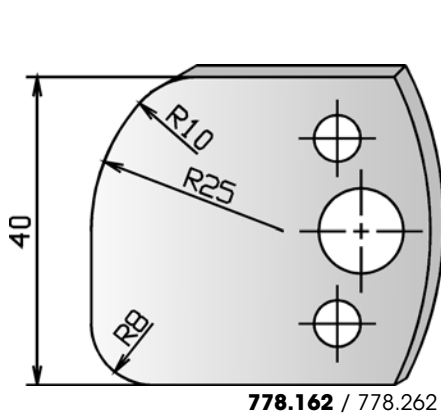
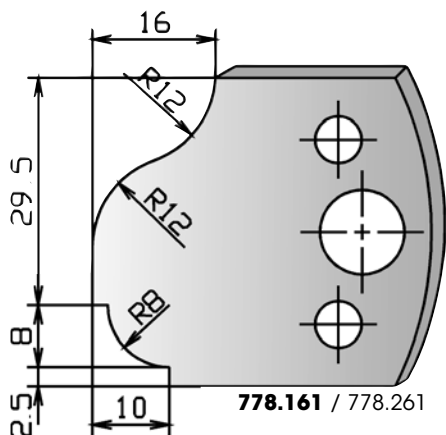

778.272



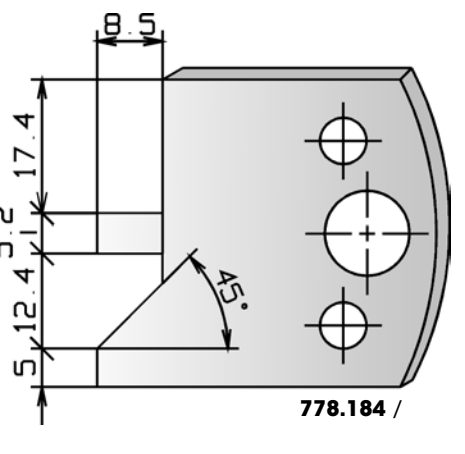
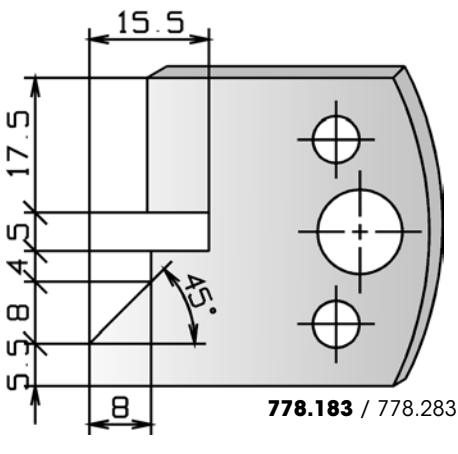
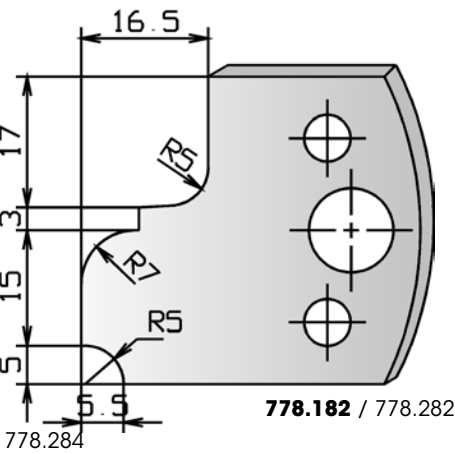
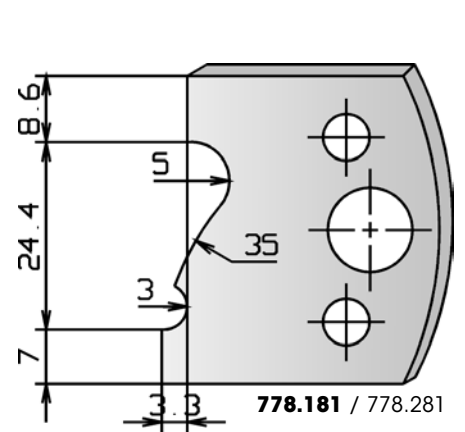
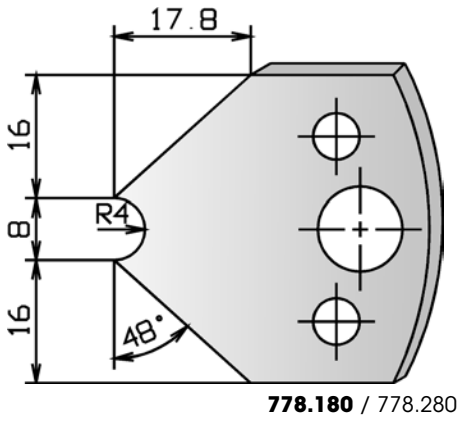
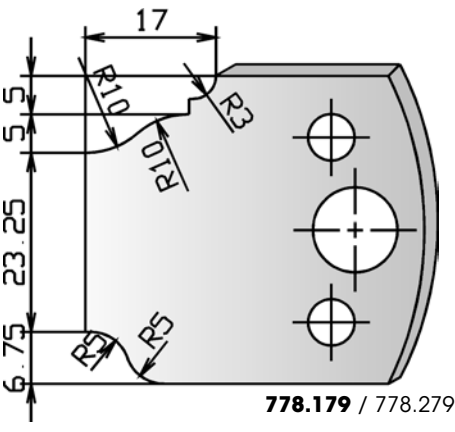
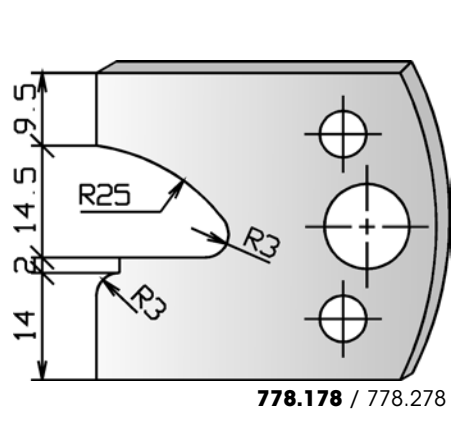
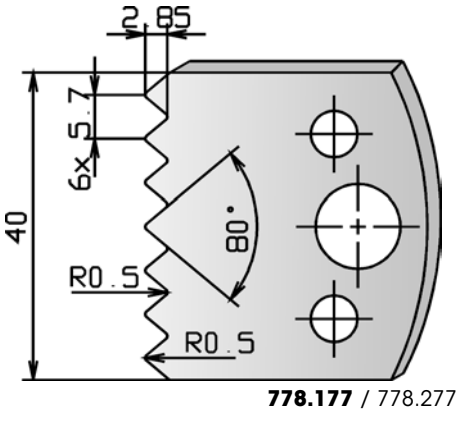
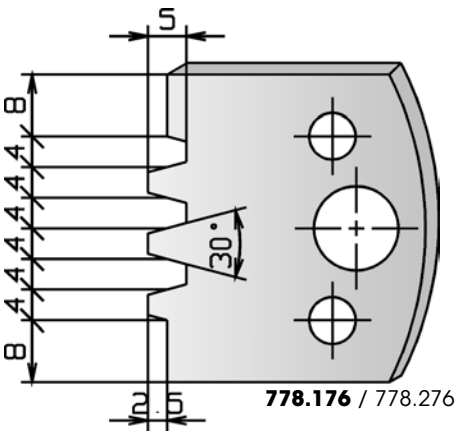
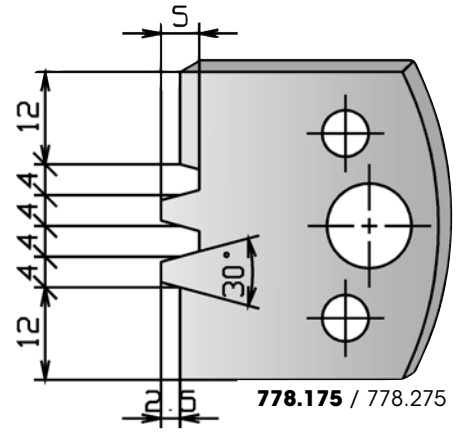
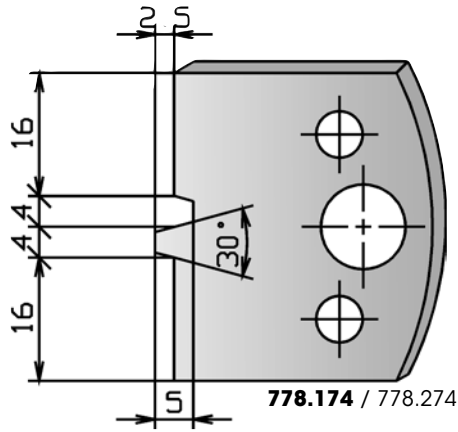
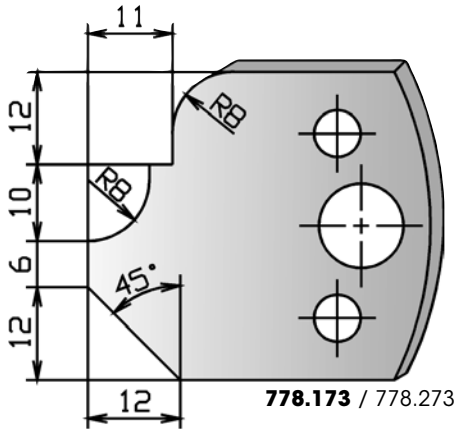

2184
2189

SP Universal-Profilmesserkopf - Profilmesserauswahl
SP Universal profilecutter - Profile knife options

PG
02

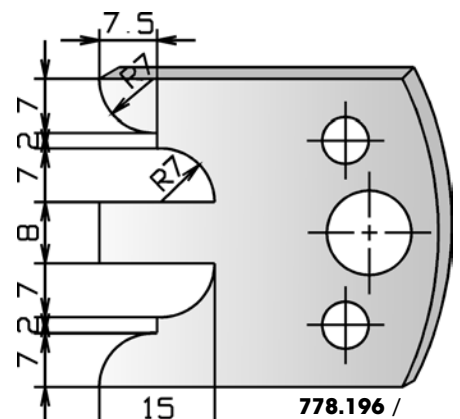
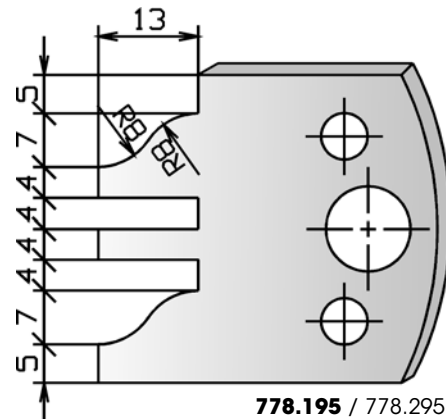
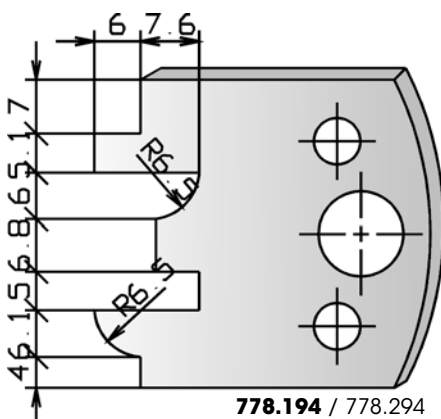
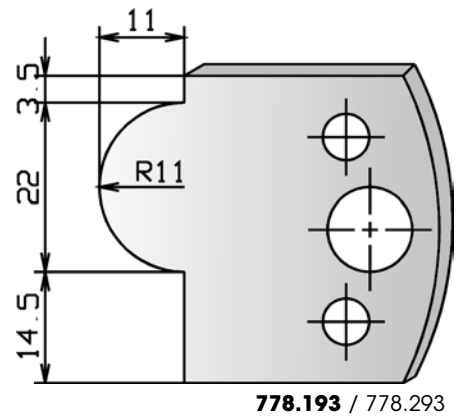
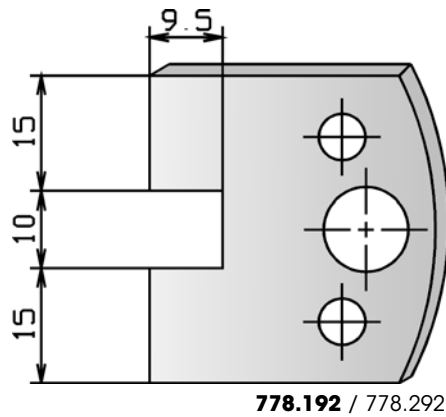
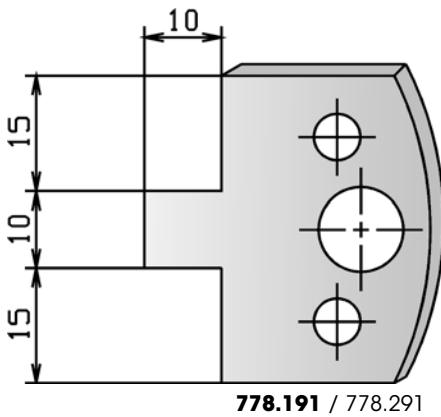
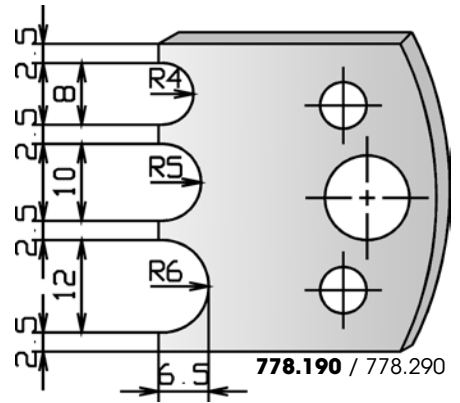
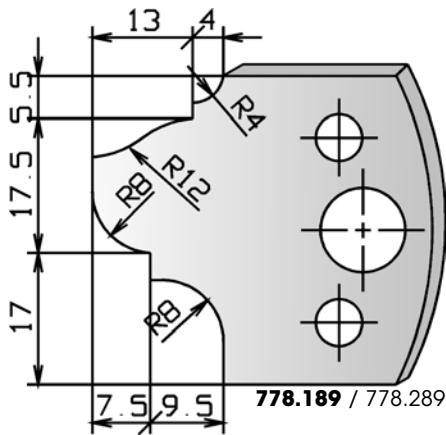
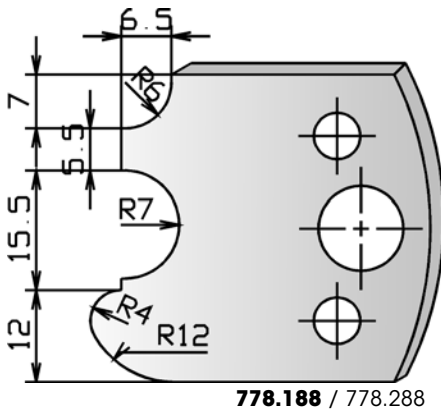
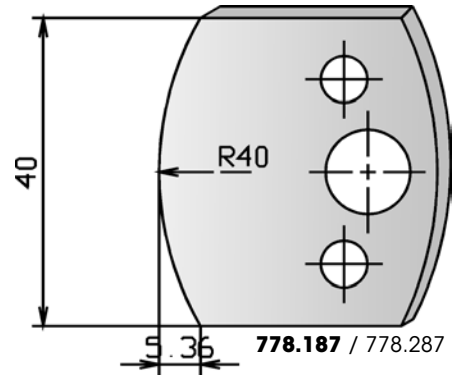
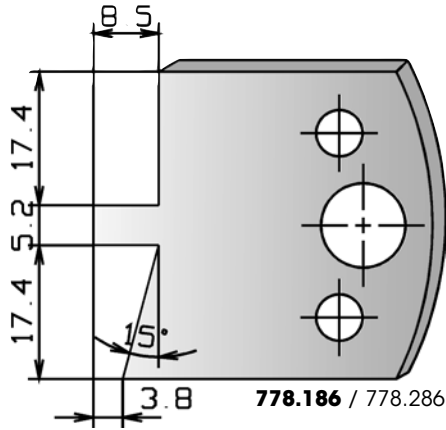
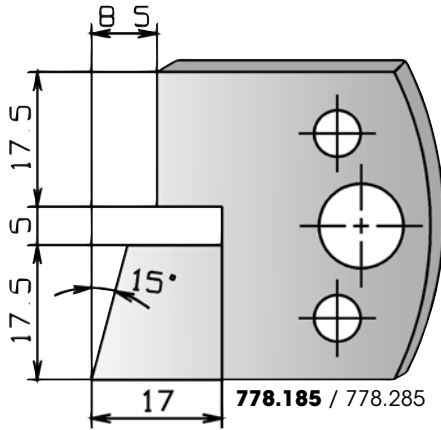

778.296



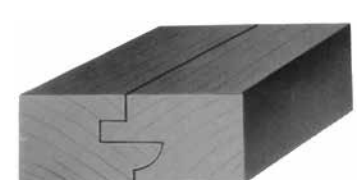
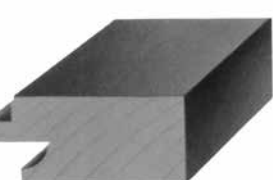
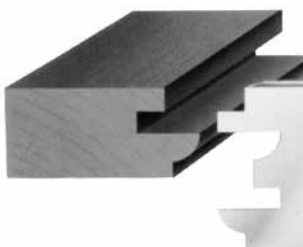
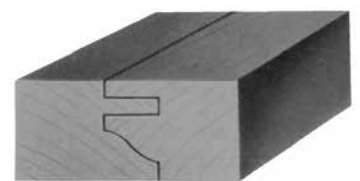
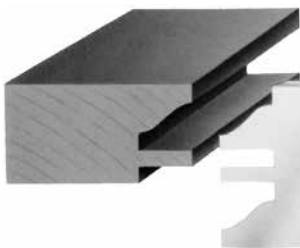
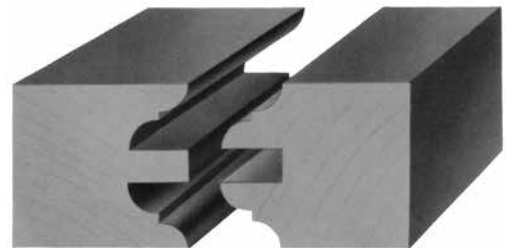
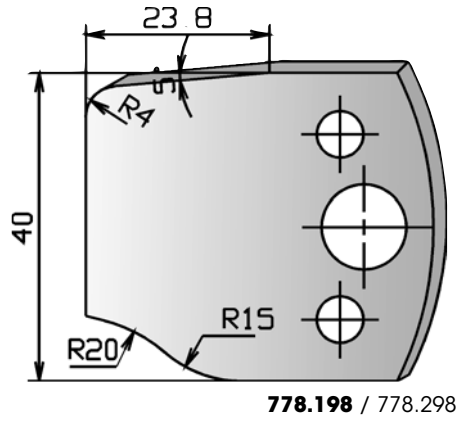
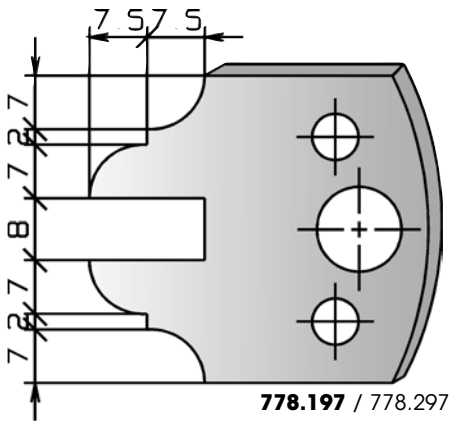



P1
 P1

MAN

HW

| Nr. | D | B | d | Z | n min - n max | Art.Nr. |
|-----|-----|----|----|---|---------------|---------------------|
| 1 | 140 | 12 | 50 | 3 | 5500-9500 | 8289.140.012 |
| 2 | | 13 | 50 | 3 | 5500-9500 | 8289.140.013 |

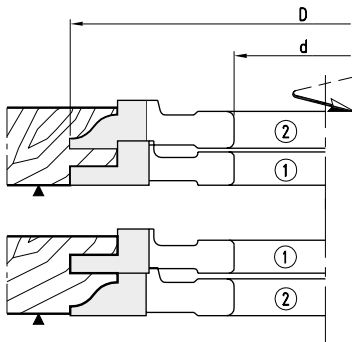
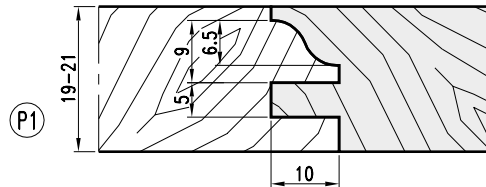
Garnitur - Cutterset (1+2)

8289.001.000
P2
 P2

MAN

HW

| Nr. | D | B | d | Z | n min - n max | Art.Nr. |
|-----|-----|----|----|---|---------------|---------------------|
| 1 | 140 | 12 | 50 | 3 | 5500-9500 | 8289.140.112 |
| 2 | | 13 | 50 | 3 | 5500-9500 | 8289.140.113 |

Garnitur - Cutterset (1+2)

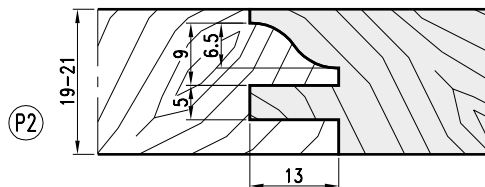
8289.002.000
P3
 P3

MAN

HW

| Nr. | D | B | d | Z | n min - n max | Art.Nr. |
|-----|-----|----|----|---|---------------|---------------------|
| 1 | 140 | 12 | 50 | 3 | 5500-9500 | 8289.140.212 |
| 2 | | 13 | 50 | 3 | 5500-9500 | 8289.140.014 |

Garnitur - Cutterset (1+2)

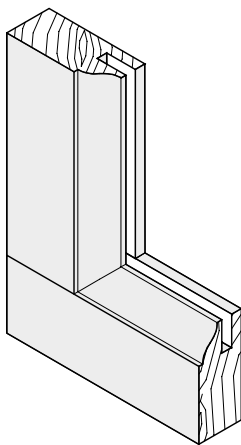
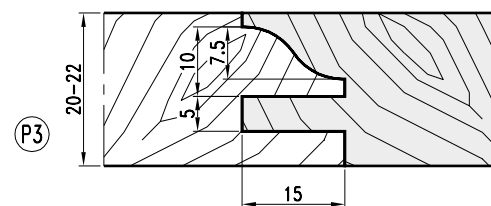
8289.003.000
P4
 P4

MAN

HW

| Nr. | D | B | d | Z | n min - n max | Art.Nr. |
|-----|-----|----|----|---|---------------|---------------------|
| 1 | 140 | 12 | 50 | 3 | 5500-9500 | 8289.140.312 |
| 2 | | 13 | 50 | 3 | 5500-9500 | 8289.140.213 |

Garnitur - Cutterset (1+2)

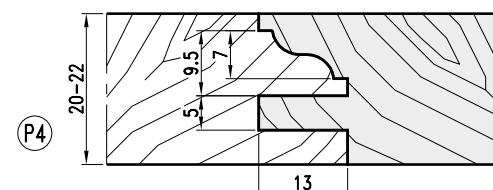
8289.004.000

- HW-Profilmesserkopf mit Stahltragkörper zum Fräsen von Profil- und Konterprofil an Massivholz-Rahmentüren.
- Auflistung 11 verschiedener Profilvarianten.
- Ausführung für manuellen Vorschub.
- TC-Profile tipped-cutterhead with steel tool body for profiles and counter profiles in solid wood framed doors in cabinetry
- 11 tool sets for frames with different profiles.
- Layout for manual feed.

P5
P5

MAN
HW

| Nr. | D | B | d | Z | n min - n max | Art.Nr. |
|----------------------------|-----|----|----|---|---------------|---------------------|
| 1 | 140 | 12 | 50 | 3 | 5500-9500 | 8289.140.112 |
| 2 | | 13 | 50 | 3 | 5500-9500 | 8289.140.313 |
| Garnitur - Cutterset (1+2) | | | | | | 8289.005.000 |

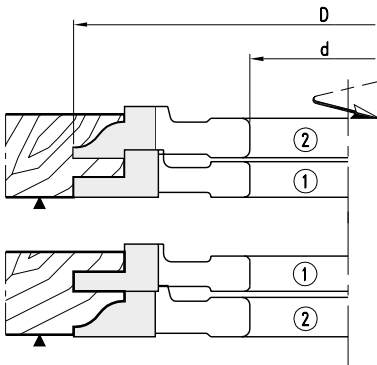
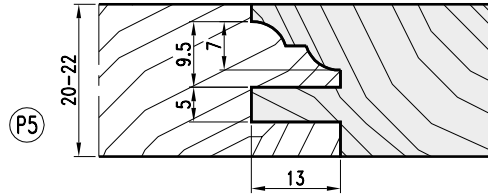
P6
P6

MAN
HW

| Nr. | D | B | d | Z | n min - n max | Art.Nr. |
|----------------------------|-----|----|----|---|---------------|---------------------|
| 1 | 140 | 12 | 50 | 3 | 5500-9500 | 8289.140.012 |
| 2 | | 13 | 50 | 3 | 5500-9500 | 8289.140.114 |
| Garnitur - Cutterset (1+2) | | | | | | 8289.006.000 |

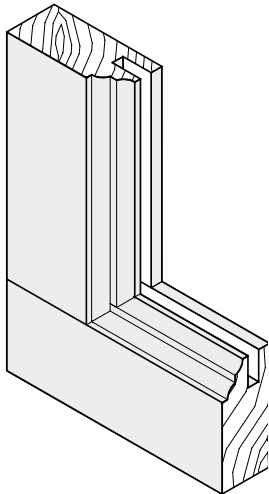
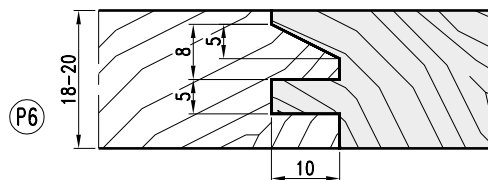
P7
P7

MAN
HW

| Nr. | D | B | d | Z | n min - n max | Art.Nr. |
|----------------------------|-----|----|----|---|---------------|---------------------|
| 1 | 140 | 12 | 50 | 3 | 5500-9500 | 8289.140.212 |
| 2 | | 13 | 50 | 3 | 5500-9500 | 8289.140.015 |
| Garnitur - Cutterset (1+2) | | | | | | 8289.007.000 |

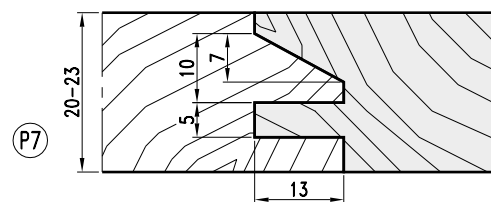

P8
P8

MAN
HW

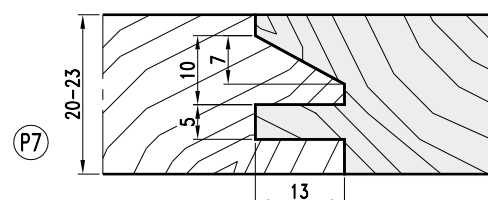
| Nr. | D | B | d | Z | n min - n max | Art.Nr. |
|----------------------------|-----|----|----|---|---------------|---------------------|
| 1 | 140 | 12 | 50 | 3 | 5500-9500 | 8289.140.312 |
| 2 | | 13 | 50 | 3 | 5500-9500 | 8289.140.115 |
| Garnitur - Cutterset (1+2) | | | | | | 8289.008.000 |

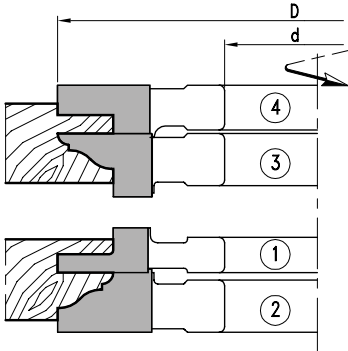

- HW-Profilmesserkopf mit Stahltragkörper zum Fräsen von Profil- und Konterprofil an Massivholz-Rahmentüren.
- Auflistung 11 verschiedener Profilvarianten.
- Ausführung für manuellen Vorschub.
- *TC-Profile tipped-cutterhead with steel tool body for profiles and counter profiles.*
- *11 tool sets for frames with different profiles.*
- *Layout for manual feed.*



P9
P9

MAN

HW

| Nr. | D | B | d | Z | n min - n max | Art.Nr. |
|----------------------------|-----|----|----|---|---------------|---------------------|
| 1 | 140 | 12 | 50 | 3 | 5500-9500 | 8289-140.212 |
| 2 | | 17 | 50 | 3 | 5500-9500 | 8289.140.017 |
| 3 | | 17 | 50 | 3 | 5500-9500 | 8289.140.117 |
| 4 | | 15 | 50 | 3 | 5500-9500 | 8289.140.215 |
| Garnitur - Cutterset (1+2) | | | | | | 8289.009.000 |
| Garnitur - Cutterset (3+4) | | | | | | 8289.009.001 |

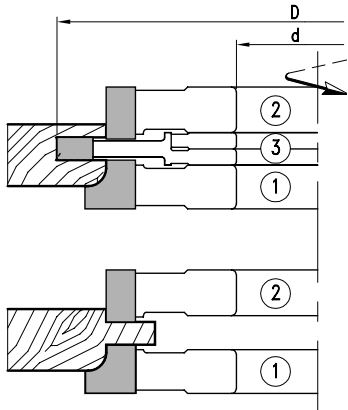
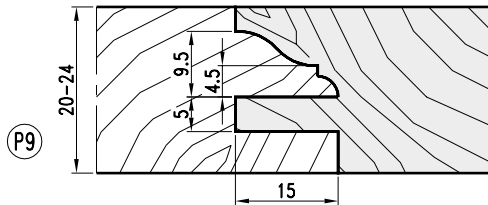

P10
P10

MAN

HW

| Nr. | D | B | d | Z | V | n min - n max | Art.Nr. |
|------------------------------|-----|--------|----|---|---|---------------------|---------------------|
| 1 | 143 | 10 | 50 | 3 | | 5300-9100 | 8289.143.010 |
| 2 | 130 | 16 | 50 | 3 | | 6000-10200 | 8289.130.016 |
| 3 | 160 | 7-13,5 | 50 | 4 | 4 | 4800-8300 | 8289.160.007 |
| Garnitur - Cutterset (1+2+3) | | | | | | 8289.010.000 | |

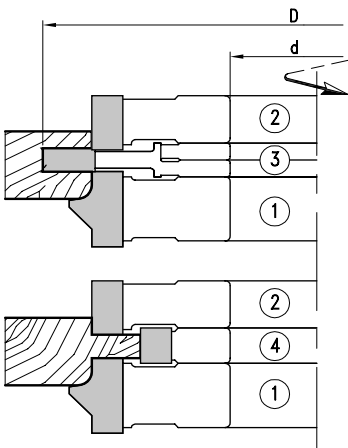
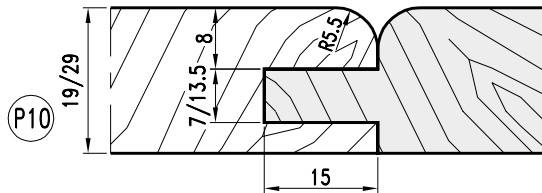

P11
P11

MAN

HW

| Nr. | D | B | d | Z | V | n min - n max | Art.Nr. |
|------------------------------|-----|--------|----|---|---|---------------------|---------------------|
| 1 | 143 | 22,5 | 50 | 3 | | 5300-9100 | 8289.143.023 |
| 2 | 130 | 16 | 50 | 3 | | 6000-10200 | 8289.130.116 |
| 3 | 160 | 7-13,5 | 50 | 4 | 4 | 4800-8300 | 8280.160.107 |
| 4 | 100 | 15 | 50 | 3 | | 7700-13300 | 8289.100.015 |
| Garnitur - Cutterset (1+2+3) | | | | | | 8289.011.000 | |

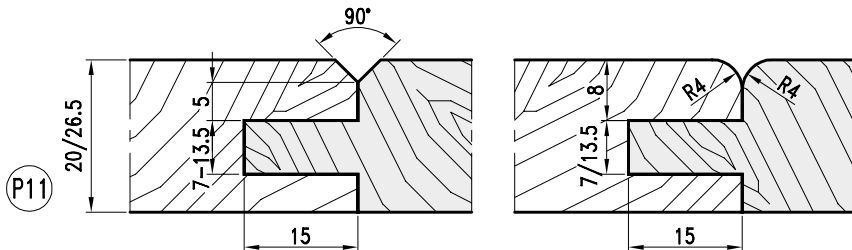

- HW-Profilmesserkopf mit Stahltragkörper zum Fräsen von Profil- und Konterprofil an Massivholz-Rahmentüren.
- Auflistung 11 verschiedener Profilvarianten.
- Ausführung für manuellen Vorschub.
- TC-Profile tipped-cutterhead with steel tool body for profiles and counter profiles in solid wood framed doors in cabinetry.
- 11 tool sets for frames with different profiles.
- Layout for manual feed.

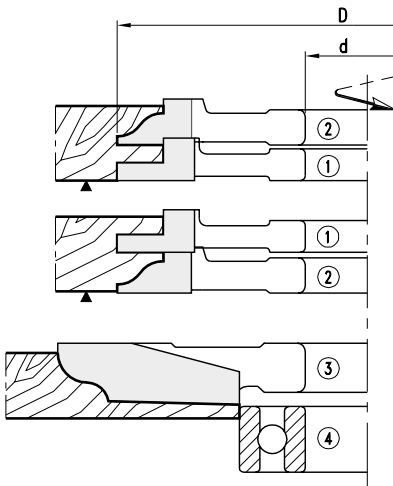
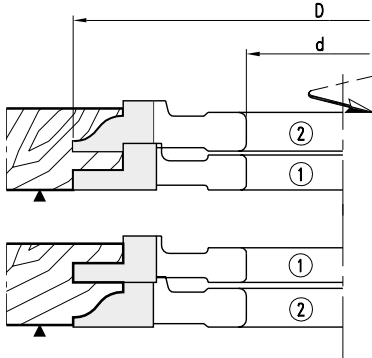

Türprofil- und Konterprofilgarnitur Z=3
Profile- and counterprofile cutterset for doors Z=3
MAN
HW

| Nr. | D | B | d | Z | n min - n max | Art.Nr. |
|----------------------------|-----|------|----|---|---------------|---------------------|
| 1 | 120 | 10,5 | 30 | 2 | 6400-11100 | 8289.120.011 |
| 2 | 120 | 11,8 | 30 | 2 | 6400-11100 | 8289.120.012 |
| Garnitur - Cutterset (1+2) | | | | | | 8289.012.000 |

- HW-Profilmesserkopf mit Stahltragkörper zum Fräsen von Profil und Konterprofil an Massivholz-Rahmentüren.
- Ausführungen für manuellen Vorschub.
- *TC-Profile tipped cutterhead with steel tool body for profiles and counter profiles in solid wood framed doors in cabinetry.*
- *Layout for manual feed.*

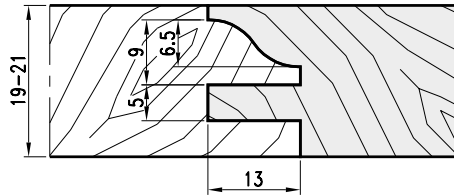
Türprofil- und Konterprofilgarnitur Z=2
Profile- and counterprofile cutterset for doors Z=2
MAN
HW

| Nr. | D | B | d | Z | n min - n max | Art.Nr. |
|--------------------------------|-----|------|----|---|---------------|---------------------|
| 1 | 120 | 10,5 | 30 | 2 | 6400-11100 | 8289.120.111 |
| 2 | 120 | 11,8 | 30 | 2 | 6400-11100 | 8289.120.112 |
| 3 | 150 | 14,0 | 30 | 2 | 5200-8900 | 8289.150.014 |
| 4 | 62 | | | | | 8289.062.000 |
| Garnitur - Cutterset (1+2+3+4) | | | | | | 8289.013.000 |

- HW-Profilmesserkopf mit Stahltragkörper zum Fräsen von Profil und Konterprofil, sowie zum Abplattieren von Füllungen mit Anlaufring.
- Ausführungen für manuellen Vorschub.
- *TC-Profile tipped cutterhead with steel body for profiles and counter profiles, and for panel raising with guide ring.*
- *Layout for manual feed.*

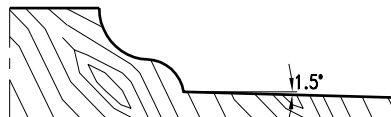
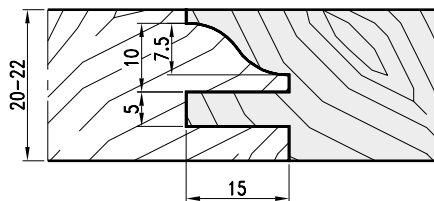



Türprofil- und Konterprofilgarnitur
Profile- and counterprofile cutterset for doors

MEC

HW

| Nr. | D | B | d | Z | n min - n max | Art.Nr. |
|----------------------|-----|----|-------|---|---------------|----------------|
| 1 | 165 | 30 | 30/50 | 2 | 5500-9500 | ● 4814.165.030 |
| 2 | 151 | 20 | 30/50 | 2 | 5500-9500 | ● 4814.151.020 |
| Garnitur - Cutterset | | | | | | 4814.000.000 |

- Ohne Wendemesser
- Cutterhead supplied without knives

- WP-Profilmesserkopf mit Stahlkörper zum Fräsen von Profil und Konterprofil an Massivholz-Rahmentüren. Vier verschiedene Profilvarianten.
- Ausführungen für mechanischen Vorschub.
- TC-Profile cutterhead with steel tool body and reversible knives for profiles and counter profiles in solid wood framed doors in cabinetry. Four tool sets for frames with different profiles.
- Layout for mechanical feed.

Wechselmesser/Ersatzteile
Reversible knives/Spare parts

| | Nr. | P | Dim. | Art.Nr. |
|----------------------------------|-----|----|---------|---------|
| Wechselmesser - Reversible knife | 1 | P1 | 30x35x2 | 785.790 |
| | | P2 | 30x35x2 | 785.791 |
| | | P3 | 30x35x2 | 785.792 |
| | | P4 | 30x35x2 | 785.793 |
| Spannkeil - Clamping wedge | 1 | | 20x30x2 | 785.794 |
| | 2 | | | 785.794 |
| Gewindestift - Screw | | | M8x16 | 705.542 |
| Sechskantschlüssel - T Wrench | | | SW4(M8) | 706.104 |

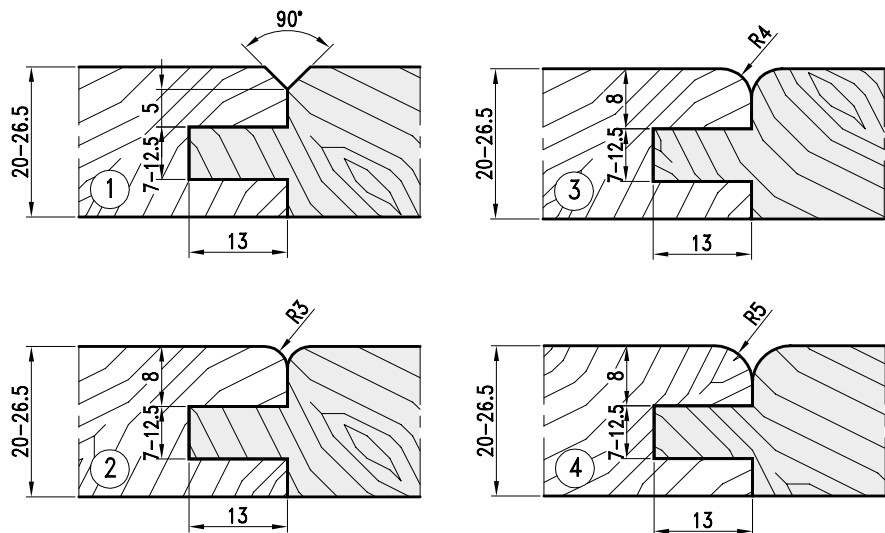
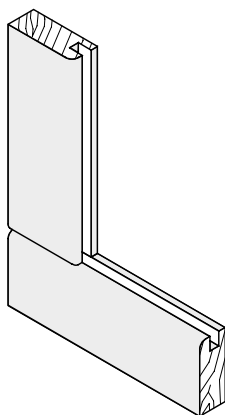
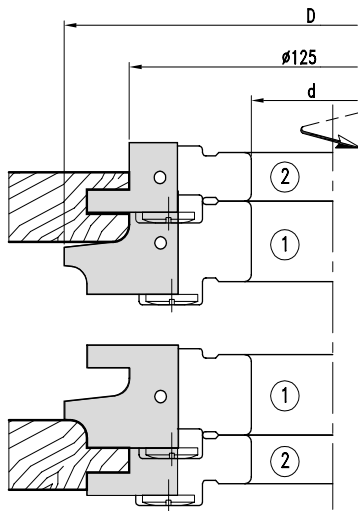

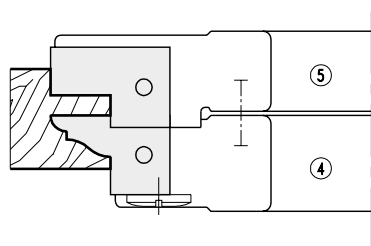
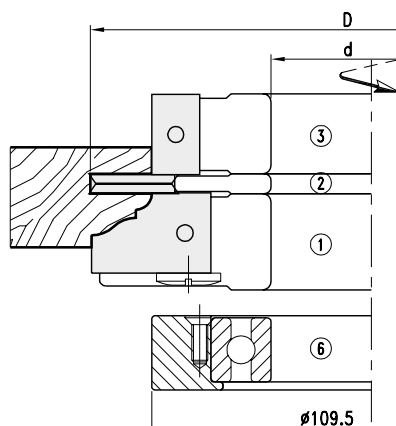

Türprofil- und Konterprofilgarnitur
Profile- and counterprofile cutterset

MAN

HW

| Nr. | D | B | d | Z | n min - n max | Art.Nr. |
|----------------------|-------|----------------------------|----|---|---------------|----------------|
| 1 | 139,5 | 20 | 50 | 4 | 5500-9500 | ● 4819.140.020 |
| 2 | 140,0 | 5 | 50 | 4 | 5500-9500 | 4849.140.005 |
| 3 | 109,5 | 20 | 50 | 4 | 7000-11900 | 4819.110.020 |
| 4 | 160,0 | 20 | 50 | 3 | 4800-8300 | ● 4819.160.020 |
| 5 | | 20 | 50 | 3 | 4800-8300 | 4819.160.120 |
| 6 | 109,5 | Anlaufring - Template ring | | | | 702.224 |
| Garnitur - Cutterset | | | | | | 4819.000.000 |

- Ohne Wechselmesser
- Cutterhead supplied without knives

- WP-Profilmesserkopf mit Stahltrgkörper zum Fräsen von Profil und Konterprofil an Massivholz-Rahmentüren mit Anlaufring. Drei verschiedene Profilvarianten.
- Ausführung für manuellen Vorschub.
- TC-Profile cutterhead with steel tool body and reversible knives for profiles and counter profiles in solid wood framed doors in cabinetry with guide ring in solid wood framed doors in cabinetry. Three tool sets for frames with different profiles.
- Layout for manual feed.

Wechselmesser/Ersatzteile
Reversible knives/Spare parts

| | Nr. | P | Dim. | Art.Nr. |
|----------------------------------|-----|----|----------|------------|
| Wechselmesser - Reversible knife | 1 | P1 | 20x30x2 | 785.750 |
| | | P2 | 20x30x2 | 785.751 |
| | | P3 | 20x30x2 | 785.752 |
| | 3 | | 20x12x15 | 750.102 |
| | 4 | P1 | 20x30x2 | 785.753 |
| | | P2 | 20x30x2 | 785.754 |
| | | P3 | 20x30x2 | 785.755 |
| Spannkeil - Clamping wedge | 5 | | 20x30x2 | 785.756 |
| | 1 | | | 707.091 |
| | 3 | | | 707.130.20 |
| | 4 | | | 707.092 |
| | 5 | | | 707.093 |
| Gewindestift - Screw | | | M8x16 | 705.542 |
| Kugellager - Ball bearing | 6 | | D-80 | 701.105 |
| Sechskantschlüssel - T Wrench | | | SW4 | 706.104 |

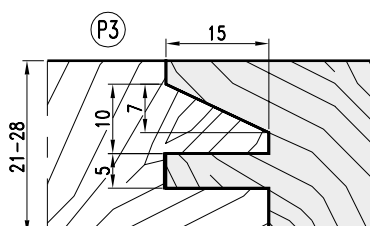
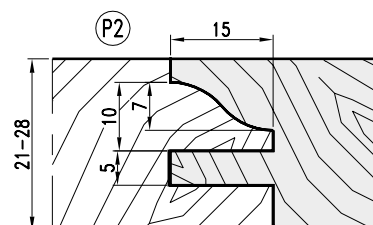
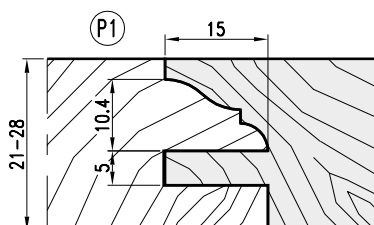



Türprofil- und Konterprofilgarnitur
Profile- and counterprofile cutterset

MAN

HW

| Nr. | D | B | d | Z | V | l | n min - n max | Art.Nr. |
|----------------------|-------|------|-------|---|-----|---|---------------|---------------------|
| 1 | 150,2 | 24,0 | 30/50 | 2 | 2+2 | 2 | 5200-8900 | 4819.150.024 |
| 2 | 150,0 | 29,5 | 30/50 | 2 | | | 5200-8900 | 4819.150.030 |
| Garnitur - Cutterset | | | | | | | | 4819.000.001 |

- WP-Profilmesserkopf mit Stahltrgkörper zum Fräsen von Profil und Konterprofil an Massivholz-Rahmentüren. Drei verschiedene Profilvarianten.
- Ausföhrung für manuellen Vorschub.
- TC-Profile cutterhead with steel tool body and reversible knives for profiles and counter profiles in solid framed doors in cabinetry. Three tool sets for frames with different profiles.
- Layout for manual feed.

Wechselmesser/Ersatzteile
Reversible knives/Spare parts

| | Nr. | P | Dim. | Art.Nr. |
|----------------------------------|-----|----|-------------|-------------------|
| Wechselmesser - Reversible knife | 2 | P1 | 29,5X27,5X2 | 785.404 |
| | | P2 | 29,5X27,5X2 | 785.405 |
| | | P3 | 29,5X27,5X2 | 785.406 |
| Spannkeil - Clamping wedge | 1 | P4 | 20x12x1,5 | 750.102 |
| | 2 | | | 707.253 |
| | 1 | | | 707.002.18 |
| Gewindestift - Screw | | | M8x16 | 705.542 |
| Vorschneider - Spur | | | 22x19x2 | 760.101 |
| Spannschraube - Screw | | | M5x8 | 705.422 |
| Nutmesser - Groover | | | 13x24,5x5 | 783.102 |
| Schraube - Screw | | | M5x13,5 | 705.318 |
| Sechskantschlüssel - T Wrench | | | SW3(M5) | 706.103 |
| | | | SW4(M8) | 706.104 |

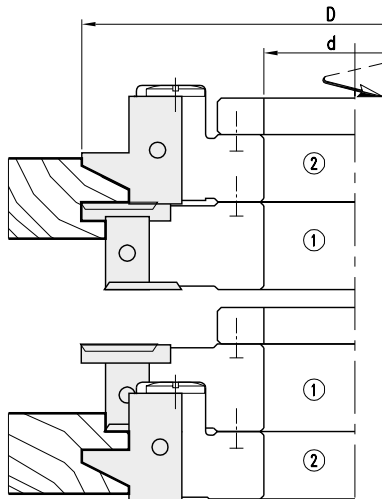

- Garnitur Art. 4819.000.001 wird vollständig mit 3 Profilen geliefert
- Cutterset 4819.000.001 supplied complete with 3 profiles

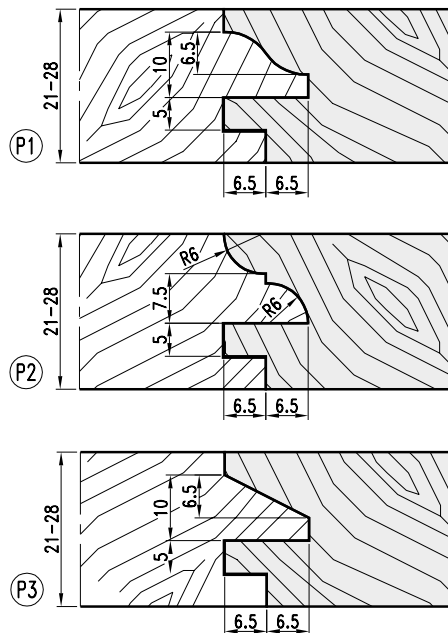
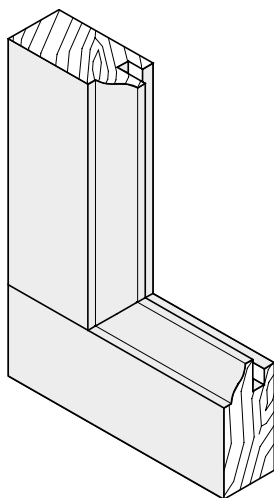

Türprofil- und Konterprofilgarnitur
Profile- and counterprofile cutterset
MAN
HW

| Nr. | D | B | d | Z | l | n min - n max | Art.Nr. |
|----------------------|-----|----|-------|---|---|---------------|-----------------------|
| 1 | 160 | 20 | 30/50 | 3 | 3 | 5500-9500 | ● 4819.160.030 |
| 2 | | 20 | 30/50 | 4 | | 5500-9500 | 4849.160.220 |
| 3 | 138 | 20 | 30/50 | 4 | | 7000-11900 | 4819.138.020 |
| Garnitur - Cutterset | | | | | | | 4819.000.002 |

- Ohne Wechselmesser
- Cutterhead supplied without knives

- WP-Profilmesserkopf mit Stahltrgkörper zum Fräsen von Profil und Konterprofil an Massivholz-Rahmentüren. Drei verschiedene Profilvarianten.
- Ausführung für manuellen Vorschub.
- TC-Profile cutterhead with steel tool body and reversible knives for profiles and counter profiles in solid wood framed doors in cabinetry. Three tool sets for frames with different profiles.
- Layout for manual feed.

Wechselmesser/Ersatzteile
Reversible knives/Spare parts

| | Nr. | P | Dim. | Art.Nr. |
|----------------------------------|-----|----|-----------|-------------------|
| Wechselmesser - Reversible knife | 1 | P1 | 30x25x2 | 785.302 |
| | | P2 | 30x25x2 | 785.301 |
| | | P3 | 30x25x2 | 785.303 |
| Spannkeil - Clamping wedge | 2/3 | | 20x12x1,5 | 750.102 |
| | 1 | | | 707.807 |
| Gewindestift - Screw | 2/3 | | | 707.002.18 |
| | 1 | | M8x12 | 705.541 |
| Vorschneider - Spur | 2/3 | | M8x16 | 705.542 |
| | 1 | | 22x19x2 | 760.101 |
| Spannschraube - Screw | 2 | | 14x14x2 | 750.111 |
| | | | M5x8 | 705.422 |
| Nutmesser - Groover | | | 35x17x5 | 783.121 |
| Schraube - Screw | | | M5x13,5 | 705.318 |
| Sechskantschlüssel - T Wrench | | | SW3(M5) | 706.103 |
| | | | SW4(M8) | 706.104 |

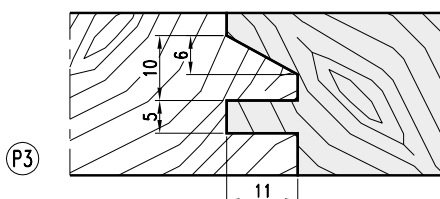
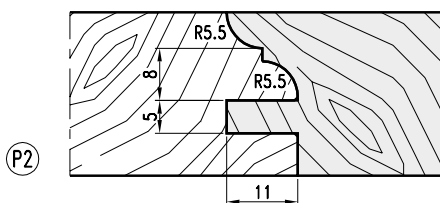
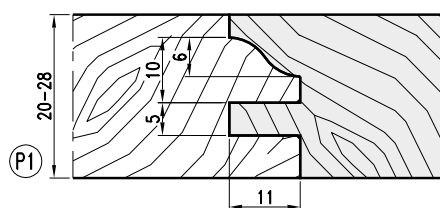
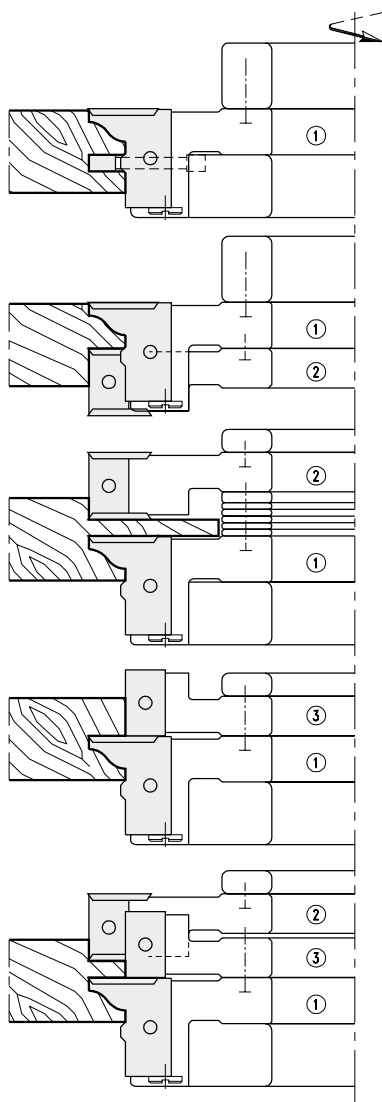



Für Weich- und Harthölzer bzw. Span- und Faserwerkstoffe, beschichtet oder Furniert.
For softwood and hardwood, chipboard and fibre material, plastic coated and veneered.

MAN

HW

| Nr. | D | B | d | Z | V | I | n min - n max | Art.Nr. |
|-----|-----|------|-------|---|---|---|---------------|---------------------|
| 1 | 125 | 4,0 | 40/50 | 2 | | 2 | 6100-10500 | 4879.125.004 |
| 2 | 155 | 8,0 | 40/50 | 2 | 4 | | 4300-8400 | 4879.155.008 |
| 3 | 139 | 9,8 | 40/50 | 2 | 2 | | 5600-9600 | 4879.139.010 |
| 4 | 153 | 15,0 | 40/50 | 2 | 2 | 2 | 5000-8600 | 4879.153.015 |
| 5 | 147 | 15,0 | 40/50 | 2 | 2 | | 5200-8900 | 4879.147.015 |

- WP-Profilmesserkopf mit Stahltragkörper zum Fräsen von Türfutter und Bekleidung. Für Weich- und Harthölzer bzw. Span- und Faserwerkstoffe, beschichtet oder Furniert.
- Ausführung für manuellen Vorschub.
- *TC-Profile cutterhead with steel tool body and reversible knives for door cases and door linings. For softwood and hardwood, chipboard and fibre material, plastic coated and veneered.*
- *Layout for manual feed.*

Wechselmesser/Ersatzteile
Reversible knives/Spare parts

| | Nr. | Dim. | Art.Nr. |
|---|-----|------------|-------------------|
| Wechselmesser - <i>Reversible knife</i> | 2 | 7,5x12x1,5 | 750.097 |
| | 3 | 9,6x12x1,5 | 750.098 |
| | 4/5 | 15x12x1,5 | 750.101 |
| Spannkeil - <i>Clamping wedge</i> | 2 | | 707.002.07 |
| | 3 | | 707.002.08 |
| | 4/5 | | 707.133.15 |
| Schraube - <i>Screw</i> | 2 | M5x12 | 705.523 |
| | 3 | M6x16 | 705.535 |
| | 4/5 | M8x12 | 705.541 |
| Vorschneider - <i>Spur</i> | | 14x12x2 | 750.111 |
| Schraube - <i>Screw</i> | | M5x7 | 705.425 |
| Nutmesser - <i>Groover</i> | 1 | 20x34x5 | 783.123 |
| | 1 | 20x26x5 | 783.124 |
| Abrundmesser - <i>Rounding blade</i> | | R3 | 780.251 |
| Fasemesser - <i>Chamfering blade</i> | | 45° | 780.260 |
| Schraube - <i>Screw</i> | | M5x13,5 | 705.318 |
| Sechskantschlüssel - <i>T Wrench</i> | | SW2,5(M5) | 706.102 |
| | | SW3(M6) | 706.103 |
| | | SW4(M8) | 706.104 |

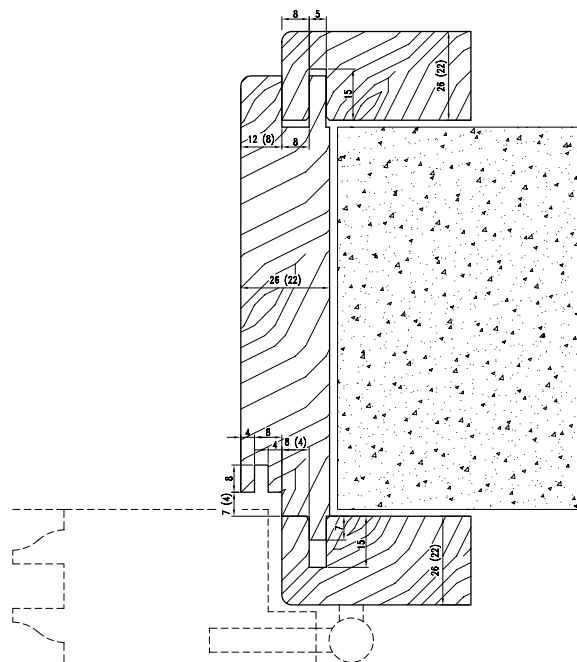
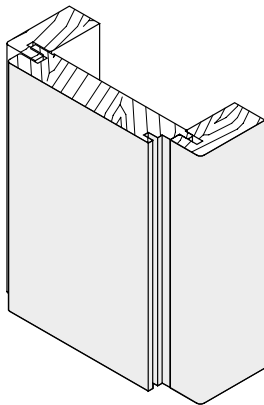
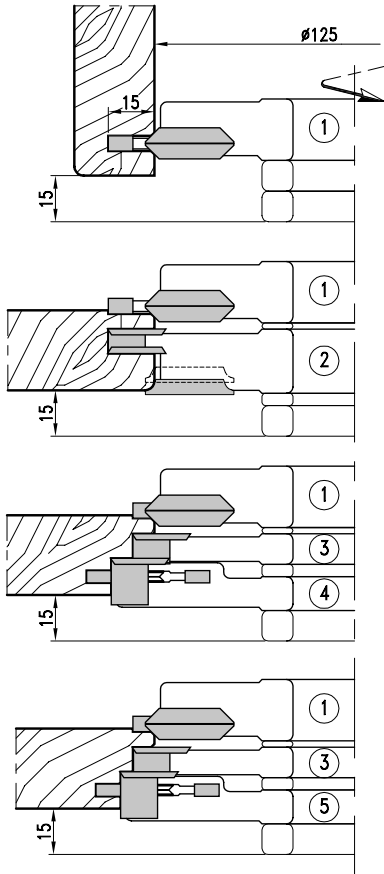



Für Weich- und Harthölzer bzw. Span- und Faserwerkstoffe, beschichtet oder Furniert.
For softwood and hardwood, chipboard and fibre material, plastic coated and veneered.

MEC**HW**

| Nr. | D | B | d | Z | V | I | n min - n max | Art.Nr. |
|-----|-----|----|-------|---|---|---|---------------|---------------------|
| 1 | 166 | 20 | 40/50 | 4 | | 2 | 7800 | 4884.166.020 |
| 2 | 102 | 25 | 40 | 4 | | | 14200 | 4884.102.025 |
| | 112 | 25 | 40/50 | 4 | | | 12000 | 4884.112.025 |
| 3 | 137 | 40 | 40/50 | 4 | | | 9500 | 4884.137.040 |
| 4 | 149 | 6 | 40/50 | 4 | 4 | | 8900 | 4884.149.006 |

- WP-Profilmesserkopf mit Stahltragkörper zum Fräsen von Tüfutter und Bekleidung.
- Ausführung für mechanischen Vorschub.
- *TC-Profile cutterhead with steel tool body and reversible knives for door cases and door linings.*
- *Layout for mechanical feed.*

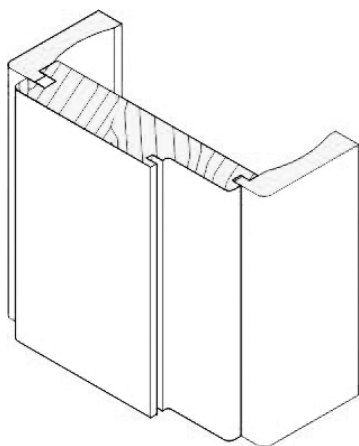
Wechselmesser/Ersatzteile
Reversible knives/Spare parts

| | Nr. | Dim. | Art.Nr. |
|----------------------------------|-----|------------|-------------------|
| Wechselmesser - Reversible knife | 1 | 20x12x1,5 | 785.110 |
| | 2 | 25x17x2 | 785.111 |
| | 3 | 40x20x2 | 785.112 |
| | 4 | 7,6x12x1,5 | 750.097 |
| Spannkeil - Clamping wedge | 1 | | 707.130.20 |
| | 2 | | 707.012.23 |
| | 3 | | 707.002.38 |
| | 4 | | 707.002.07 |
| Schraube - Screw (DIN 963) | 1/3 | M8x16 | 705.542 |
| | 2 | M6x16 | 705.535 |
| | 4 | M5x12 | 705.523 |
| Vorschneider - Spur | | 14x14x2 | 750.111 |
| Schraube - Screw (DIN 963) | | M5x8 | 705.422 |
| Nutmesser - Groover | | 25,55x13x4 | 783.101 |
| Schraube - Screw | | M5x13,5 | 705.318 |
| Sechskantschlüssel - T Wrench | | SW4 (M8) | 706.104 |
| | | SW3 (M6) | 706.103 |
| | | SW2,5 (M5) | 706.102 |

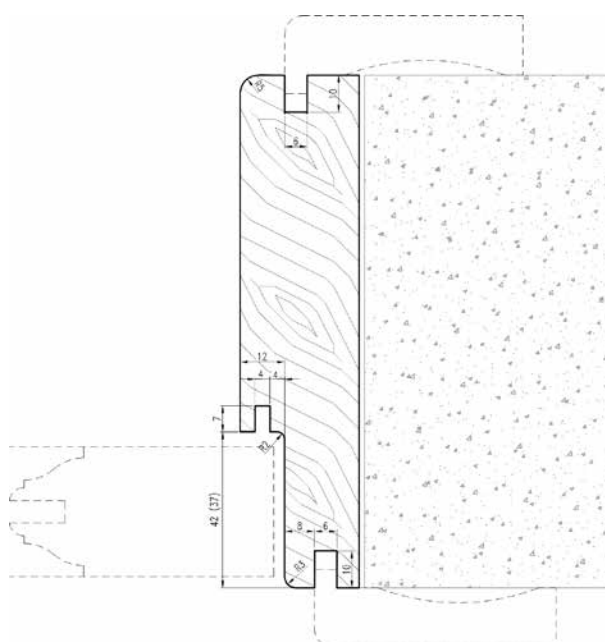
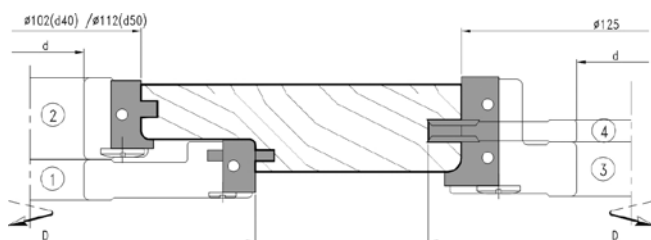



WP-Profilmesserkopf für Weich- und Harthölzer.
 TC-Profile cutterhead for softwood and hardwood

MEC

HW

| Nr. | D | B | d | Z | V | S | n max | Art.Nr. |
|---------|-----|-----|----|---|---|---|-------|----------------|
| 1 | 147 | 20 | 50 | 2 | | | 8900 | ● 4884.147.020 |
| 2 | 125 | 100 | 50 | 2 | | | 8900 | 4884.125.100 |
| 3 | 147 | 50 | 50 | 2 | 2 | 2 | 8900 | 4884.147.050 |
| 4 | 50 | 190 | 40 | | | | | 704.901 |
| 1+2+3+4 | | | | | | | | 4884.000.000 |

- ohne Wechselmesser
- supplied without knives

- WP-Profilmesserkopf mit Stahltragkörper zum Fräsen von Tüfuttern.
- Ausführung für mechanischen Vorschub.
- TC-Profile cutterhead with steel tool body and reversible knives for door cases.
- Layout for mechanical feed.

Wechselmesser/Ersatzteile
 Reversible knives/Spare parts

| | Nr. | Dim. | Art.Nr. |
|----------------------------------|-----|------------|------------|
| Wechselmesser - Reversible knife | 1 | 20x25x2 | 785.621 |
| | | 20x25x2 | 785.622 |
| | | 20x25x2 | 785.623 |
| Spannkeil - Clamping wedge | 2 | 100x13x2,2 | 750.109 |
| | 3 | 50x12x1,5 | 750.106 |
| | | | |
| Gewindestift - Screw (DIN915) | 1 | M8x16 | 707.084 |
| | 2 | | 707.002.98 |
| | 3 | | 707.130.48 |
| Vorschneider - Spur | | 14x14x2 | 705.542 |
| Spannschraube - Screw (DIN963) | | M5x8 | 750.111 |
| Abrundmesser - Rounding blade | | R1,5 | 705.422 |
| Schraube - Screw | | M5x13,5 | 780.205 |
| Sechskantschlüssel - T Wrench | | SW3(M5) | 705.318 |
| | | SW4(M8) | 706.103 |
| | | | 706.104 |

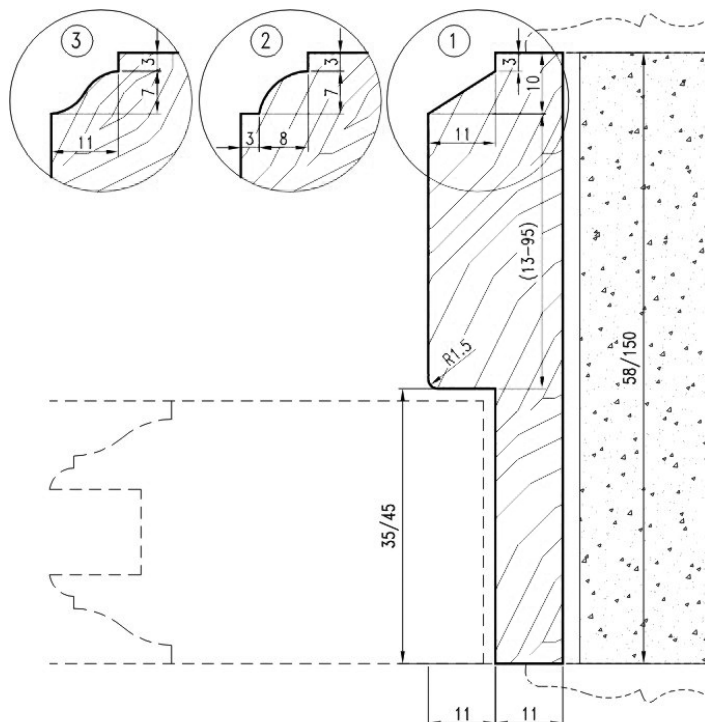
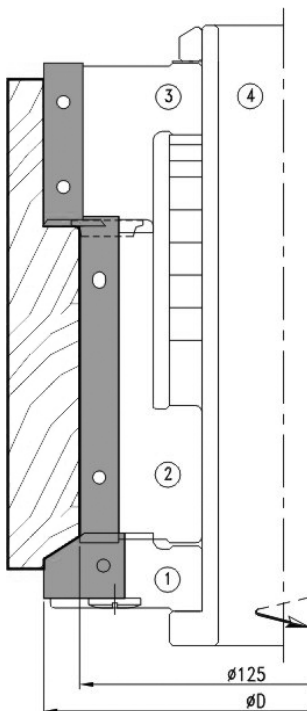

WP-Profilmesserkopf für Weich- und Harthölzer.
TC-Profile cutterhead for softwood and hardwood

MEC

HW

| Nr. | D | B | d | Z | V | n min - n max | Art.Nr. |
|-----|-----|----|----|---|---|---------------|-----------------------|
| 1 | 302 | 20 | 50 | 3 | | 2600-4400 | ● 5239.302.020 |
| 2 | | 10 | 50 | 3 | 6 | 2600-4400 | 5239.302.010 |
| 3 | 280 | 10 | 50 | 3 | 6 | 2800-4700 | 5199.280.010 |
| 4 | | 50 | 50 | 3 | 3 | 2800-4700 | 5239.280.050 |
| 5 | 302 | 10 | 50 | 3 | 6 | 2800-4400 | 5199.302.010 |

- ohne Wechselmesser
supplied without knives

- WP-Profilmesserkopf mit Stahltragkörper zum Fräsen von Türfuttern.
- Ausführung für mechanischen Vorschub.
- *TC-Profile cutterhead with steel tool body and reversible knives for door cases.*
- *Layout for mechanical feed.*

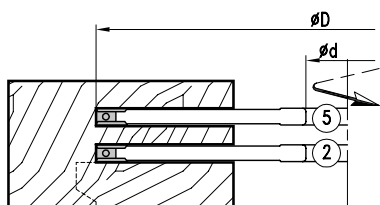
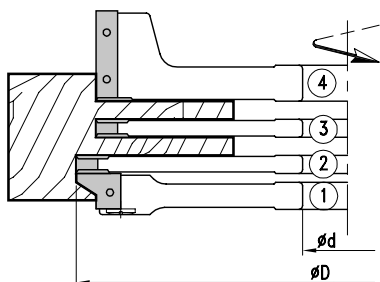
Wechselmesser/Ersatzteile
Reversible knives/Spare parts

| | Nr. | P | Dim. | Art.Nr. |
|---|-------|----|------------|-------------------|
| Wechselmesser - <i>Reversible knife</i> | 1 | P1 | 20x25x2 | 785.625 |
| | | P2 | 20x25x2 | 785.626 |
| | | P3 | 20x25x2 | 785.627 |
| Spannkeil - <i>Clamping wedge</i> | 2/3/5 | | 9,6x12x1,5 | 750.098 |
| | 4 | | 50x12x1,5 | 750.106 |
| | 1 | | | 707.085 |
| Gewindestift - <i>Screw</i> | 2/3/5 | | M8x16 | 705.542 |
| | | | M6x16 | 705.535 |
| | 4 | | | 707.130.50 |
| Vorschneider - <i>Spur</i> | | | 14x14x2 | 705.111 |
| Spannschraube - <i>Screw</i> | | | M5x8 | 705.422 |
| Sechskantschlüssel - <i>T Wrench</i> | | | SW3(M6) | 706.103 |
| | | | SW4(M8) | 706.104 |

Profile, siehe Art. 4884
Profiles, see Art. 4884

- Serienartikel, kurzfristige Fertigung bei Bestellung
- *Standard article, short-time production after order*

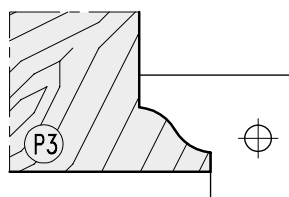
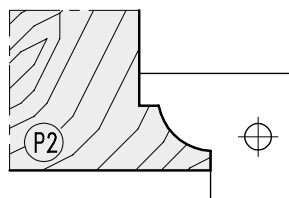
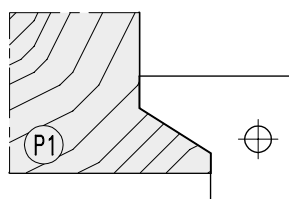
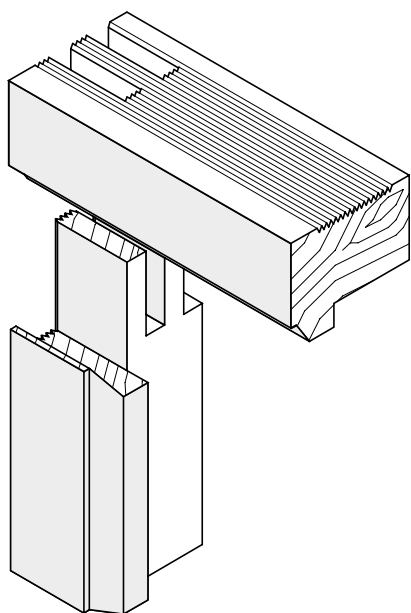



Profil- und Konterprofilgarnitur
Profile- and counterprofile cutterset

MAN

HW

| Nr. | D | B | d | Z | V | n min - n max | Art.Nr. |
|-----|-----|----|----|---|---|---------------|----------------|
| 1 | 140 | 20 | 50 | 3 | | 5500-9500 | ● 4899.140.020 |
| 2 | | 8 | 50 | 4 | 4 | 5500-9500 | ● 5149.140.008 |
| 3 | | 20 | 50 | 3 | | 5500-9500 | ● 4899.140.120 |
| 4 | 302 | 20 | 50 | 3 | | 2600-4400 | ● 4899.302.020 |
| 5 | | 20 | 50 | 3 | | 2600-4400 | ● 4899.302.120 |

- ohne Wechselsmesser
- *supplied without knives*

- WP-Profilmesserkopf mit Stahltragkörper zum Fräsen von Profil und Konterprofil an Massivholz-Rahmentüren.
- Zehn verschiedene Profilfräsergarnituren.
- Ausführung für manuellen Vorschub.
- *TC-Profile cutterhead with steel tool body and reversible knives for profiles and counter profiles in solid wood framed doors.*
- *Ten different profilecuttersets.*
- *Layout for manual feed.*

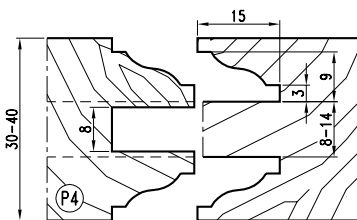
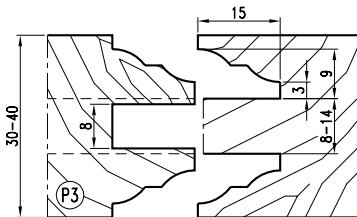
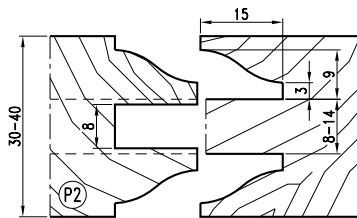
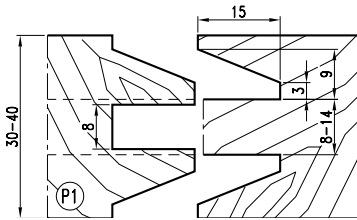

Wechselsmesser/Ersatzteile
Reversible knives/Spare parts

| | P | Dim. | Nr. | Art.Nr. |
|--|--------------|--------------|---------|------------|
| Wechselsmesser - <i>Reversible knife</i> | P1 | 20x30x2 (P1) | 1 | 785.601 |
| | P1 | 20x30x2 (P1) | 3 | 785.602 |
| | P1 | 20x30x2 (P1) | 4 | 785.603 |
| | P1 | 20x30x2 (P1) | 5 | 785.604 |
| | P2 | 20x30x2 (P2) | 1 | 785.605 |
| | P2 | 20x30x2 (P2) | 3 | 785.606 |
| | P2 | 20x30x2 (P2) | 4 | 785.607 |
| | P2 | 20x30x2 (P2) | 5 | 785.608 |
| | P3 | 20x30x2 (P3) | 1 | 785.609 |
| | P3 | 20x30x2 (P3) | 3 | 785.610 |
| | P3 | 20x30x2 (P3) | 4 | 785.611 |
| | P3 | 20x30x2 (P3) | 5 | 785.612 |
| | P4 | 20x30x2 (P4) | 1 | 785.613 |
| | P4 | 20x30x2 (P4) | 3 | 785.614 |
| | P4 | 20x30x2 (P4) | 4 | 785.615 |
| P4 | 20x30x2 (P4) | 5 | 785.616 | |
| Spannkeil - <i>Clamping wedge</i> | | 7,5x12x1,5 | 2 | 750.097 |
| | | | 1 | 707.080 |
| | | | 2 | 707.002.07 |
| | | | 3 | 707.081 |
| | | | 4 | 707.082 |
| Gewindestift - <i>Screw</i> | | M5x16 | 5 | 707.083 |
| | | M8x16 | 1 | 705.582 |
| | | 14x14x2 | 1 | 705.542 |
| | | M5x6 | 1 | 750.111 |
| | | M5x6 | 1 | 705.424 |
| Vorschneider - <i>Spur</i> | | 14x14x2 | 1 | 750.111 |
| | | M5x6 | 1 | 705.424 |
| Spannschraube - <i>Screw</i> | | M5x6 | 1 | 705.424 |
| | | M5x6 | 1 | 705.424 |
| Sechskantschlüssel - <i>T Wrench</i> | | SW2,5 (M5) | 1 | 706.102 |
| | | SW4 (M8) | 1 | 706.104 |

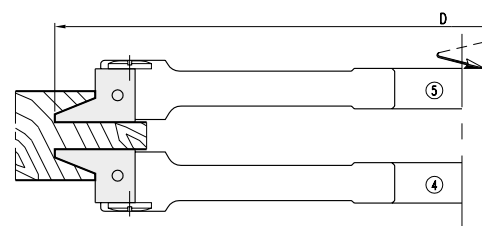
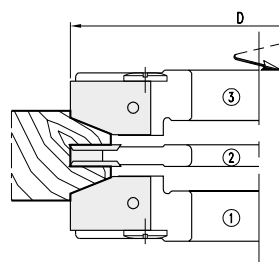

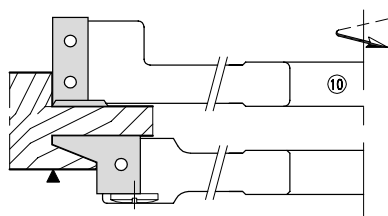
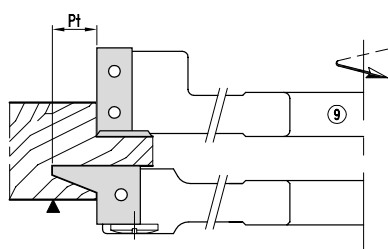
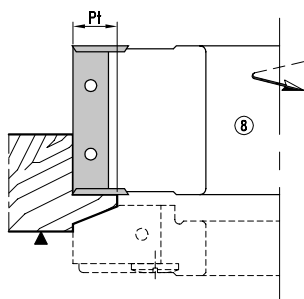
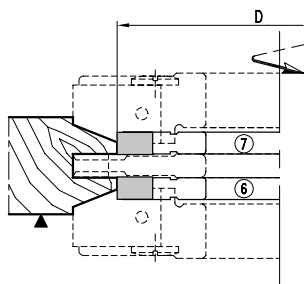
Profil- und Konterprofilgarnitur für Türen
Profile- and counterprofile cutterset for doors

HW

| Nr. | D | B | d | Z | V | Pt | n min - n max | Art.Nr. |
|-----|-----|------|----|---|---|----|---------------|---------------------|
| 6 | 110 | 7,6 | 50 | 3 | | | 6900-12000 | 4899.110.008 |
| 7 | | 7,6 | 50 | 3 | | | 6900-12000 | 4899.110.108 |
| 8 | 132 | 30,0 | 50 | 3 | 3 | 11 | 5800-10000 | 4899.132.030 |
| 8 | | 50,0 | 50 | 3 | 3 | 11 | 5800-10000 | 4899.132.050 |
| 8 | 140 | 50,0 | 50 | 4 | 4 | 15 | 5500-9500 | 5769.140.050 |
| 9 | 272 | 30,0 | 50 | 3 | 3 | 15 | 2800-4800 | 5249.272.230 |
| 9 | 280 | 30,0 | 50 | 3 | 3 | 11 | 2800-4700 | 5249.280.230 |
| 10 | 302 | 30,0 | 50 | 3 | 3 | | 2600-4400 | 5249.302.230 |

Wechselmesser/Ersatzteile
Reversible knives/Spare parts

| | Nr. | Dim. | Art.Nr. |
|---|------|------------|-------------------|
| Wechselmesser - <i>Reversible knife</i> | 6/7 | 7,5x12x1,5 | 750.097 |
| | 9/10 | 30x12x1,5 | 750.104 |
| | 8 | 50x12x1,5 | 750.106 |
| Spannkeil - <i>Clamping wedge</i> | 6/7 | | 707.002.07 |
| | 9/10 | | 707.130.30 |
| | 8 | | 707.130.50 |
| Gewindestift - <i>Screw</i> | 6/7 | M6x12 | 705.533 |
| | | M8x16 | 705.542 |
| Vorschneider - <i>Spur</i> | | 14x14x2 | 705.111 |
| Spannschraube - <i>Screw</i> | | M5x8 | 705.422 |
| Sechskantschlüssel - <i>T Wrench</i> | | SW3(M6) | 706.103 |
| | | SW4(M8) | 706.104 |



MAN

HW



Profil- und Konterprofilgarnitur für Türen
Profile- and counterprofile cutterset for doors

| Nr. | D | B | d | Z | V | n min - n max | Art.Nr. |
|--------------------------------------|-----|------|-------|---|---|---------------|----------------|
| 1 | 160 | 25 | 30/50 | 2 | | 4800-8300 | ● 4894.160.025 |
| 2 | | 8-15 | 30/50 | 4 | 4 | 4800-8300 | ● 4894.160.008 |
| 3 | | 25 | 30/50 | 2 | | 4800-8300 | ● 4894.160.125 |
| Garnitur (1+2+3) • Cutterset (1+2+3) | | | | | | | 4894.000.000 |

- WP-Profilmesserkopf mit Stahltragkörper zum Fräsen von Profil und Konterprofil an Massivholz-Rahmentüren. Garnitur aus drei verschiedenen Profilfräsern.
- Ausführung für manuellen Vorschub.
- TC-Profile cutterhead with steel tool body and reversible knives for profiles and counter profiles in solid wood framed doors. Set with three different profile cutters.
- Layout for manual feed.

Wechselmesser/Ersatzteile
Reversible knives/Spare parts

| | P | Nr. | Dim. | Art.Nr. |
|----------------------------------|----|-----|------------|------------|
| Wechselmesser - Reversible knife | P1 | 1 | 29,5x25x2 | 785.502 |
| | P1 | 3 | 29,5x25x2 | 785.501 |
| | P2 | 1 | 29,5x25x2 | 785.504 |
| | P2 | 3 | 29,5x25x2 | 785.503 |
| | P3 | 1 | 29,5x25x2 | 785.506 |
| | P3 | 3 | 29,5x25x2 | 785.505 |
| Spannkeil - Clamping wedge | | 2 | 7,5x12x1,5 | 750.097 |
| | | 1 | | 750.531 |
| | | 2 | | 707.002.06 |
| Gewindestift - Screw | | 3 | | 707.530 |
| | | 2 | M5x12 | 705.523 |
| | | 1/3 | M6x16 | 705.535 |
| Vorschneider - Spur | | | 14x14x2 | 750.111 |
| Spannschraube - Screw | | | M5x8 | 705.422 |
| Sechskantschlüssel - T Wrench | | | SW2,5 | 706.102 |
| | | | SW3 | 706.103 |

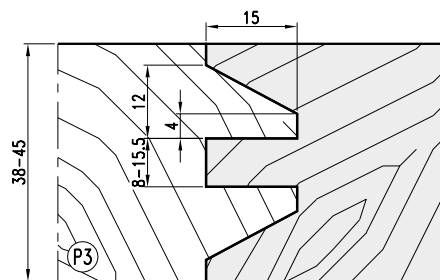
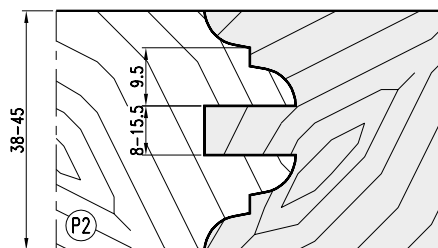
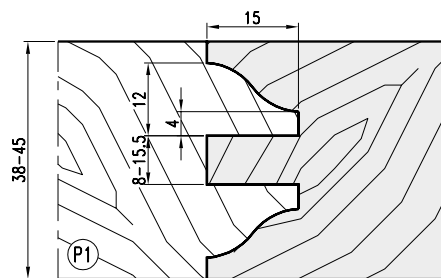
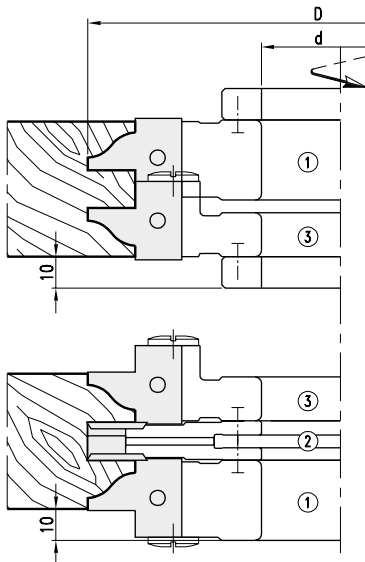

Türprofil- und Konterprofilgarnitur
Profile- and counterprofile cutterset for doors

MAN

HW

| Nr. | D | B | d | Z | n min - n max | Art.Nr. |
|-----|-----|----|-------|---|---------------|---------------------|
| 1 | 138 | 25 | 30/50 | 3 | 5600-9600 | 4839.138.025 |
| 2 | 153 | 20 | 30/50 | 3 | 5000-8600 | 4839.153.020 |
| 3 | 151 | 20 | 30/50 | 3 | 5000-8600 | 4839.151.020 |

- WP-Profilmesserkopf mit Stahltragkörper zum Fräsen von Sprossen und Leisten an Massivholz-Rahmentüren. Garnitur aus drei verschiedenen Profilfräsern.
- Ausführung für manuellen Vorschub.
- *TC-Profile cutterhead with steel tool body and reversible knives for beads and mouldings in solid wood framed doors. Set with three different profilecutters.*
- *Layout for manual feed.*

Wechselmesser/Ersatzteile
Reversible knives/Spare parts

| | Nr. | Dim. | Art.Nr. |
|---|-----|-----------|-------------------|
| Wechselmesser - <i>Reversible knife</i> | 1 | 25x20x2 | 785.774 |
| | 2 | 20x20x2 | 785.775 |
| | 3 | 20x12x1,5 | 750.102 |
| Spannkeil - <i>Clamping wedge</i> | 1 | | 707.002.23 |
| | 2 | | 707.576.01 |
| | 3 | | 707.133.20 |
| Gewindestift - <i>Screw</i> | | M8x16 | 705.542 |
| Vorschneider - <i>Spur</i> | | 14x14x2 | 750.111 |
| Spannschraube - <i>Screw</i> | | M5x8 | 705.422 |
| Sechskantschlüssel - <i>T Wrench</i> | | SW4 | 706.104 |

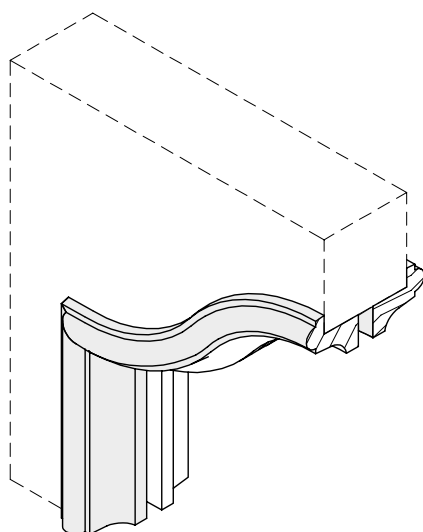
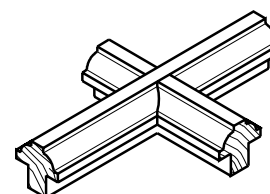
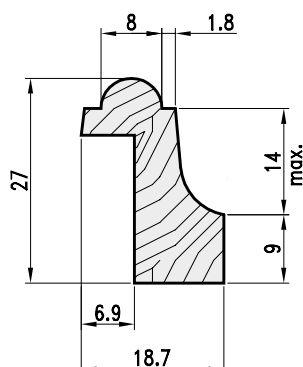
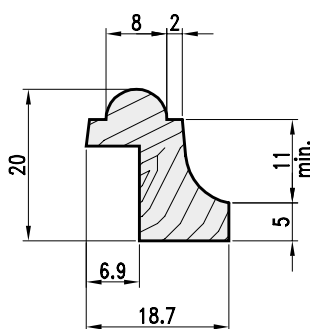
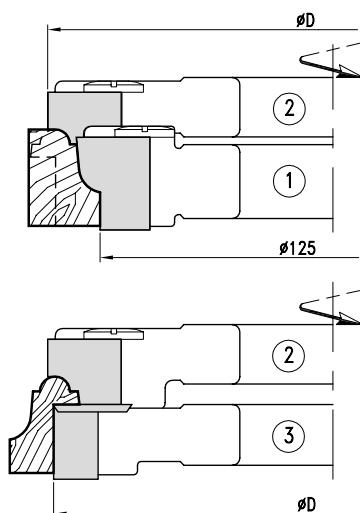

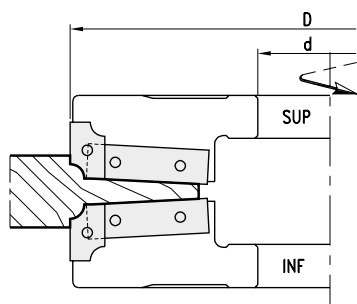
Abplattfräser
Panel raising cutter
MAN
HW

| D | B | d | Z | n min - n max | SUP | INF |
|-----|----|-------|-----|---------------|----------------|--------------|
| 180 | 30 | 30/50 | 2+2 | 4300-7400 | ● 5279.180.030 | 5279.180.130 |

- Abplattfräser wird mit P1 geliefert, auf Anfrage mit P2, P3 oder Profilen nach Wunsch.
- Cutterhead equipped with tips for basic profile P1
- WP-Pofilmesserkopf mit Stahltragkörper zum Abplatten von Rahmenfüllungen.
- Profilmesserkopf für drei verschiedene Abplattprofile zum einseitigen oder beidseitigen Abplatten.
- Ausführung für manuellen Vorschub.
- TC-Panel raising cutter with steel tool body and reversible knives for solid wood panels.
- Cutterhead for three different panel raising profiles by knife change.
- Layout for manual feed.

Wechselmesser/Ersatzteile
Reversible knives/Spare parts

| | Nr. | Dim. | Art.Nr. |
|---|---------|-----------|---------|
| Wechselmesser - <i>Reversible knife</i> | 1 (SUP) | 20x12x1,5 | 781.111 |
| | 2 | 20x12x1,5 | 781.112 |
| | 3 | 20x12x1,5 | 781.113 |
| | 1 (INF) | 20x12x1,5 | 781.114 |
| | 2 | 20x12x1,5 | 781.115 |
| | 3 | 20x12x1,5 | 781.116 |
| Spannkeil - <i>Clamping wedge</i> | SUP | | 781.273 |
| | INF | | 707.275 |
| Wendemesser - <i>Reversible knife</i> | | 50x12x1,5 | 750.106 |
| Spannkeil - <i>Clamping wedge</i> | SUP | | 707.274 |
| | INF | | 707.276 |
| Gewindestift - <i>Screw</i> | | M8x16 | 705.542 |
| Sechskantschlüssel - <i>T Wrench</i> | SW4 | | 706.104 |
| Einstellehre - <i>Adjusting gauge</i> | | 1,0 | 709.504 |

- Standardprofil P1 und weitere Profilmöglichkeiten
- Basic profile P1 and further profile variations

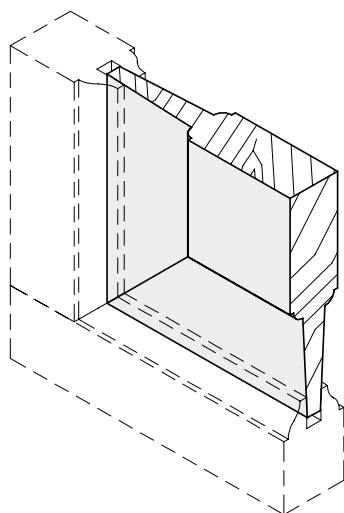

- Weitere Profilmöglichkeiten
- Further profile variations

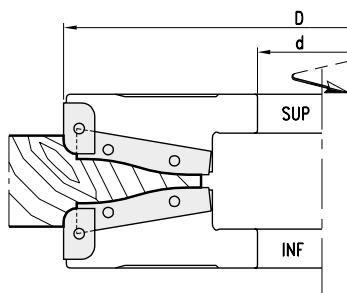
Abplattfräser
Panel raising cutter
MAN**HW**

| D | B | d | Z | n min - n max | SUP | INF |
|-----|----|-------|-----|---------------|----------------|--------------|
| 200 | 30 | 30/50 | 2+2 | 3900-6600 | ● 5279.200.030 | 5279.200.130 |

- Abplattfräser wird mit P1 geliefert, auf Anfrage mit P2, P3 oder Profilen nach Wunsch.
- *Cutterhead equipped with tips for basic profile P1*
- WP-Profilmesserkopf mit Stahltragkörper zum Abplatten von Rahmenfüllungen.
- Profilmesserkopf für drei verschiedene Abplattprofile zum einseitigen oder beidseitigen Abplatten.
- Ausführungen für manuellen Vorschub.
- *TC-Panel raising cutter with steel tool body and reversible knives for solid wood panels.*
- *Cutterhead for three different panel raising profiles by knife change.*
- *Layout for manual feed.*

Wechselmesser/Ersatzteile
Reversible knives/Spare parts

| | Nr. | Dim. | Art.Nr. |
|---|---------|-----------|----------------|
| Wechselmesser - <i>Reversible knife</i> | 1 (SUP) | 20x12x1,5 | 781.111 |
| | 2 | 20x12x1,5 | 781.112 |
| | 3 | 20x12x1,5 | 781.113 |
| 1 (INF) | 1 (INF) | 20x12x1,5 | 781.114 |
| | 2 | 20x12x1,5 | 781.115 |
| | 3 | 20x12x1,5 | 781.116 |
| Spannkeil - <i>Clamping wedge</i> | SUP | | 781.273 |
| | INF | | 707.275 |
| Wendemesser - <i>Reversible knife</i> | SUP | 60x12x1,5 | 781.120 |
| | INF | 60x12x1,5 | 781.121 |
| Spannkeil - <i>Clamping wedge</i> | SUP | | 707.272 |
| | INF | | 707.277 |
| Gewindestift - <i>Screw</i> | | M8x16 | 705.542 |
| Sechskantschlüssel - <i>T Wrench</i> | | SW4 | 706.104 |
| Einstellehre - <i>Adjusting gauge</i> | | 1,0 | 709.504 |

- Standardprofil P1 und weitere Profilmöglichkeiten
- *Basic profile P1 and further profile variations*

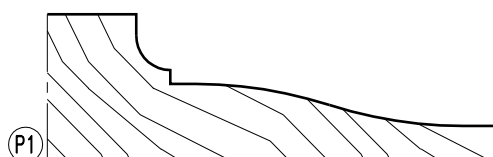
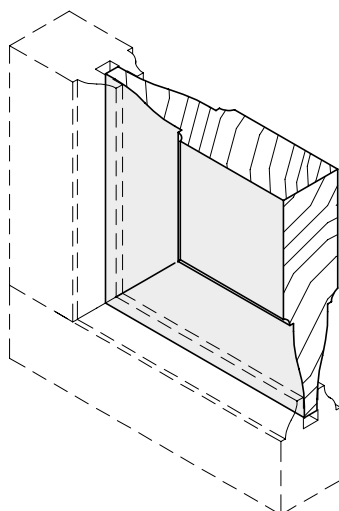

- Weitere Profilmöglichkeiten
- *Further profile variations*



Abplattfräser
Panel raising cutter

MAN

HW

| D | B | d | Z | n min - n max | SUP | INF |
|-----|----|-------|-----|---------------|----------------|--------------|
| 200 | 30 | 30/50 | 2+2 | 3900-6600 | ● 5279.200.030 | 5279.200.130 |

- Abplattfräser wird mit P1 geliefert, auf Anfrage mit P2, P3 oder Profilen nach Wunsch.
- *Cutterhead equipped with tips for basic profile P1*
- WP-Pofilmesserkopf mit Stahltragkörper zum Abplatten von Rahmenfüllungen.
- Profilmesserkopf für vier verschiedene Abplattprofile zum einseitigen oder beidseitigen Abplatten.
- Ausführungen für manuellen Vorschub.
- *TC-Panel raising cutter with steel tool body and reversible knives for solid wood panels.*
- *Cutterhead for four different panel raising profiles by knife change.*
- *Layout for manual feed.*

Wechselmesser/Ersatzteile
Reversible knives/Spare parts

| | Nr. | Dim. | Art.Nr. |
|---|---------|-----------|---------|
| Wechselmesser - <i>Reversible knife</i> | 1 (SUP) | 25x30x2 | 782.501 |
| | 2 | 25x30x2 | 782.502 |
| | 3 | 25x30x2 | 782.503 |
| | 4 | 25x30x2 | 782.504 |
| | 1 (INF) | 25x30x2 | 782.505 |
| | 2 | 25x30x2 | 782.506 |
| | 3 | 25x30x2 | 782.507 |
| | 4 | 25x30x2 | 782.508 |
| Spannkeil - <i>Clamping wedge</i> | SUP | | 707.561 |
| | INF | | 707.953 |
| Wendemeser - <i>Reversible knife</i> | | 50x12x1,5 | 750.106 |
| | | | |
| Spannkeil - <i>Clamping wedge</i> | SUP | | 707.144 |
| | INF | | 707.139 |
| Gewindestift - <i>Screw</i> | | M8x16 | 705.542 |
| | | M10x16 | 705.551 |
| Sechskantschlüssel - <i>T Wrench</i> | | SW4 | 706.104 |
| | | SW5 | 706.105 |

- Standardprofil P1 und weitere Profilmöglichkeiten
- *Basic profile P1 and further profile variations*

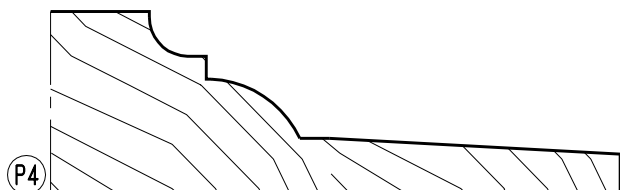
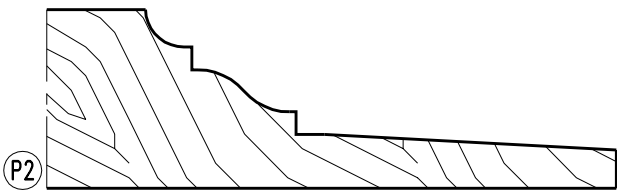
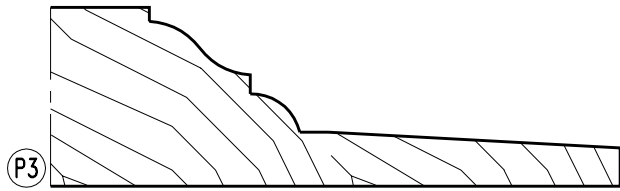
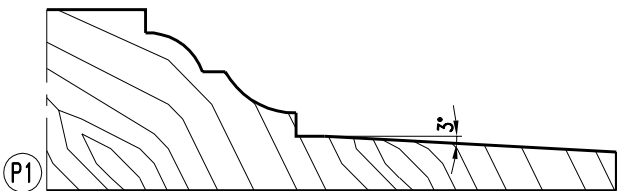
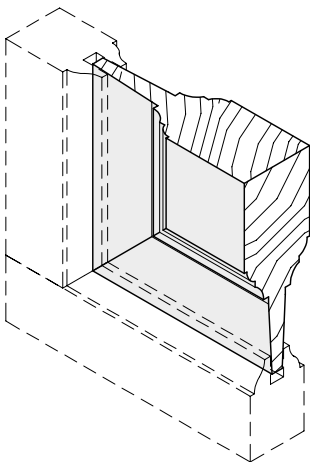
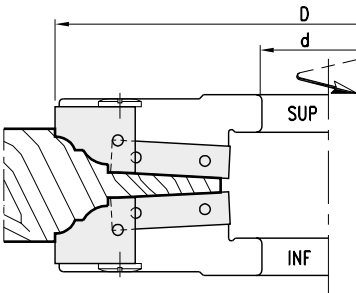

- Weitere Profilmöglichkeiten
- *Further profile variations*

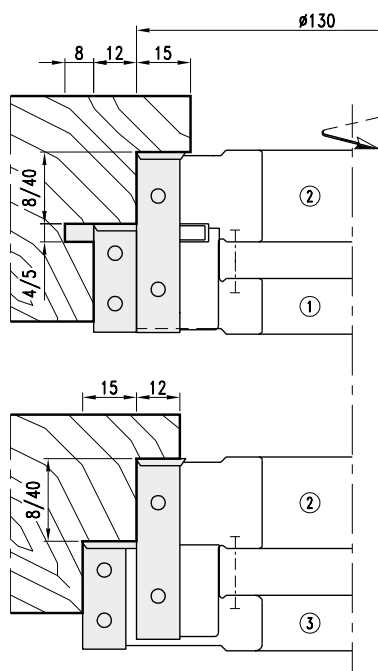

Türblatt- Doppelfalz Fräsgarnitur
Doorblade- double rebate cutterset

MAN

HW

| Nr. | D | B | d | Z | V | l | n min - n max | Art. Nr. |
|-----|-----|----|----|---|---|---|---------------|---------------------|
| 1 | 154 | 30 | 50 | 2 | 2 | 2 | 5000-8600 | 5299.154.030 |
| 2 | 130 | 50 | 50 | 2 | 2 | | 5800-10000 | 5299.130.050 |
| 3 | 160 | 30 | 50 | 2 | 2 | | 4800-8200 | 5299.160.030 |
| 4 | 140 | 30 | 50 | 2 | 2 | | 5500-9500 | 5299.140.030 |
| 5 | 124 | 30 | 50 | 2 | 2 | | 6400-11100 | 5299.124.030 |

- WP-Doppelfalz-Messerkopf mit Stahltragkörper zum Fräsen von Doppelfalzprofilen mit und ohne Rahmendichtung. Für Weich- und Harthölzer, Verbundwerkstoffe.
- Ausführung für manuellen Vorschub.
- TC-Double rebate cutterhead with steel tool body and reversible knives for double rebate profiles with and without frame seals. For softwood, hardwood and compound materials.
- Layout for manual feed.

Wechselmesser/Ersatzteile
Reversible knives/Spare parts

| | Nr. | Dim. | Art.Nr. |
|---|---------|-----------|-------------------|
| Wechselmesser - <i>Reversible knife</i> | | 30x12x1,5 | 750.104 |
| | | 50x12x1,5 | 750.106 |
| Spannkeil - <i>Clamping wedge</i> | 1/3/4/5 | | 707.002.28 |
| | 2 | | 707.002.48 |
| Gewindestift - <i>Screw</i> | | M8x16 | 705.542 |
| Vorschneider - <i>Spur</i> | 2 | 14x14x2 | 750.111 |
| Spannschraube - <i>Screw</i> | | M5x8 | 705.422 |
| Nutmesser - <i>Grooving knife</i> | | 17x35x4 | 783.120 |
| | | 17x35x5 | 783.121 |
| Schraube - <i>Screw</i> | | M5x13,5 | 705.318 |
| Sechskantschlüssel - <i>T Wrench</i> | | SW3(M5) | 706.103 |
| | | SW4(M8) | 706.104 |

- Standardprofil P1 und weitere Profilmöglichkeiten
- *Basic profile P1 and further profile variations*

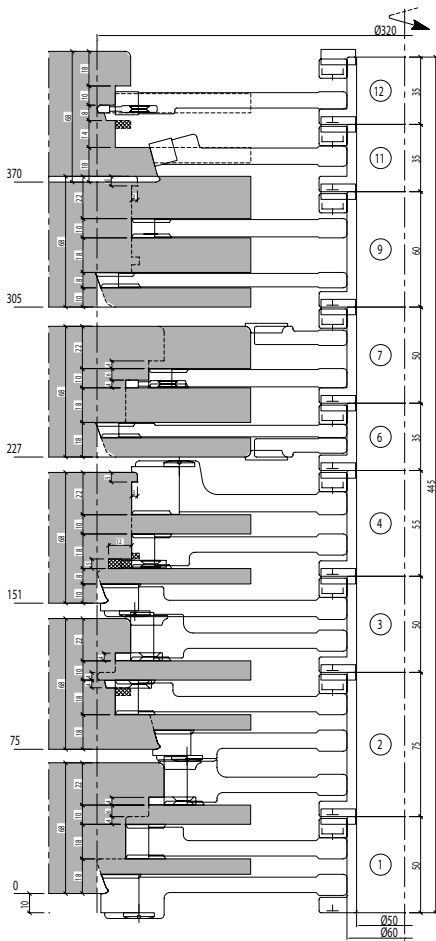

- Werkzeuge zur Fensterherstellung für alle Bearbeitungsmaschinen (manueller oder mechanischer Vorschub). Hergestellt konform zur Norm DIN EN-847-1.
 - Fenstergarnituren werden auf die erforderlichen Nullabstimmungsdurchmesser aufgebaut.
 - Alle Werkzeugsätze sind mit Schraubbüchsen verschraubt.
 - Werkzeugsätze sind durchmesser- und höhenabgestimmt.
-
- *Window tooling for all types of machinery (hand or mechanical feed). Designed according to the European standard EN 847-1.*
 - *Cutterhead sets mounted on sleeve with base diameter and height.*
 - *Technical characteristics according to the machine and working conditions.*

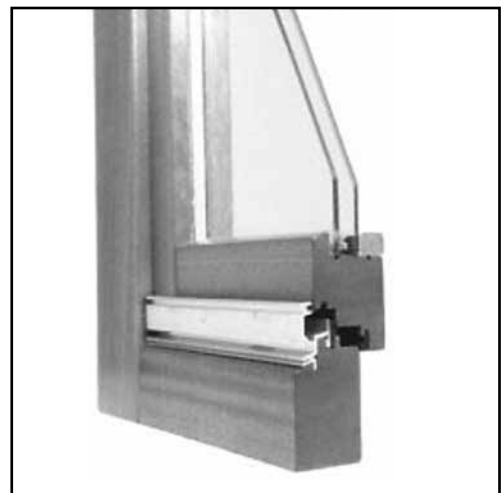
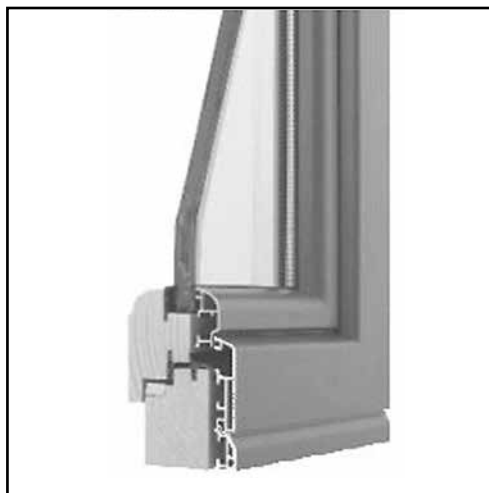

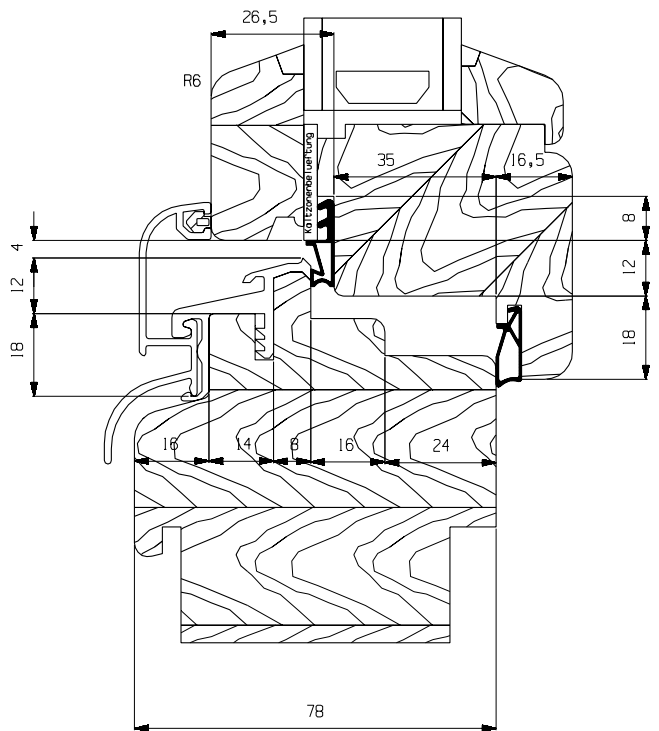
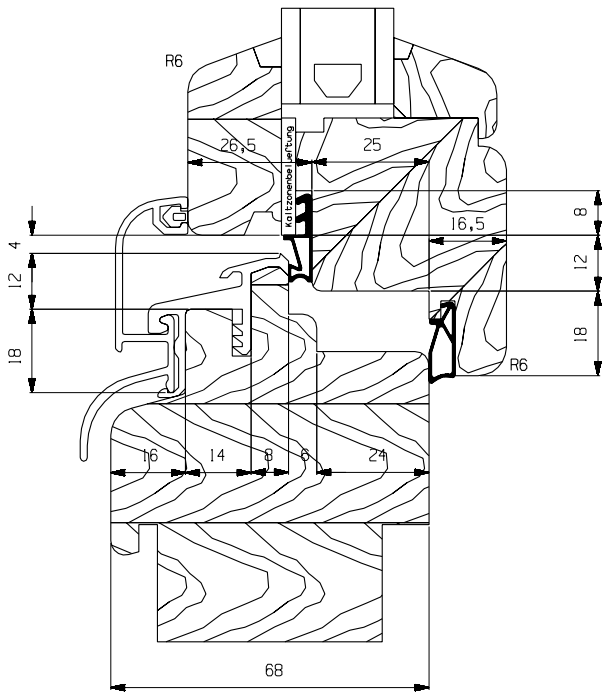
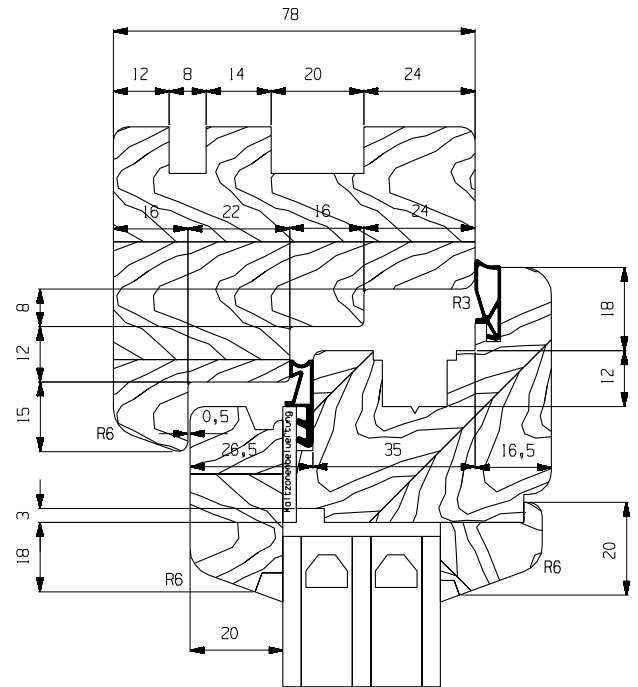
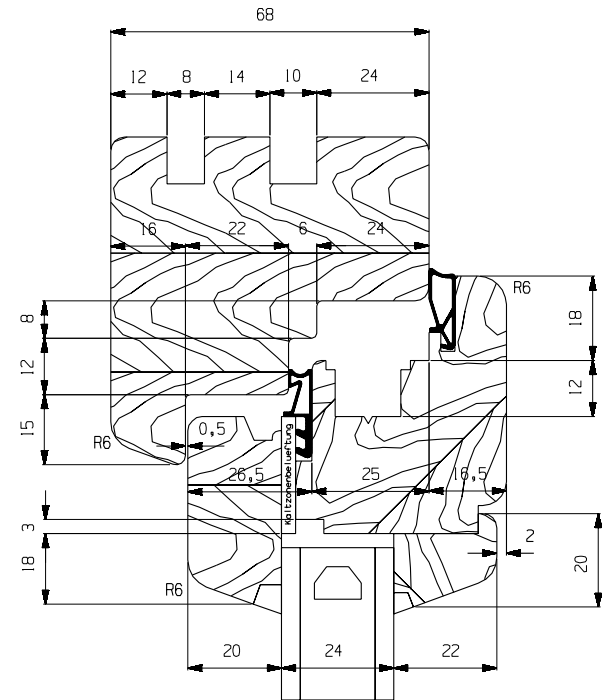

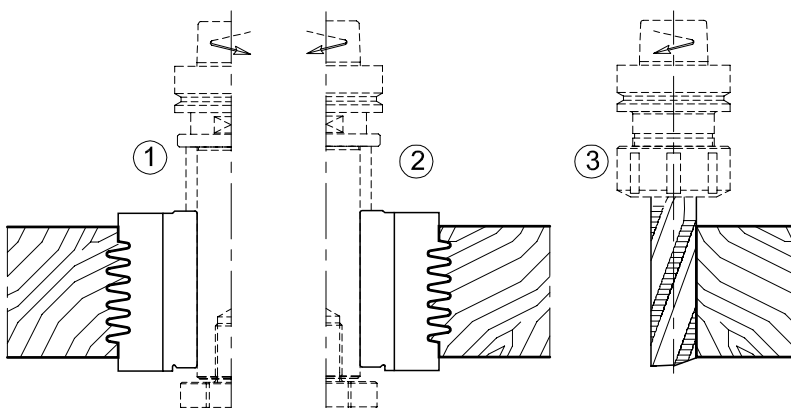
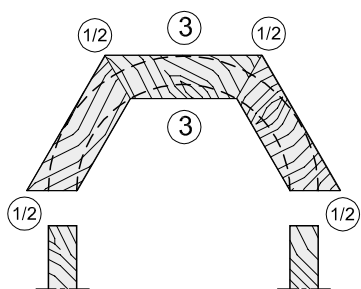

Option A

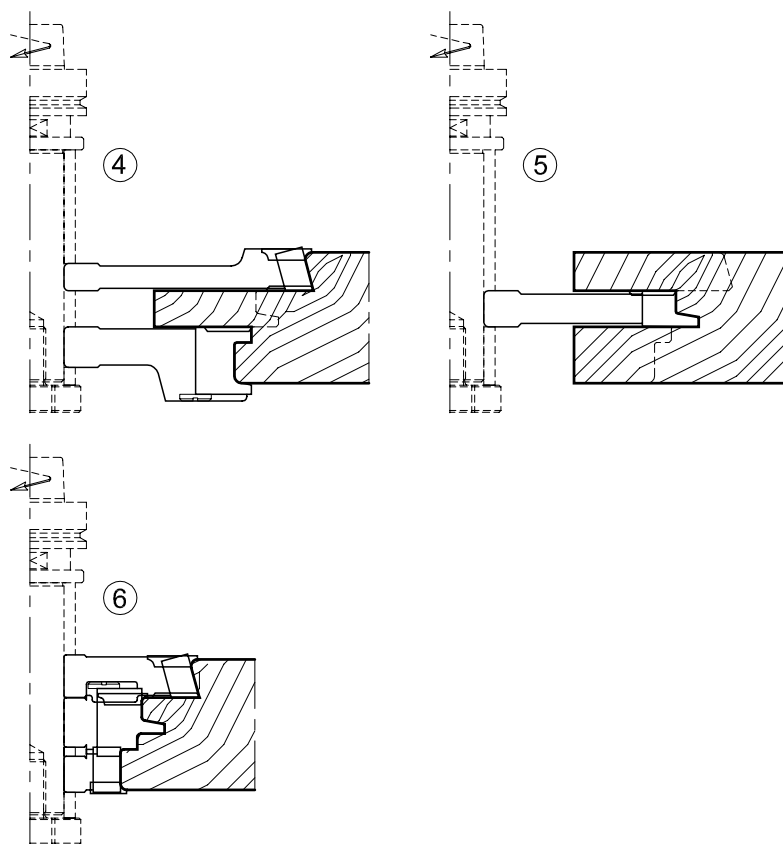
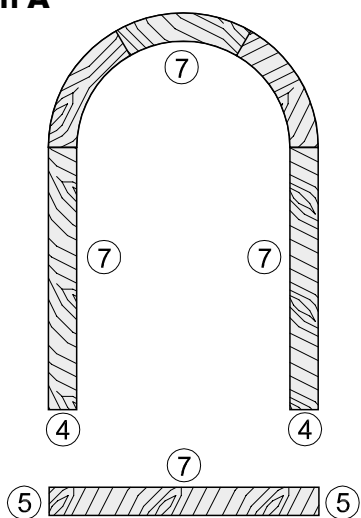

Option B

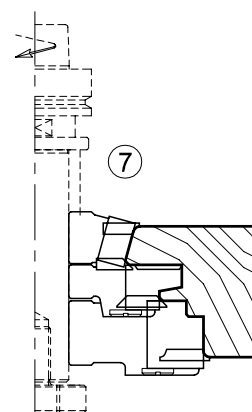
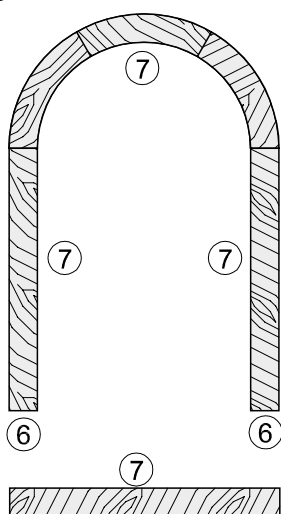

- 01 Sägen
- 02 Hobeln
- 03 Hobeln / Fräsen
- 04 Profillösen
- 05 Nut- und Federlösen
- 06 Ob-vertiefen
- 07 Bohren
- 08 PKD-Werkzeuge
- 09 Spannen
- 10 Ersatzteile
- 11 Informationen

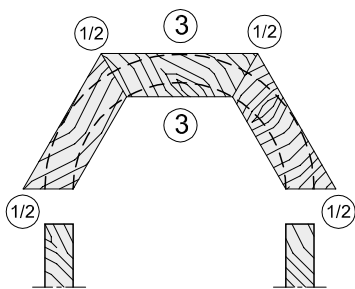

Option A

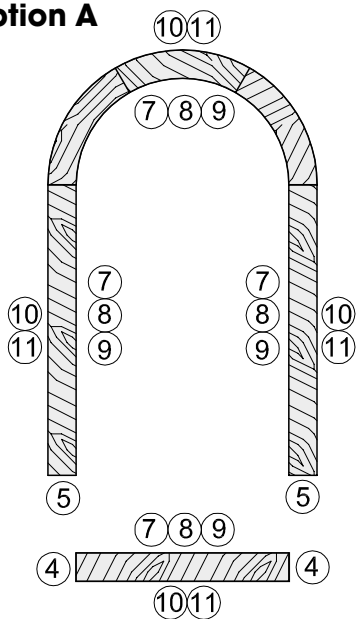
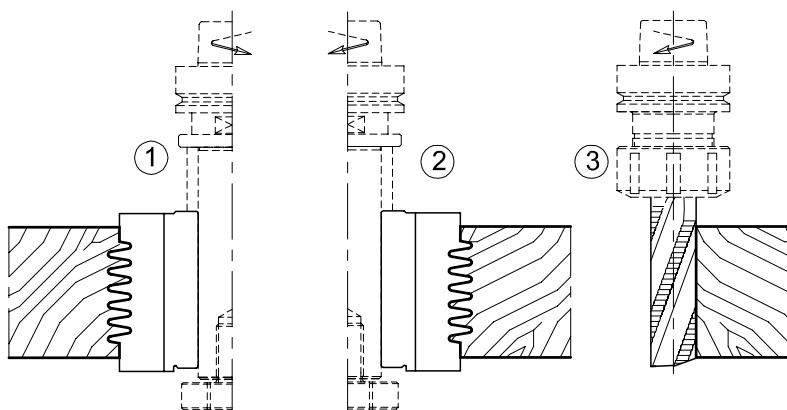

Option B

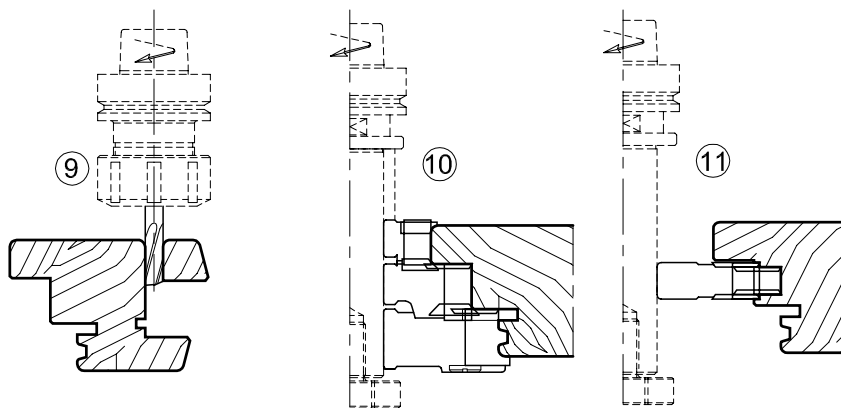
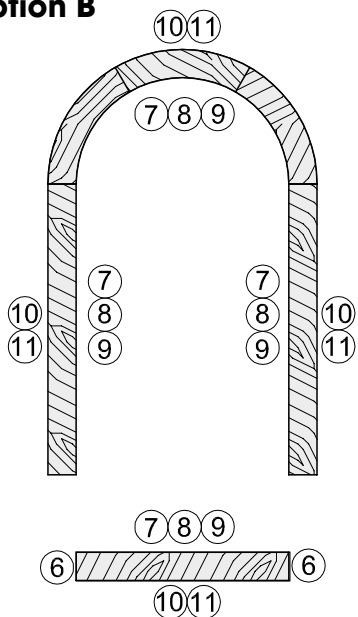
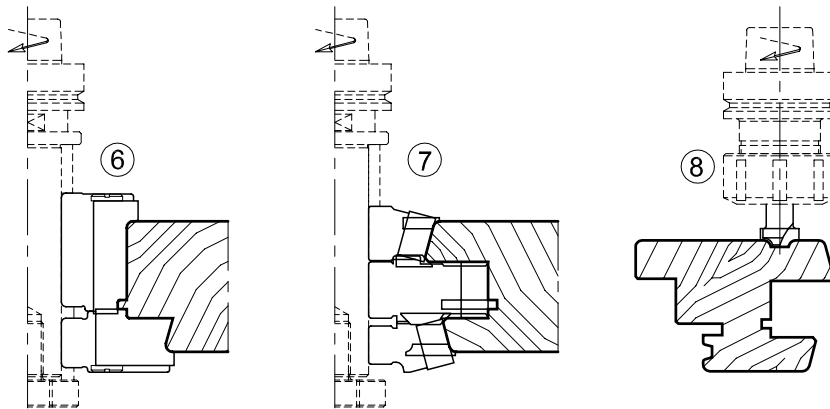
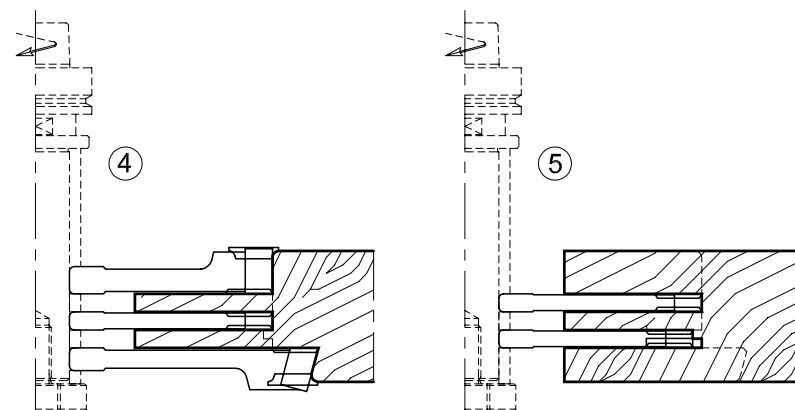

Konterprofilfräser für Aluminiumprofile
Counterprofile cutter for aluminium profiles

MEC

HW



| Nr. | D | B | d | Z | Art. Nr. |
|----------------------|-----|-----|----|---|---------------------|
| Profil 1 • Profile 1 | | | | | |
| 1 | 100 | 7,5 | 32 | 8 | 8974.100.008 |
| 2 | 100 | 7,5 | 32 | 8 | 8974.100.108 |
| 1+2 | | | | | 8974.001.000 |
| Profil 2 • Profile 2 | | | | | |
| 1 | 120 | 15 | 32 | 6 | 8974.120.015 |
| 2 | 120 | 15 | 32 | 6 | 8974.120.115 |
| 1+2 | | | | | 8974.002.000 |
| Profil 3 • Profile 3 | | | | | |
| 1 | 120 | 15 | 32 | 6 | 8974.120.215 |
| 2 | 120 | 15 | 32 | 6 | 8974.120.315 |
| 1+2 | | | | | 8974.003.000 |

- HW-Profilmesserkopf mit Stahltragkörper zum Fräsen von Profil und Konterprofil an Aluminium-Profilen.
- Drei verschiedene Profilvarianten.
- Ausführungen für mechanischen Vorschub.
- *TC-Profile tipped cutterhead with steel tool body for profiles and counter profiles in aluminium-profiles.*
- *Three profile tool sets.*
- *Layout for mechanical feed.*

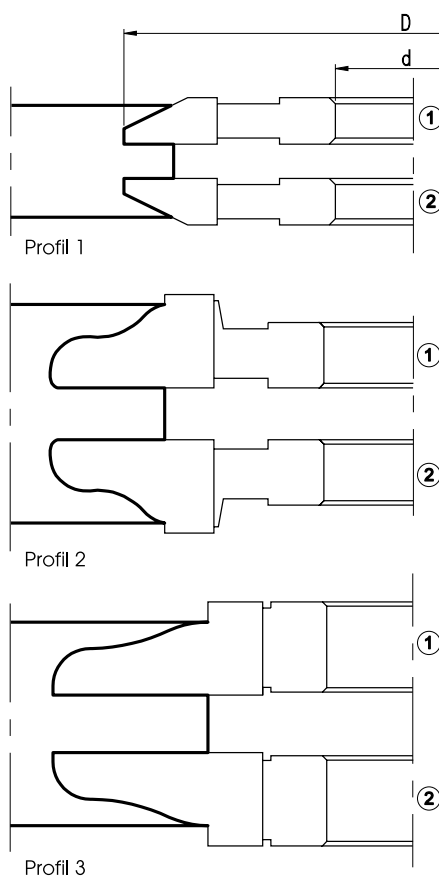



Verputzfräser (auf Anfrage)

Zum Überfräsen der verschweißten Gehrungsprofile

Deburring cutters (under request)

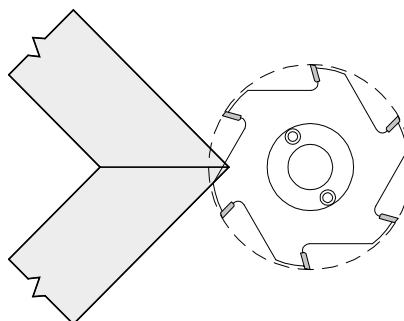
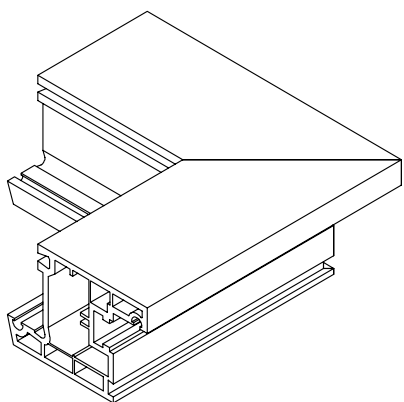
To clear welding excess on PVC windows and frames.
 Profiles compensated at 45° and set up to each job.

Profil-Konterprofilfräser (auf Anfrage)

Zum Fräsen von PVC-Profilen

Counterprofile cutters (under request)

For milling counter profiles a 90°.

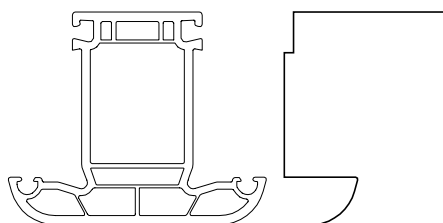
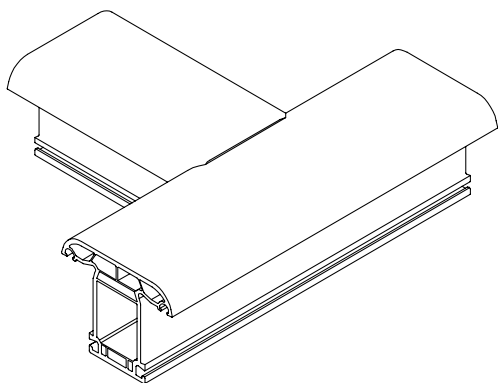



01



02



03



04



05



06



07



08



09



10



11



